

Visualization of Graphs

Lecture 1: Drawing Trees

Part I: Layered Drawings

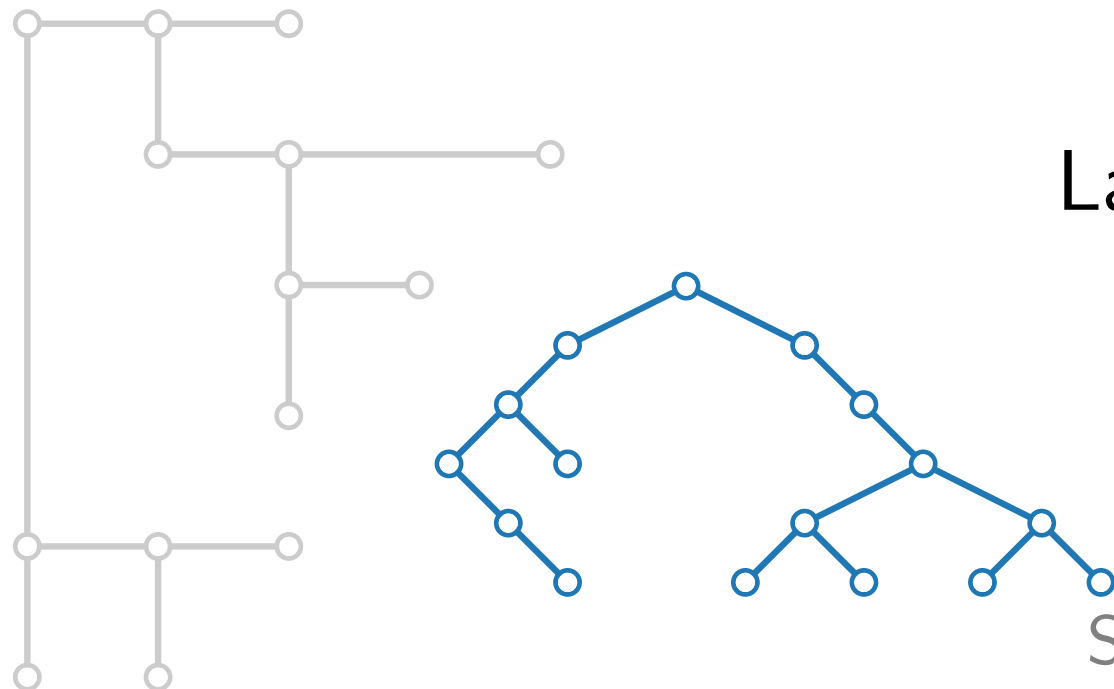

Alexander Wolff

Summer term 2025

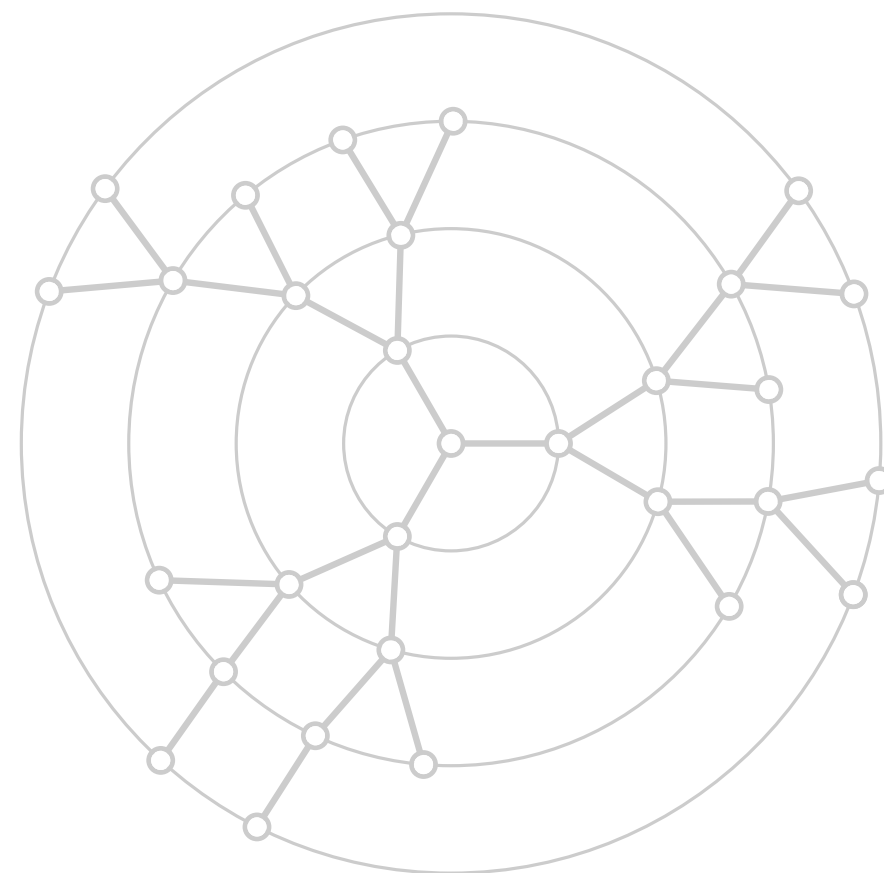

(Rooted) Trees

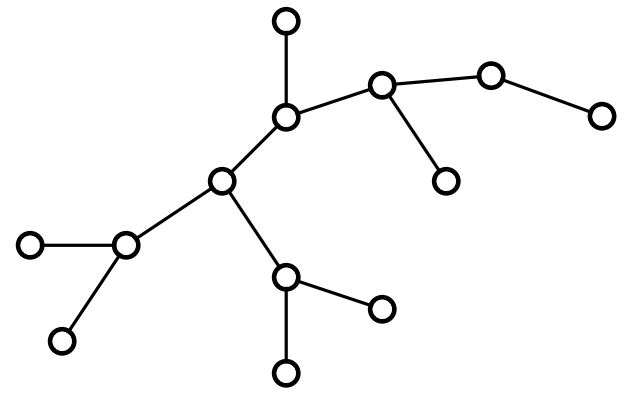

(Rooted) Trees

Leaf: vertex of degree 1

Rooted tree: tree with a designated **root**

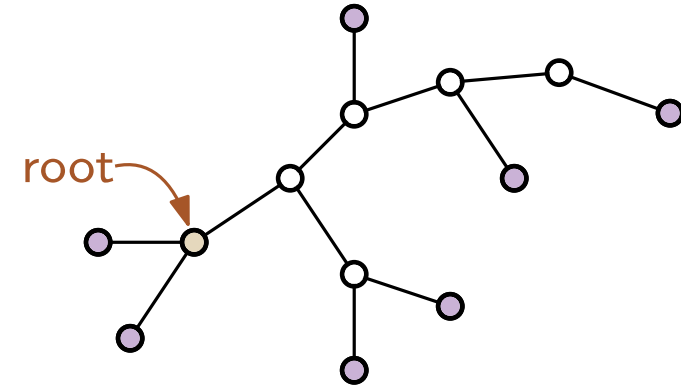

(Rooted) Trees

Leaf: vertex of degree 1

Rooted tree: tree with a designated **root**

Ancestor: vertex on the path to the root

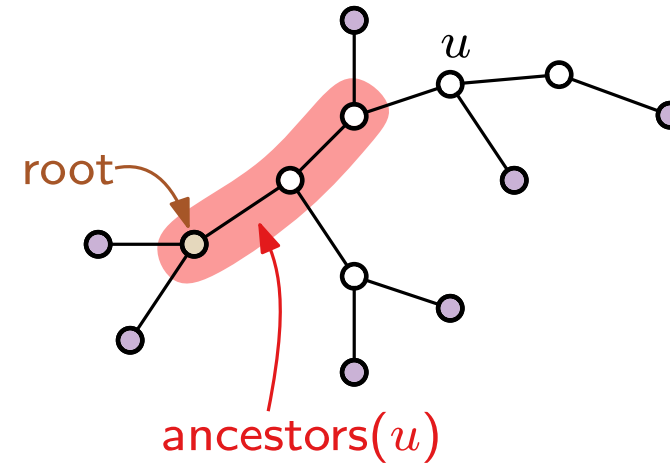

(Rooted) Trees

Leaf: vertex of degree 1

Rooted tree: tree with a designated **root**

Ancestor: vertex on the path to the root

Parent: neighbor on the path to the root

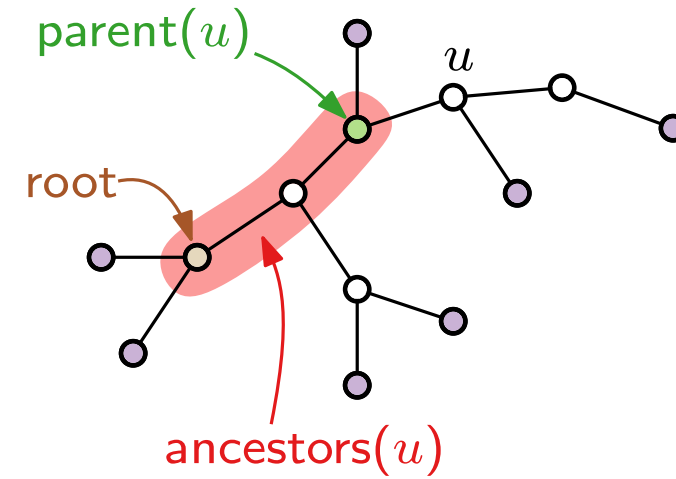

(Rooted) Trees

Leaf: vertex of degree 1

Rooted tree: tree with a designated **root**

Ancestor: vertex on the path to the root

Parent: neighbor on the path to the root

Successor: vertex on the path away from the root

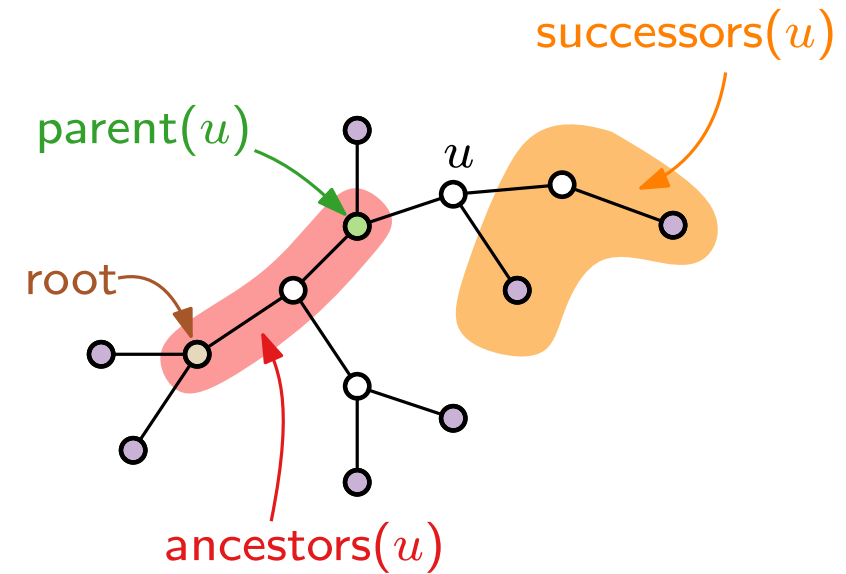

(Rooted) Trees

Leaf: vertex of degree 1

Rooted tree: tree with a designated **root**

Ancestor: vertex on the path to the root

Parent: neighbor on the path to the root

Successor: vertex on the path away from the root

Child: neighbor not on the path to the root

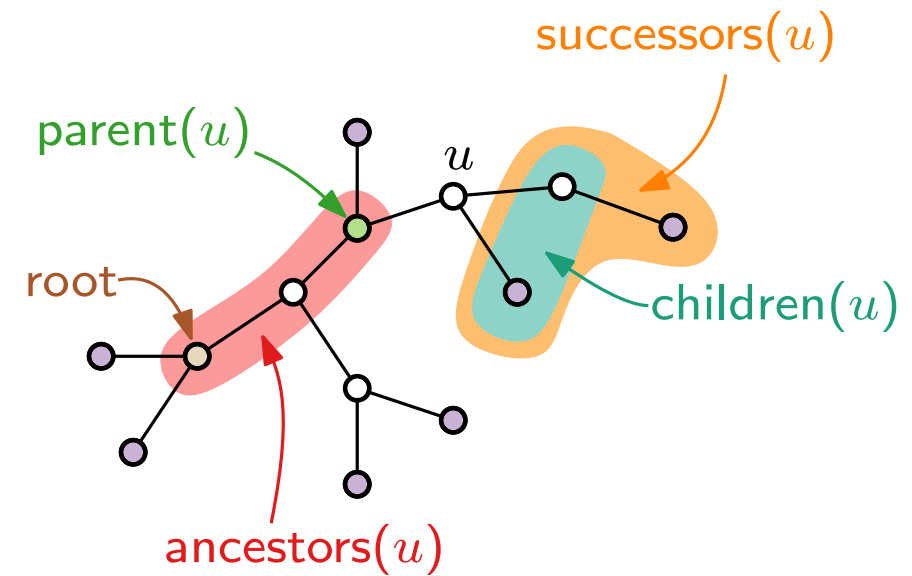

(Rooted) Trees

Leaf: vertex of degree 1

Rooted tree: tree with a designated **root**

Ancestor: vertex on the path to the root

Parent: neighbor on the path to the root

Successor: vertex on the path away from the root

Child: neighbor not on the path to the root

Depth: length of the path to the root

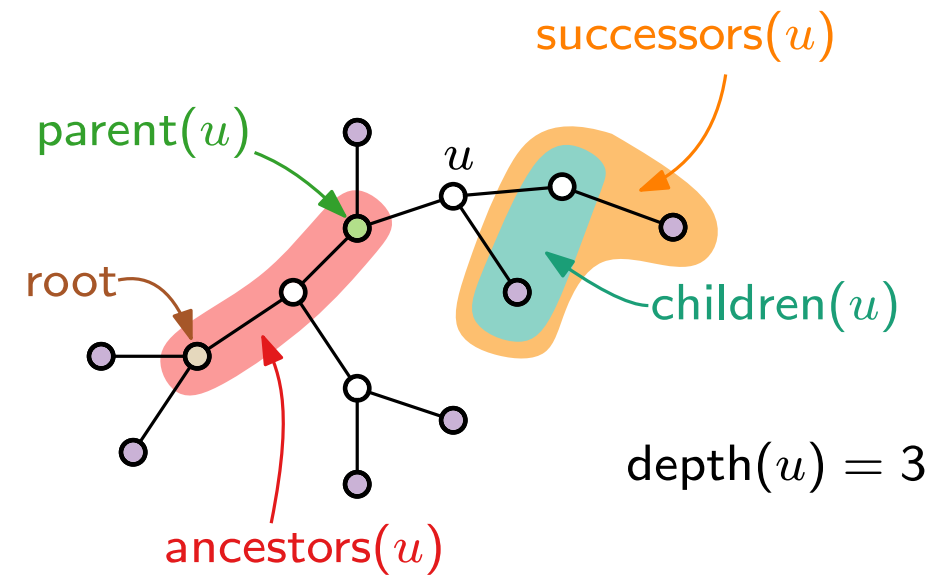

(Rooted) Trees

Leaf: vertex of degree 1

Rooted tree: tree with a designated **root**

Ancestor: vertex on the path to the root

Parent: neighbor on the path to the root

Successor: vertex on the path away from the root

Child: neighbor not on the path to the root

Depth: length of the path to the root

Height: maximum depth of a leaf

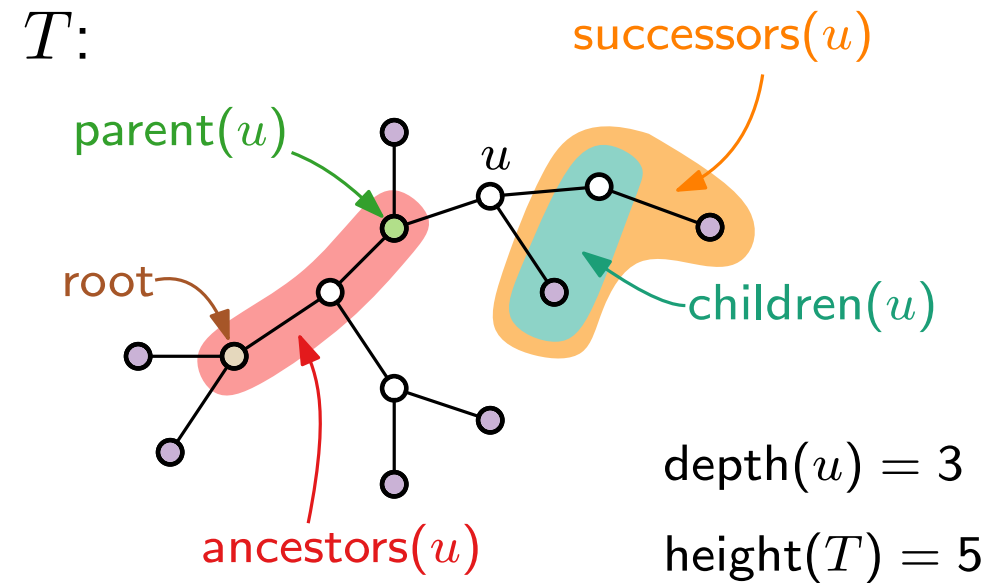

(Rooted) Trees

Leaf: vertex of degree 1

Rooted tree: tree with a designated **root**

Ancestor: vertex on the path to the root

Parent: neighbor on the path to the root

Successor: vertex on the path away from the root

Child: neighbor not on the path to the root

Depth: length of the path to the root

Height: maximum depth of a leaf

Binary Tree: at most two children per vertex (*left* and *right* child)

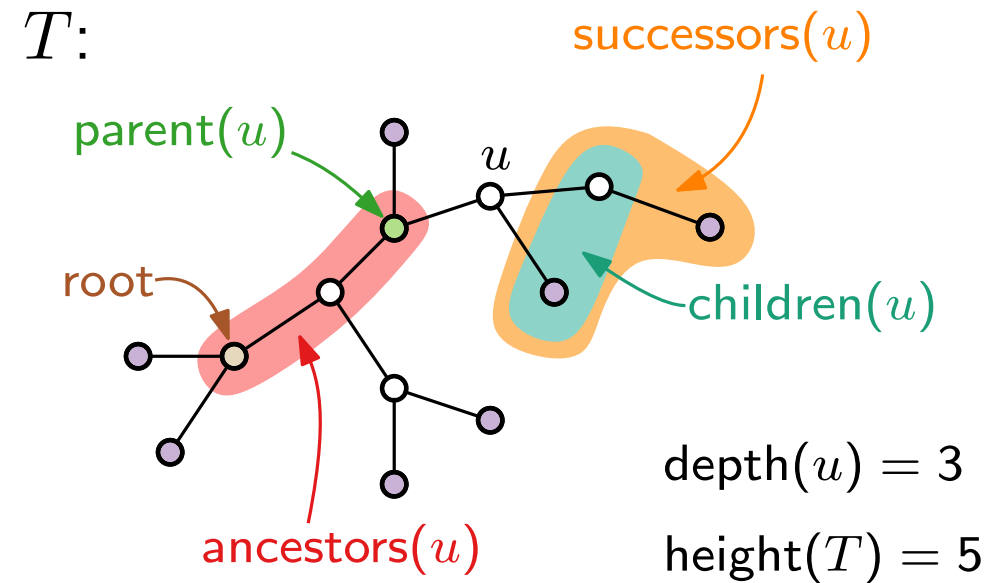

(Rooted) Trees

Leaf: vertex of degree 1

Rooted tree: tree with a designated **root**

Ancestor: vertex on the path to the root

Parent: neighbor on the path to the root

Successor: vertex on the path away from the root

Child: neighbor not on the path to the root

Depth: length of the path to the root

Height: maximum depth of a leaf

Binary Tree: at most two children per vertex (*left* and *right* child)

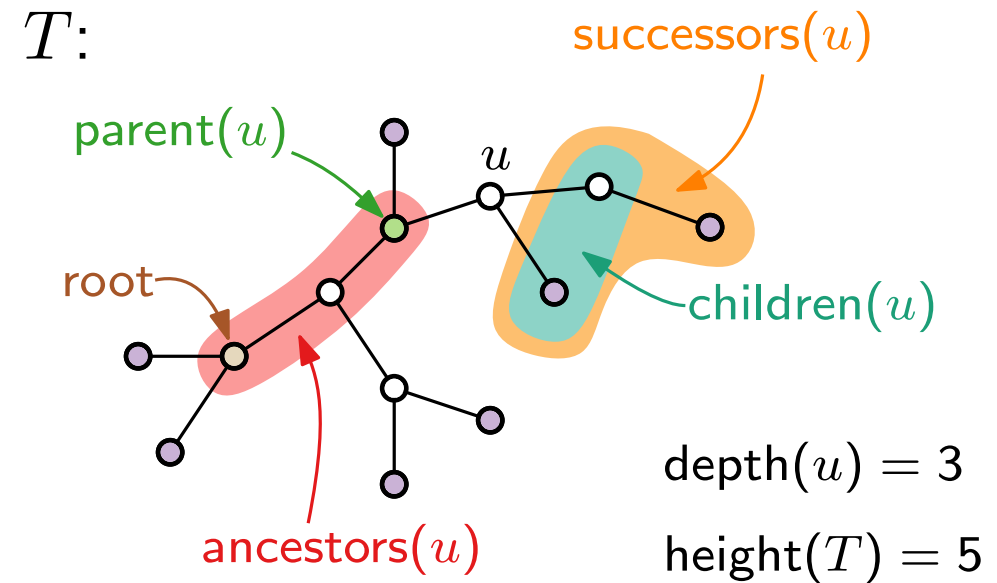
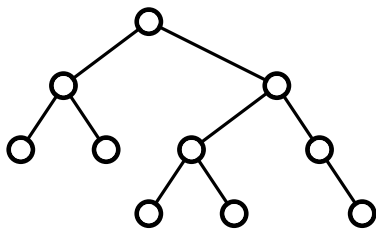

(Rooted) Trees

Leaf: vertex of degree 1

Rooted tree: tree with a designated **root**

Ancestor: vertex on the path to the root

Parent: neighbor on the path to the root

Successor: vertex on the path away from the root

Child: neighbor not on the path to the root

Depth: length of the path to the root

Height: maximum depth of a leaf

Binary Tree: at most two children per vertex (*left* and *right* child)

3 types of tree traversals:

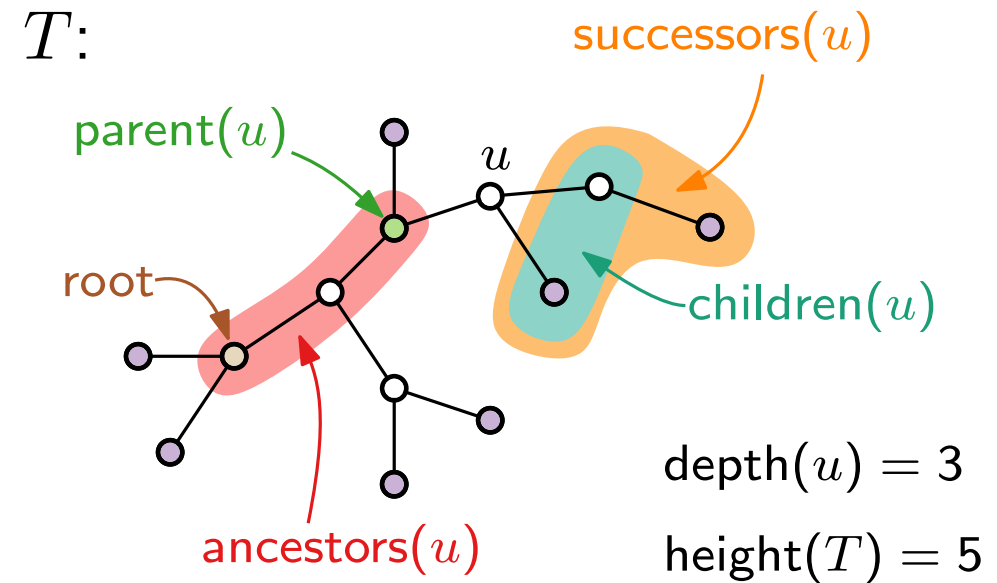
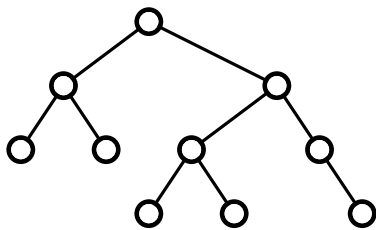

(Rooted) Trees

Leaf: vertex of degree 1

Rooted tree: tree with a designated **root**

Ancestor: vertex on the path to the root

Parent: neighbor on the path to the root

Successor: vertex on the path away from the root

Child: neighbor not on the path to the root

Depth: length of the path to the root

Height: maximum depth of a leaf

Binary Tree: at most two children per vertex (*left* and *right* child)

3 types of tree traversals:

preorder

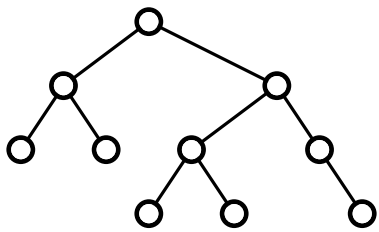

node – left – right

T :

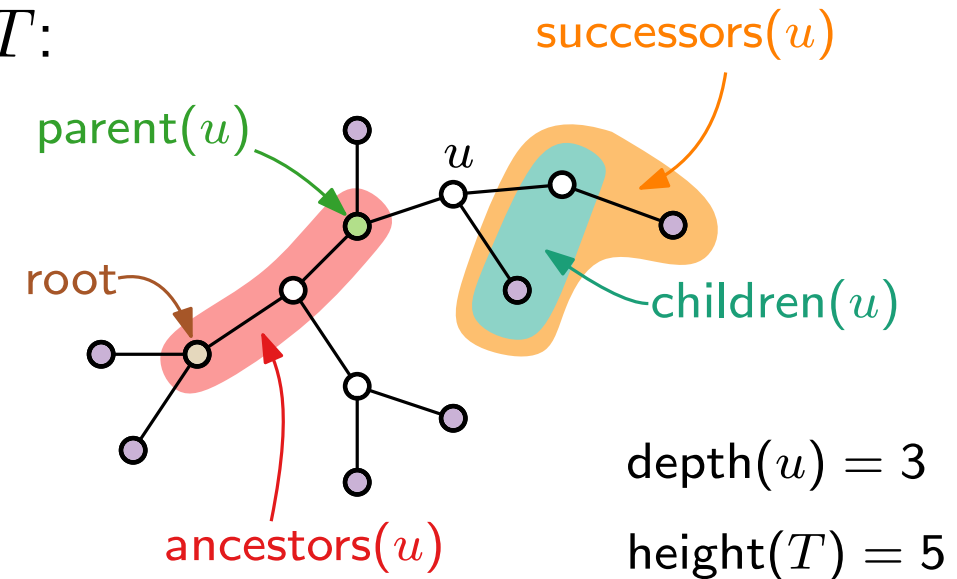

(Rooted) Trees

Leaf: vertex of degree 1

Rooted tree: tree with a designated **root**

Ancestor: vertex on the path to the root

Parent: neighbor on the path to the root

Successor: vertex on the path away from the root

Child: neighbor not on the path to the root

Depth: length of the path to the root

Height: maximum depth of a leaf

Binary Tree: at most two children per vertex (*left* and *right* child)

3 types of tree traversals:

preorder

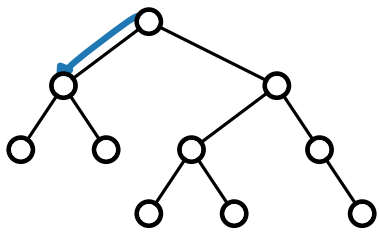

node – left – right

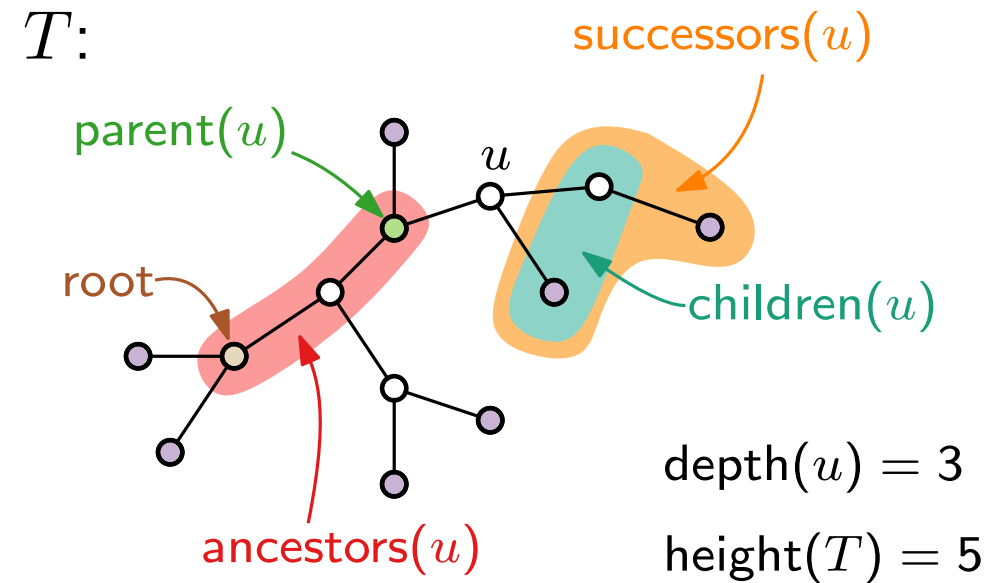

(Rooted) Trees

Leaf: vertex of degree 1

Rooted tree: tree with a designated **root**

Ancestor: vertex on the path to the root

Parent: neighbor on the path to the root

Successor: vertex on the path away from the root

Child: neighbor not on the path to the root

Depth: length of the path to the root

Height: maximum depth of a leaf

Binary Tree: at most two children per vertex (*left* and *right* child)

3 types of tree traversals:

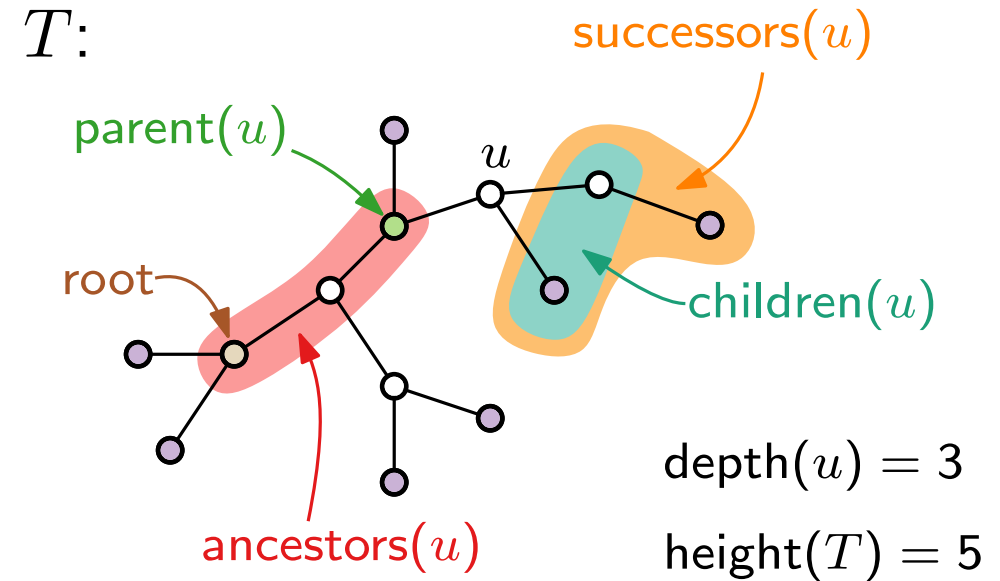
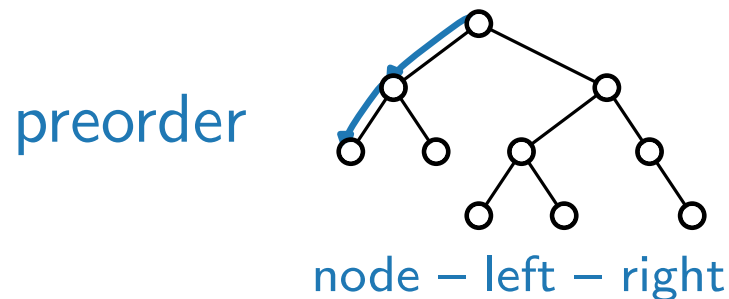

(Rooted) Trees

Leaf: vertex of degree 1

Rooted tree: tree with a designated **root**

Ancestor: vertex on the path to the root

Parent: neighbor on the path to the root

Successor: vertex on the path away from the root

Child: neighbor not on the path to the root

Depth: length of the path to the root

Height: maximum depth of a leaf

Binary Tree: at most two children per vertex (*left* and *right* child)

3 types of tree traversals:

preorder

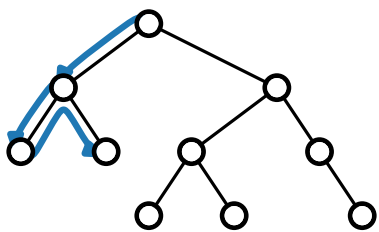

node – left – right

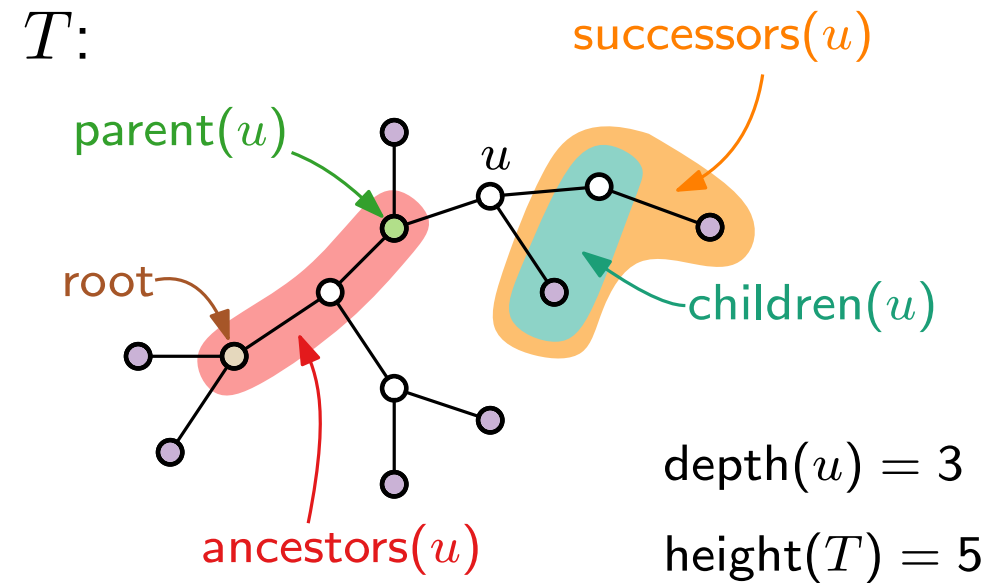

(Rooted) Trees

Leaf: vertex of degree 1

Rooted tree: tree with a designated **root**

Ancestor: vertex on the path to the root

Parent: neighbor on the path to the root

Successor: vertex on the path away from the root

Child: neighbor not on the path to the root

Depth: length of the path to the root

Height: maximum depth of a leaf

Binary Tree: at most two children per vertex (*left* and *right* child)

3 types of tree traversals:

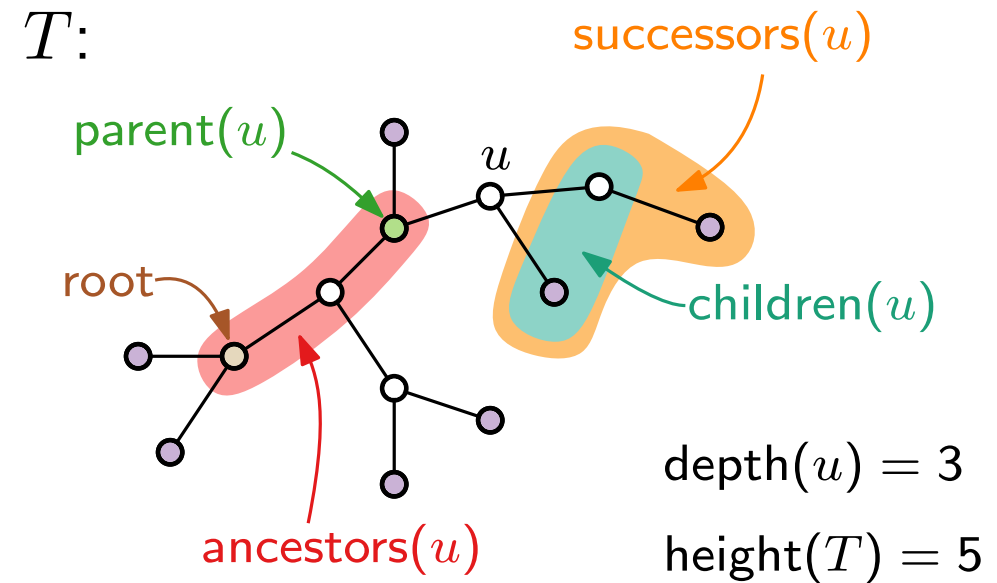
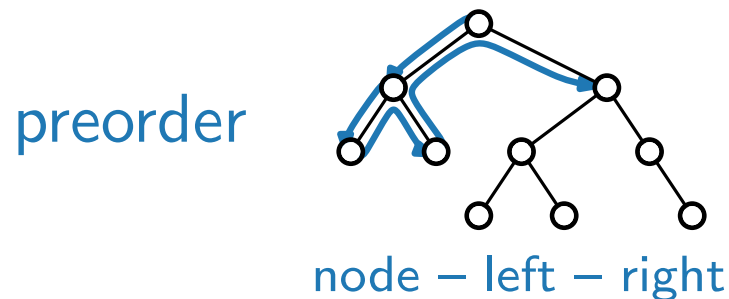

(Rooted) Trees

Leaf: vertex of degree 1

Rooted tree: tree with a designated **root**

Ancestor: vertex on the path to the root

Parent: neighbor on the path to the root

Successor: vertex on the path away from the root

Child: neighbor not on the path to the root

Depth: length of the path to the root

Height: maximum depth of a leaf

Binary Tree: at most two children per vertex (*left* and *right* child)

3 types of tree traversals:

preorder

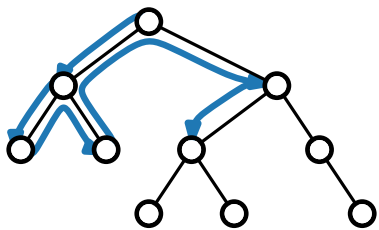

node – left – right

T :

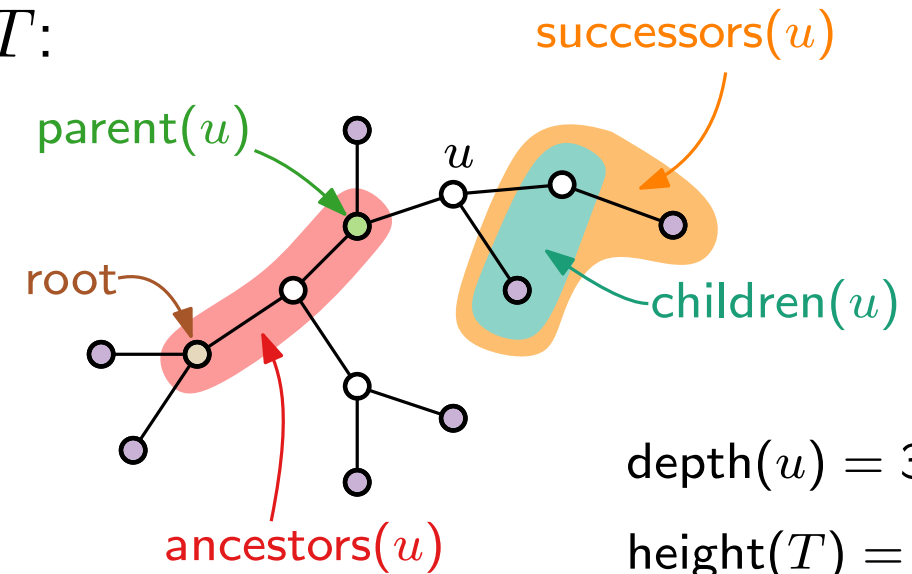

(Rooted) Trees

Leaf: vertex of degree 1

Rooted tree: tree with a designated **root**

Ancestor: vertex on the path to the root

Parent: neighbor on the path to the root

Successor: vertex on the path away from the root

Child: neighbor not on the path to the root

Depth: length of the path to the root

Height: maximum depth of a leaf

Binary Tree: at most two children per vertex (*left* and *right* child)

3 types of tree traversals:

preorder

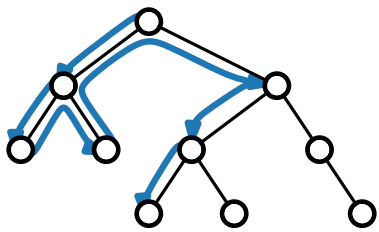

node – left – right

T :

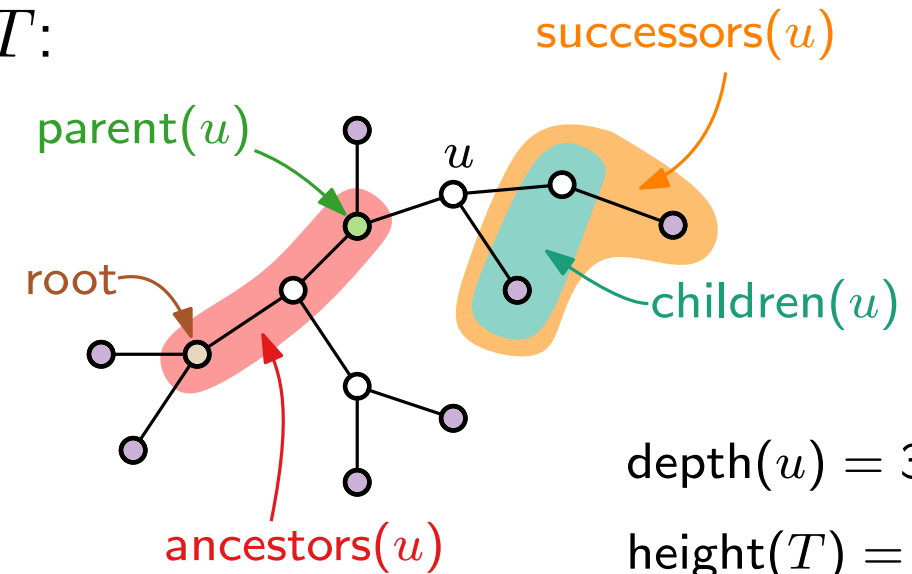

(Rooted) Trees

Leaf: vertex of degree 1

Rooted tree: tree with a designated **root**

Ancestor: vertex on the path to the root

Parent: neighbor on the path to the root

Successor: vertex on the path away from the root

Child: neighbor not on the path to the root

Depth: length of the path to the root

Height: maximum depth of a leaf

Binary Tree: at most two children per vertex (*left* and *right* child)

3 types of tree traversals:

preorder

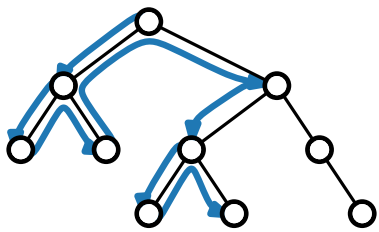

node – left – right

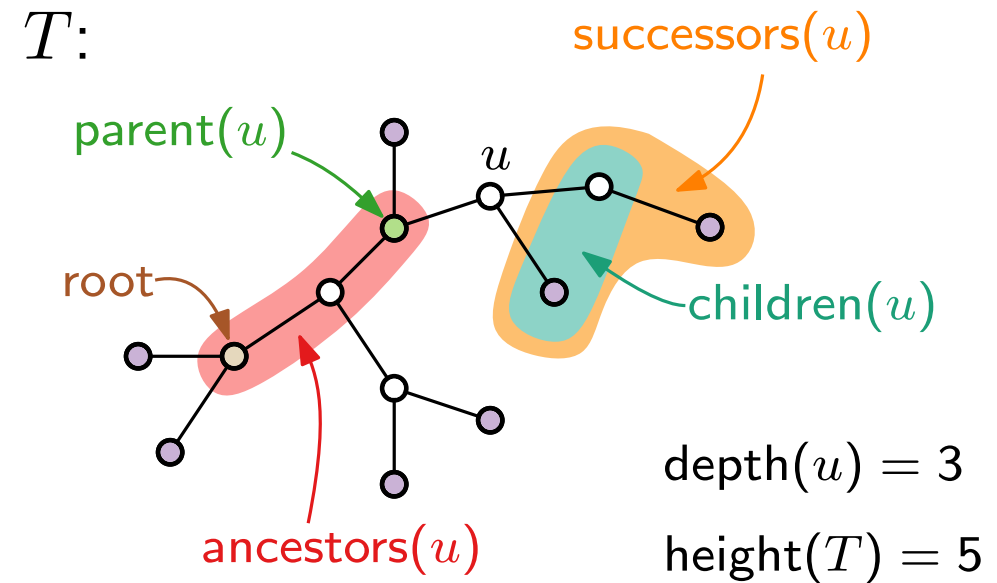

(Rooted) Trees

Leaf: vertex of degree 1

Rooted tree: tree with a designated **root**

Ancestor: vertex on the path to the root

Parent: neighbor on the path to the root

Successor: vertex on the path away from the root

Child: neighbor not on the path to the root

Depth: length of the path to the root

Height: maximum depth of a leaf

Binary Tree: at most two children per vertex (*left* and *right* child)

3 types of tree traversals:

preorder

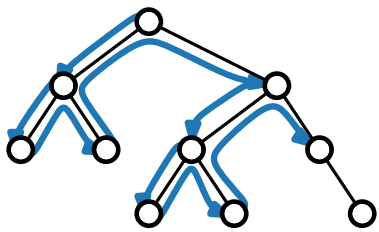

node – left – right

T :

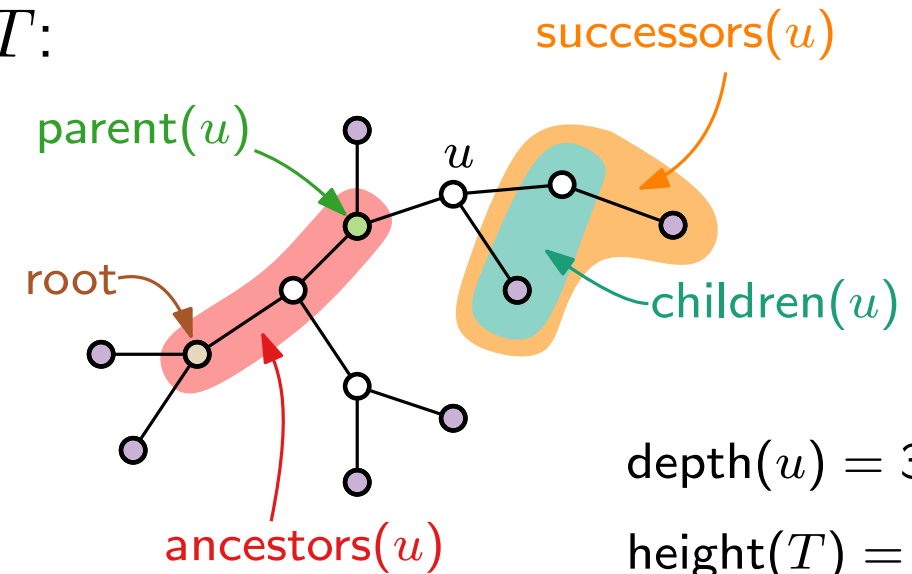

(Rooted) Trees

Leaf: vertex of degree 1

Rooted tree: tree with a designated **root**

Ancestor: vertex on the path to the root

Parent: neighbor on the path to the root

Successor: vertex on the path away from the root

Child: neighbor not on the path to the root

Depth: length of the path to the root

Height: maximum depth of a leaf

Binary Tree: at most two children per vertex (*left* and *right* child)

3 types of tree traversals:

preorder

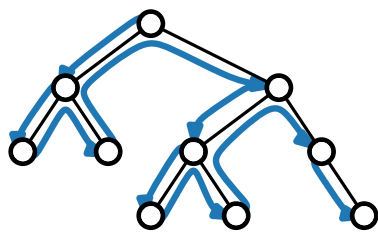

node – left – right

T :

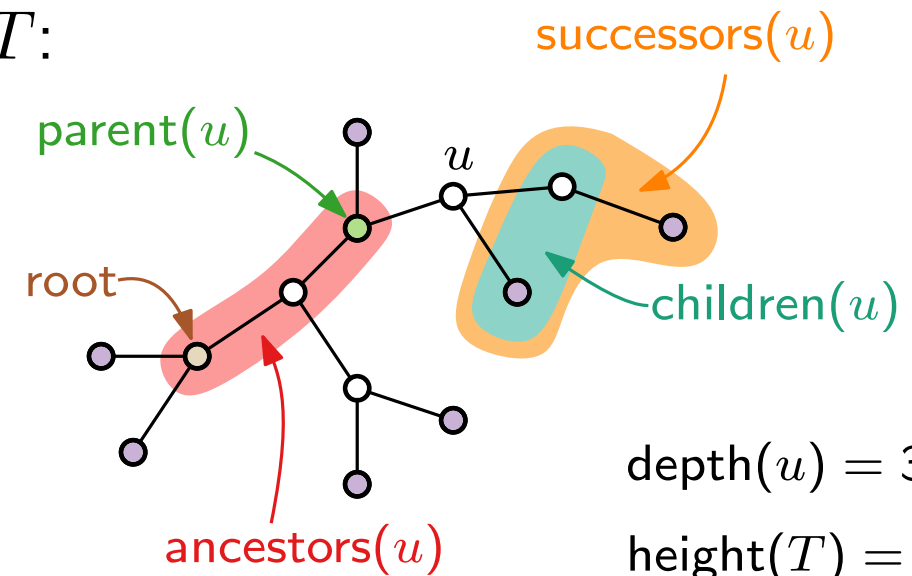

(Rooted) Trees

Leaf: vertex of degree 1

Rooted tree: tree with a designated **root**

Ancestor: vertex on the path to the root

Parent: neighbor on the path to the root

Successor: vertex on the path away from the root

Child: neighbor not on the path to the root

Depth: length of the path to the root

Height: maximum depth of a leaf

Binary Tree: at most two children per vertex (*left* and *right* child)

3 types of tree traversals:

preorder

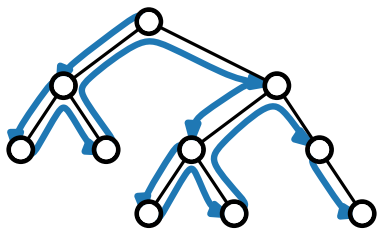

node – left – right

inorder

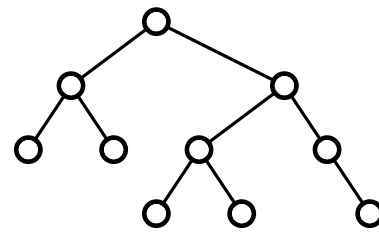

left – node – right

T :

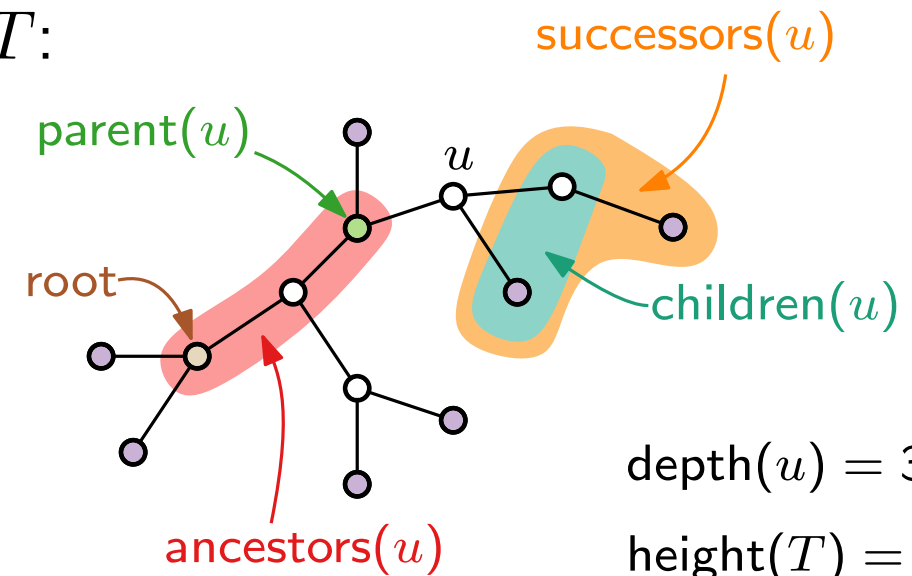

$\text{depth}(u) = 3$

$\text{height}(T) = 5$

(Rooted) Trees

Leaf: vertex of degree 1

Rooted tree: tree with a designated **root**

Ancestor: vertex on the path to the root

Parent: neighbor on the path to the root

Successor: vertex on the path away from the root

Child: neighbor not on the path to the root

Depth: length of the path to the root

Height: maximum depth of a leaf

Binary Tree: at most two children per vertex (*left* and *right* child)

3 types of tree traversals:

preorder

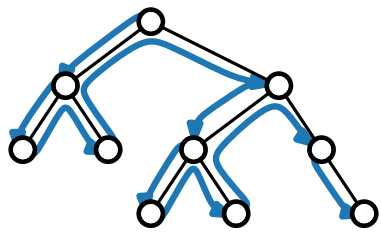

node – left – right

inorder

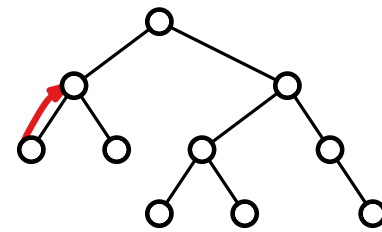

left – node – right

T :

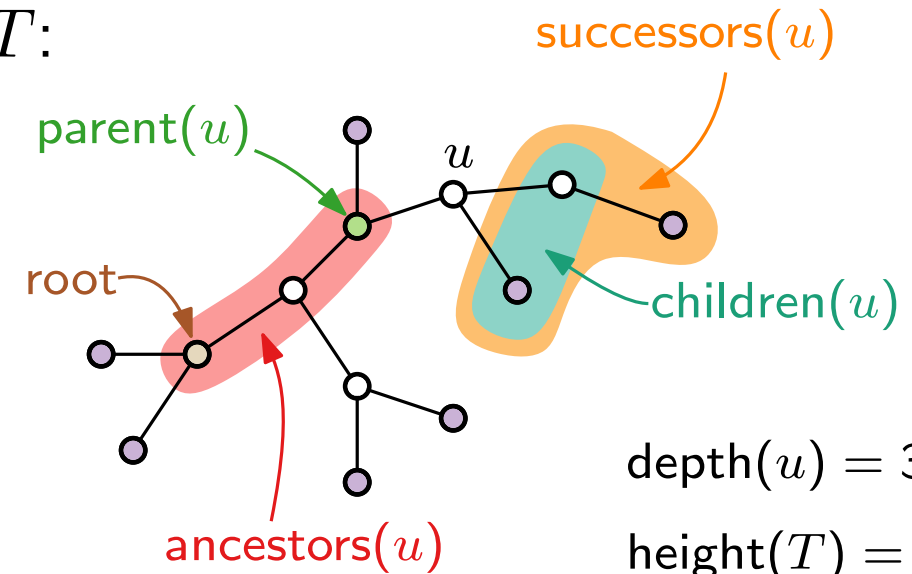

$\text{depth}(u) = 3$

$\text{height}(T) = 5$

(Rooted) Trees

Leaf: vertex of degree 1

Rooted tree: tree with a designated **root**

Ancestor: vertex on the path to the root

Parent: neighbor on the path to the root

Successor: vertex on the path away from the root

Child: neighbor not on the path to the root

Depth: length of the path to the root

Height: maximum depth of a leaf

Binary Tree: at most two children per vertex (*left* and *right* child)

3 types of tree traversals:

preorder

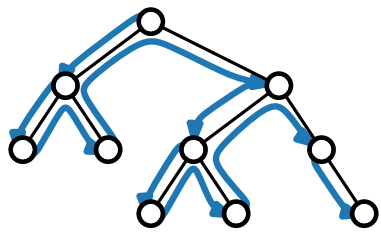

node – left – right

inorder

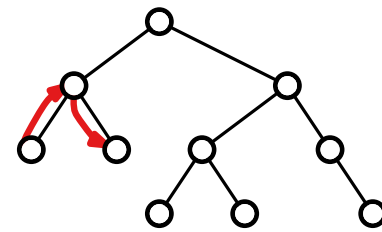

left – node – right

T :

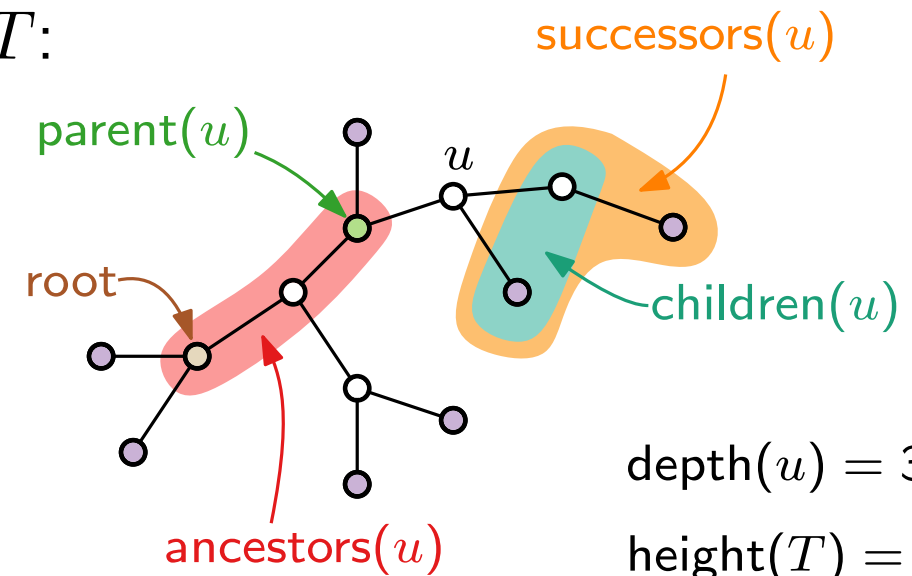

$\text{depth}(u) = 3$

$\text{height}(T) = 5$

(Rooted) Trees

Leaf: vertex of degree 1

Rooted tree: tree with a designated **root**

Ancestor: vertex on the path to the root

Parent: neighbor on the path to the root

Successor: vertex on the path away from the root

Child: neighbor not on the path to the root

Depth: length of the path to the root

Height: maximum depth of a leaf

Binary Tree: at most two children per vertex (*left* and *right* child)

3 types of tree traversals:

preorder

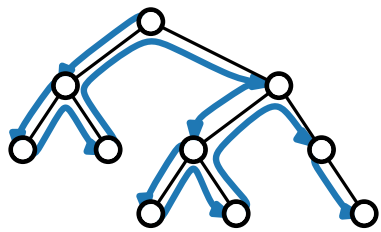

node – left – right

inorder

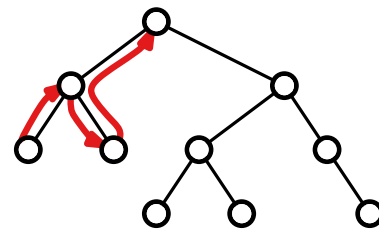

left – node – right

T :

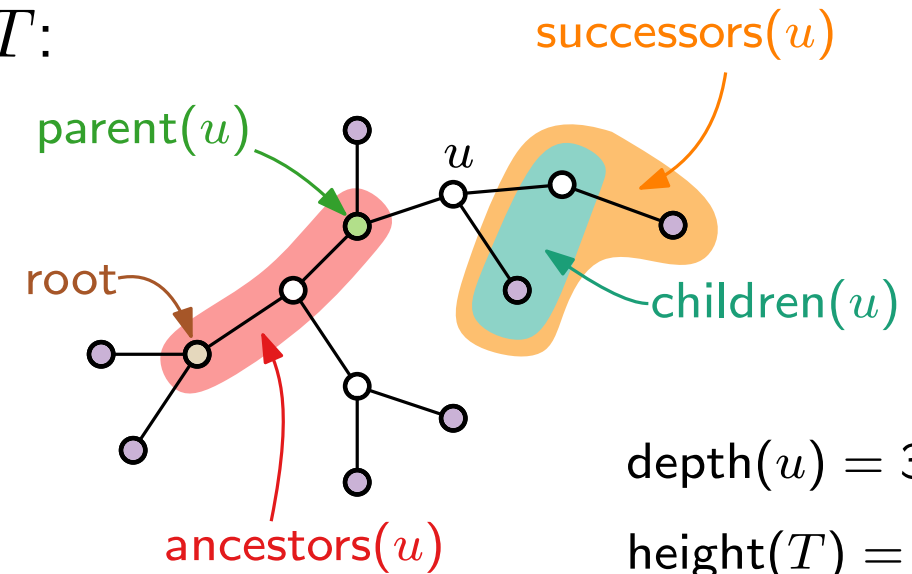

$\text{depth}(u) = 3$

$\text{height}(T) = 5$

(Rooted) Trees

Leaf: vertex of degree 1

Rooted tree: tree with a designated **root**

Ancestor: vertex on the path to the root

Parent: neighbor on the path to the root

Successor: vertex on the path away from the root

Child: neighbor not on the path to the root

Depth: length of the path to the root

Height: maximum depth of a leaf

Binary Tree: at most two children per vertex (*left* and *right* child)

3 types of tree traversals:

preorder

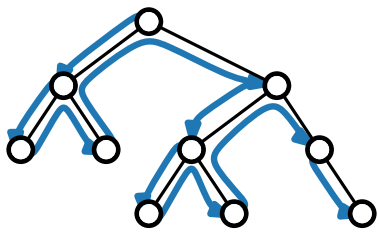

node - left - right

inorder

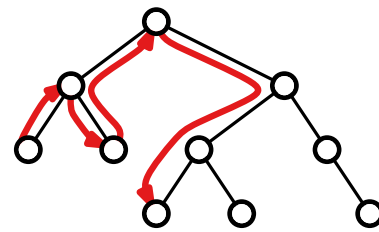

left - node - right

T :

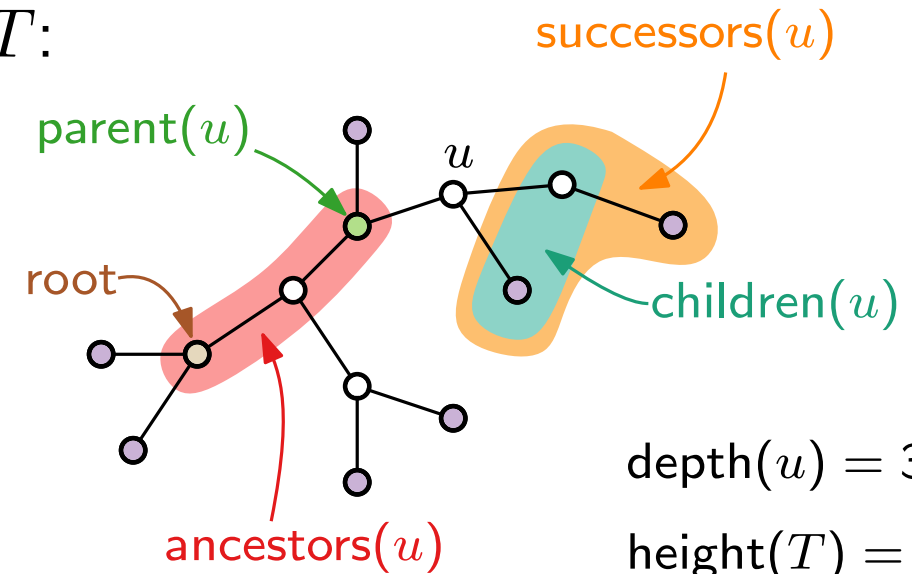

$\text{depth}(u) = 3$

$\text{height}(T) = 5$

(Rooted) Trees

Leaf: vertex of degree 1

Rooted tree: tree with a designated **root**

Ancestor: vertex on the path to the root

Parent: neighbor on the path to the root

Successor: vertex on the path away from the root

Child: neighbor not on the path to the root

Depth: length of the path to the root

Height: maximum depth of a leaf

Binary Tree: at most two children per vertex (*left* and *right* child)

3 types of tree traversals:

preorder

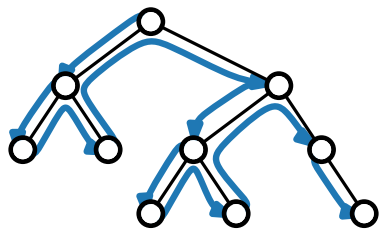

node – left – right

inorder

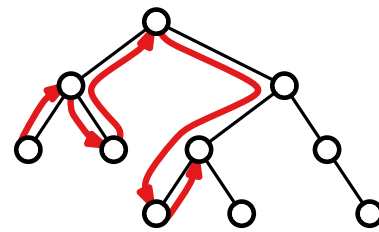

left – node – right

T :

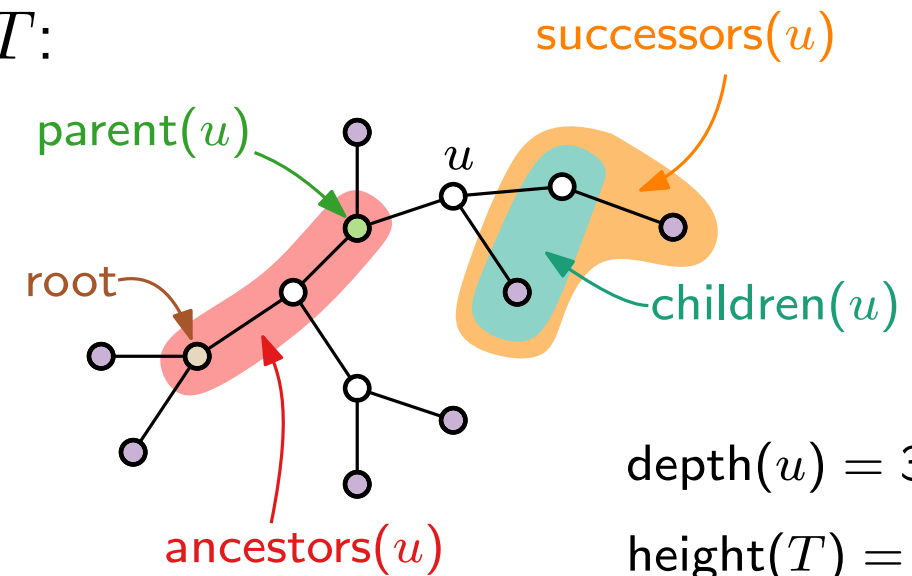

$\text{depth}(u) = 3$

$\text{height}(T) = 5$

(Rooted) Trees

Leaf: vertex of degree 1

Rooted tree: tree with a designated **root**

Ancestor: vertex on the path to the root

Parent: neighbor on the path to the root

Successor: vertex on the path away from the root

Child: neighbor not on the path to the root

Depth: length of the path to the root

Height: maximum depth of a leaf

Binary Tree: at most two children per vertex (*left* and *right* child)

3 types of tree traversals:

preorder

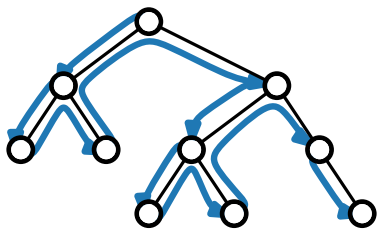

node - left - right

inorder

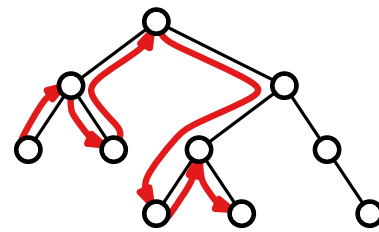

left - node - right

T :

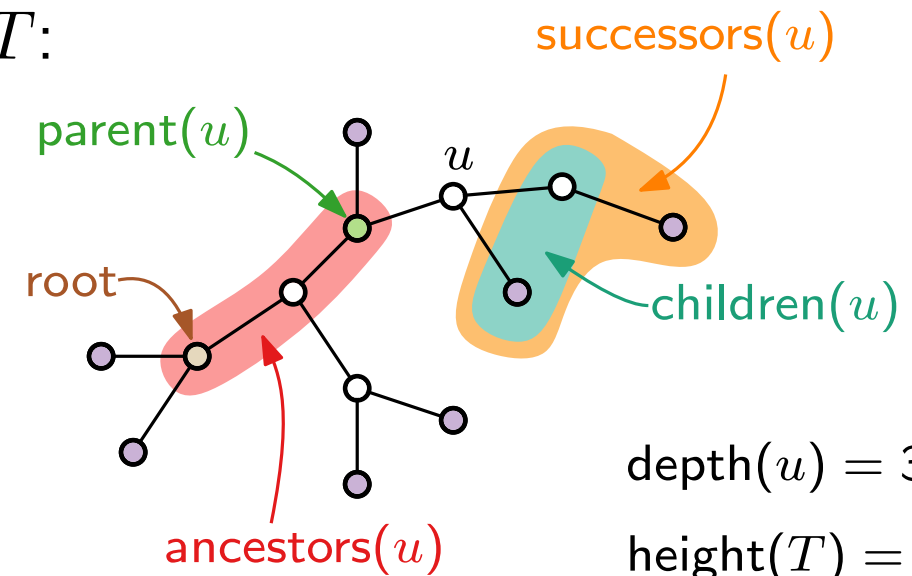

$\text{depth}(u) = 3$

$\text{height}(T) = 5$

(Rooted) Trees

Leaf: vertex of degree 1

Rooted tree: tree with a designated **root**

Ancestor: vertex on the path to the root

Parent: neighbor on the path to the root

Successor: vertex on the path away from the root

Child: neighbor not on the path to the root

Depth: length of the path to the root

Height: maximum depth of a leaf

Binary Tree: at most two children per vertex (*left* and *right* child)

3 types of tree traversals:

preorder

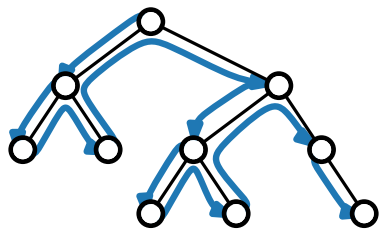

node – left – right

inorder

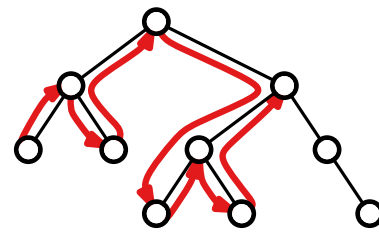

left – node – right

T :

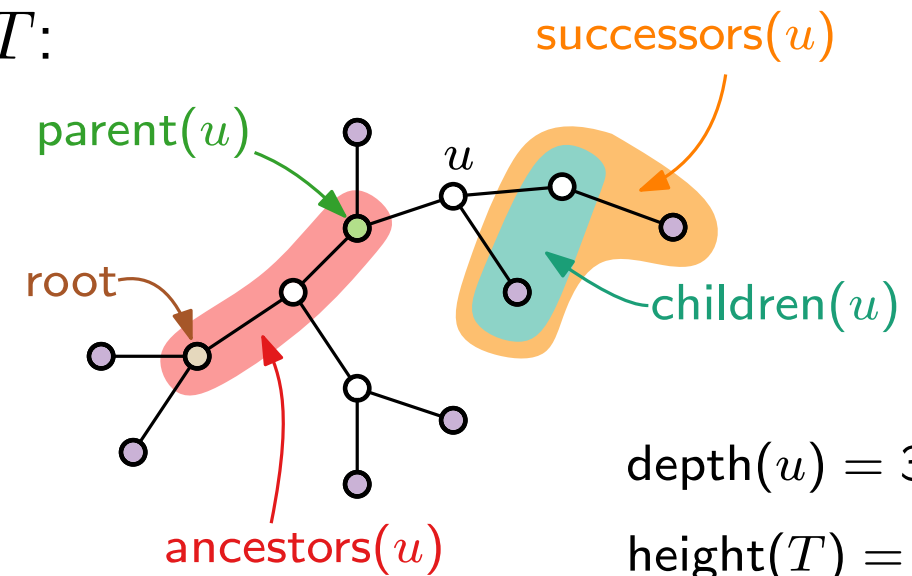

$\text{depth}(u) = 3$

$\text{height}(T) = 5$

(Rooted) Trees

Leaf: vertex of degree 1

Rooted tree: tree with a designated **root**

Ancestor: vertex on the path to the root

Parent: neighbor on the path to the root

Successor: vertex on the path away from the root

Child: neighbor not on the path to the root

Depth: length of the path to the root

Height: maximum depth of a leaf

Binary Tree: at most two children per vertex (*left* and *right* child)

3 types of tree traversals:

preorder

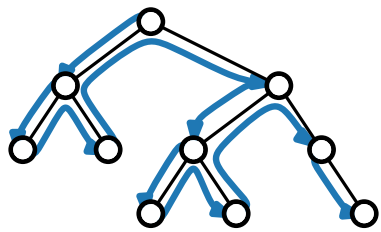

node – left – right

inorder

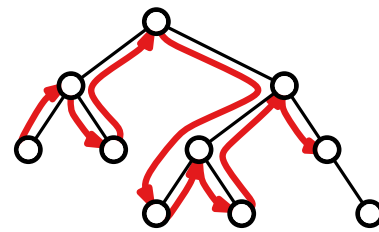

left – node – right

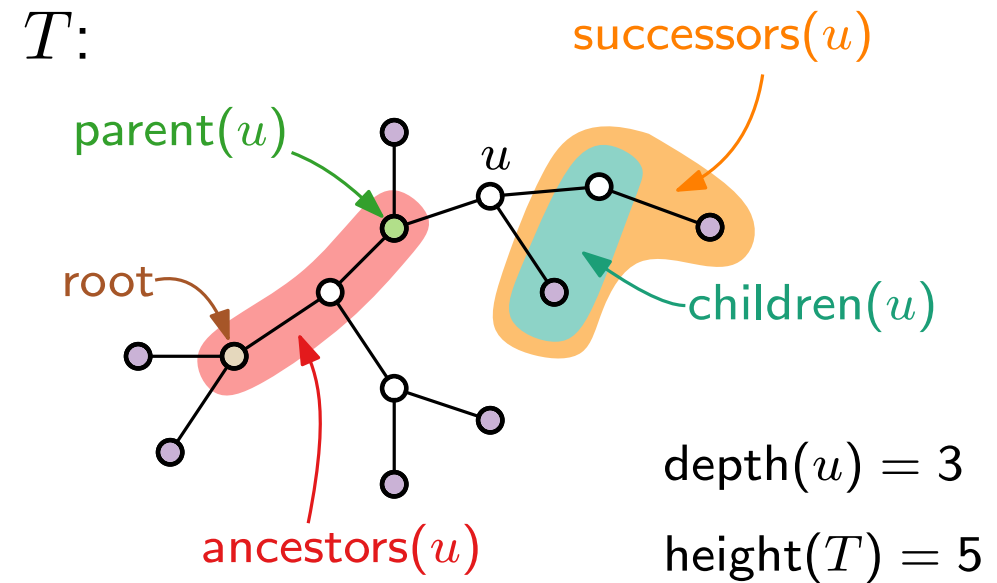

(Rooted) Trees

Leaf: vertex of degree 1

Rooted tree: tree with a designated **root**

Ancestor: vertex on the path to the root

Parent: neighbor on the path to the root

Successor: vertex on the path away from the root

Child: neighbor not on the path to the root

Depth: length of the path to the root

Height: maximum depth of a leaf

Binary Tree: at most two children per vertex (*left* and *right* child)

3 types of tree traversals:

preorder

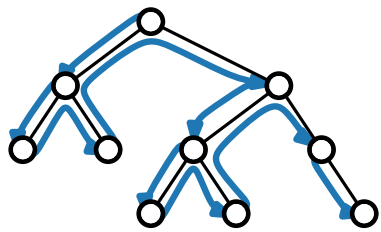

node – left – right

inorder

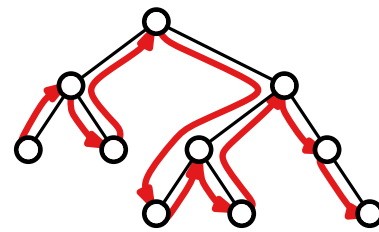

left – node – right

T :

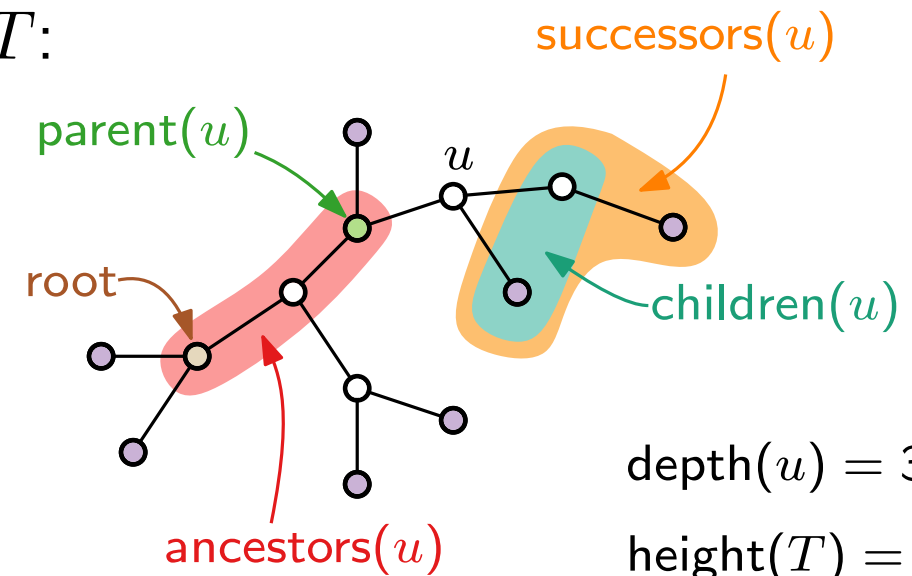

$\text{depth}(u) = 3$

$\text{height}(T) = 5$

(Rooted) Trees

Leaf: vertex of degree 1

Rooted tree: tree with a designated **root**

Ancestor: vertex on the path to the root

Parent: neighbor on the path to the root

Successor: vertex on the path away from the root

Child: neighbor not on the path to the root

Depth: length of the path to the root

Height: maximum depth of a leaf

Binary Tree: at most two children per vertex (*left* and *right* child)

3 types of tree traversals:

preorder

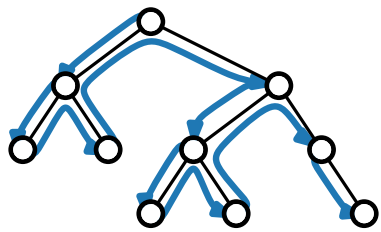

node - left - right

inorder

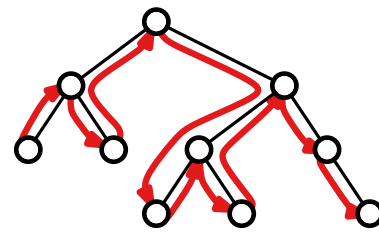

left - node - right

postorder

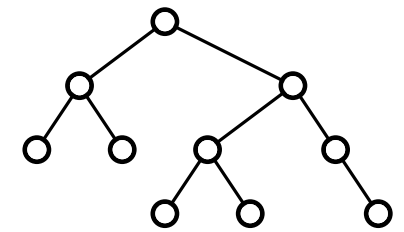

left - right - node

T :

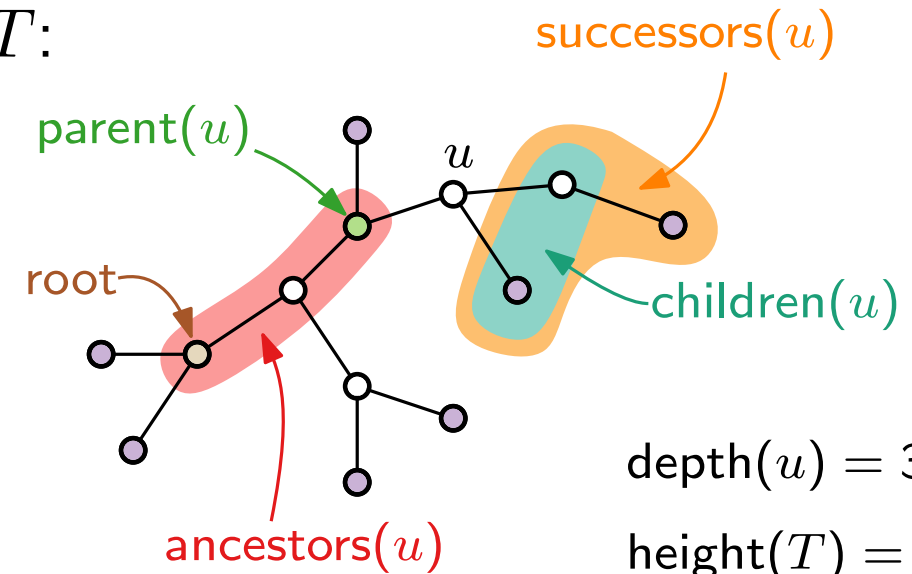

$\text{depth}(u) = 3$

$\text{height}(T) = 5$

(Rooted) Trees

Leaf: vertex of degree 1

Rooted tree: tree with a designated **root**

Ancestor: vertex on the path to the root

Parent: neighbor on the path to the root

Successor: vertex on the path away from the root

Child: neighbor not on the path to the root

Depth: length of the path to the root

Height: maximum depth of a leaf

Binary Tree: at most two children per vertex (*left* and *right* child)

3 types of tree traversals:

preorder

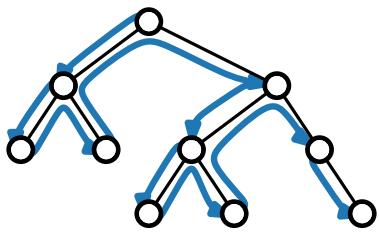

node - left - right

inorder

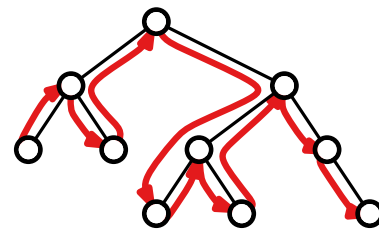

left - node - right

postorder

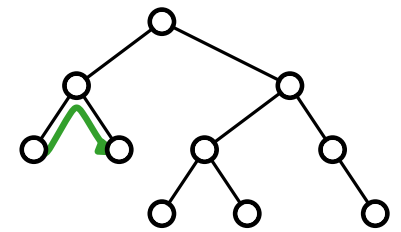

left - right - node

T :

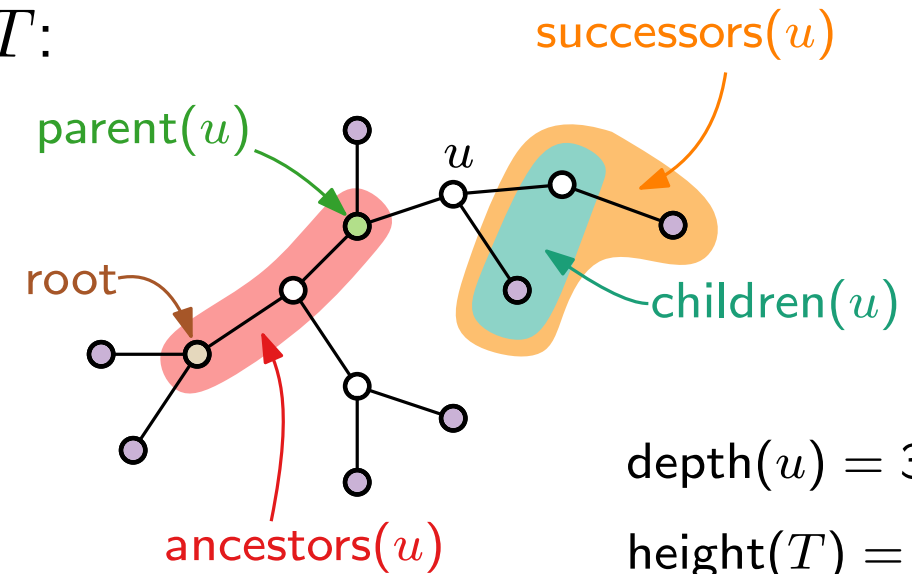

$\text{depth}(u) = 3$

$\text{height}(T) = 5$

(Rooted) Trees

Leaf: vertex of degree 1

Rooted tree: tree with a designated **root**

Ancestor: vertex on the path to the root

Parent: neighbor on the path to the root

Successor: vertex on the path away from the root

Child: neighbor not on the path to the root

Depth: length of the path to the root

Height: maximum depth of a leaf

Binary Tree: at most two children per vertex (*left* and *right* child)

3 types of tree traversals:

preorder

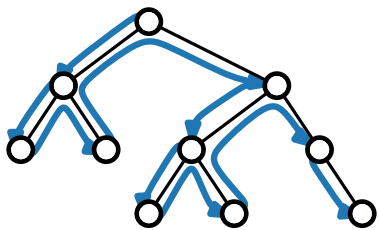

node – left – right

inorder

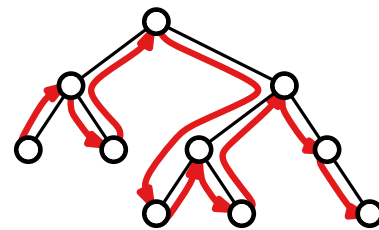

left – node – right

postorder

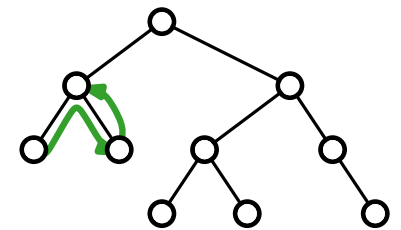

left – right – node

T :

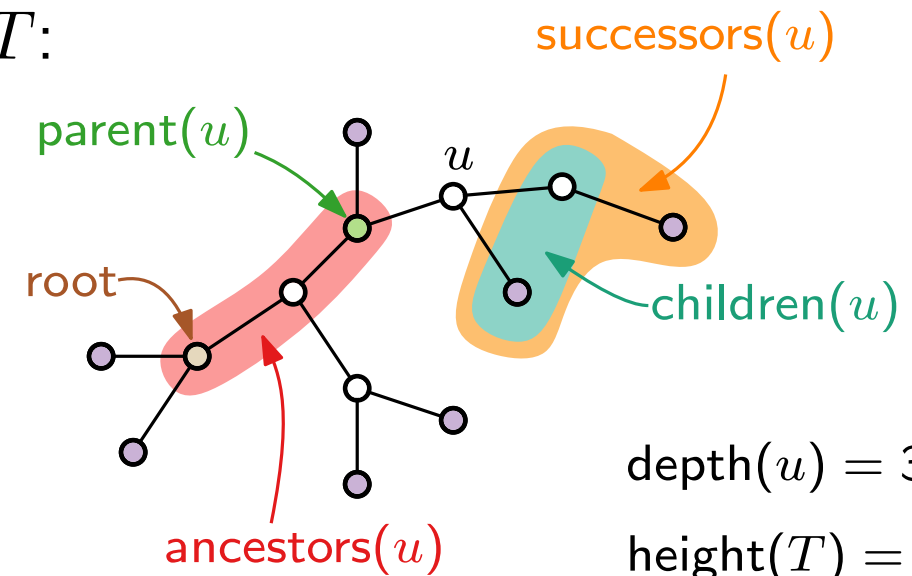

$\text{depth}(u) = 3$

$\text{height}(T) = 5$

(Rooted) Trees

Leaf: vertex of degree 1

Rooted tree: tree with a designated **root**

Ancestor: vertex on the path to the root

Parent: neighbor on the path to the root

Successor: vertex on the path away from the root

Child: neighbor not on the path to the root

Depth: length of the path to the root

Height: maximum depth of a leaf

Binary Tree: at most two children per vertex (*left* and *right* child)

3 types of tree traversals:

preorder

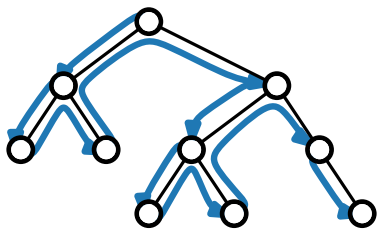

node – left – right

inorder

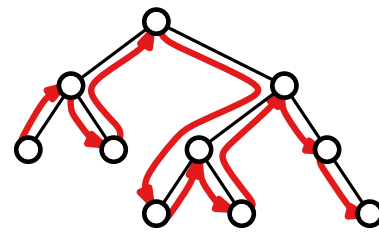

left – node – right

postorder

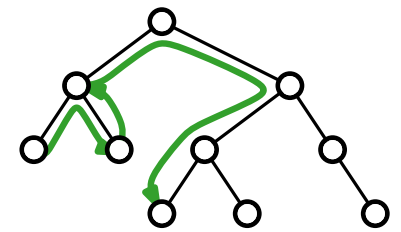

left – right – node

T :

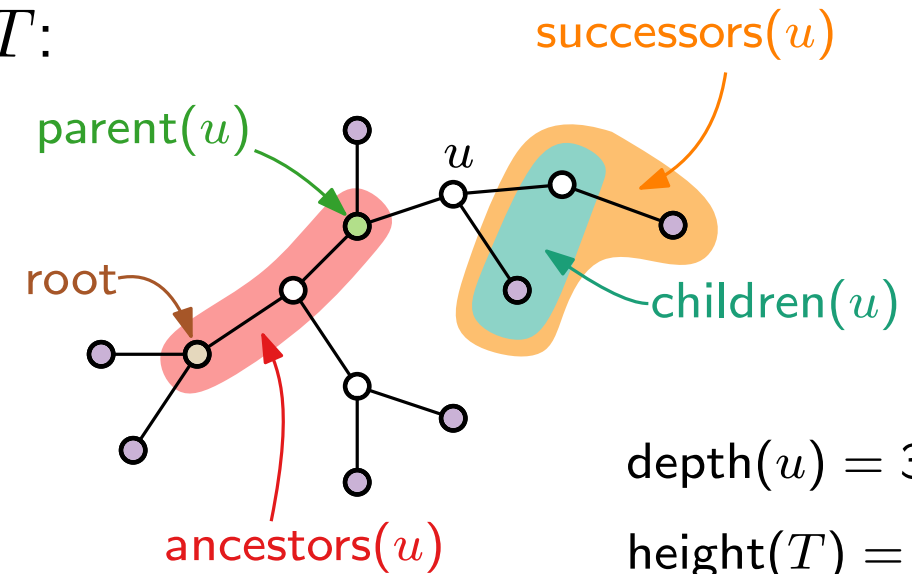

$\text{depth}(u) = 3$

$\text{height}(T) = 5$

(Rooted) Trees

Leaf: vertex of degree 1

Rooted tree: tree with a designated **root**

Ancestor: vertex on the path to the root

Parent: neighbor on the path to the root

Successor: vertex on the path away from the root

Child: neighbor not on the path to the root

Depth: length of the path to the root

Height: maximum depth of a leaf

Binary Tree: at most two children per vertex (*left* and *right* child)

3 types of tree traversals:

preorder

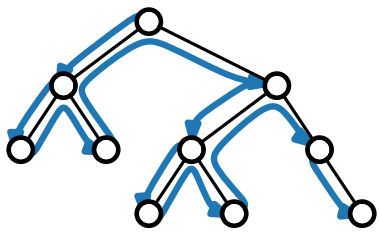

node – left – right

inorder

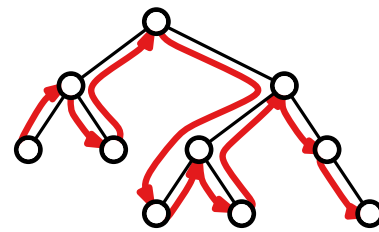

left – node – right

postorder

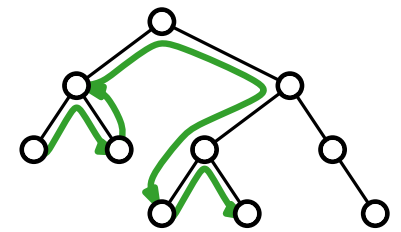

left – right – node

T :

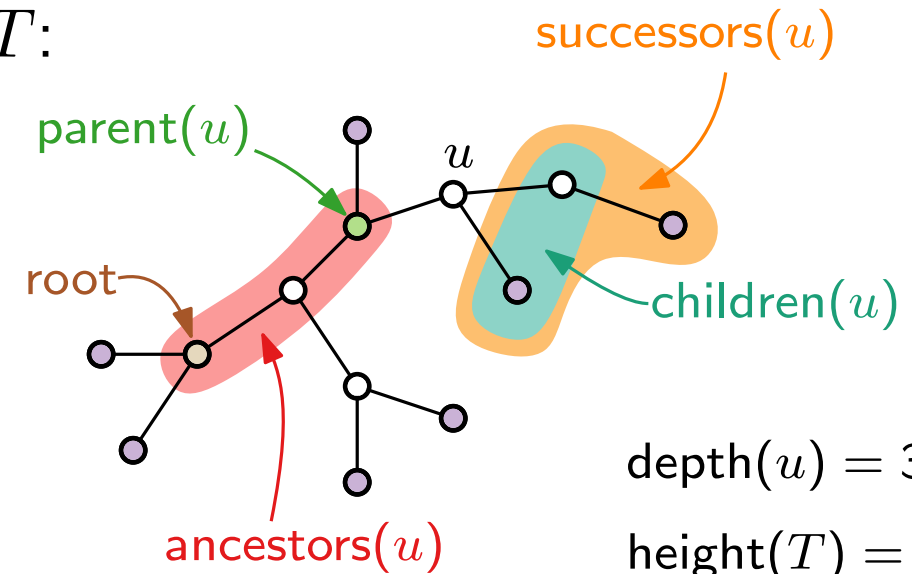

$\text{depth}(u) = 3$

$\text{height}(T) = 5$

(Rooted) Trees

Leaf: vertex of degree 1

Rooted tree: tree with a designated **root**

Ancestor: vertex on the path to the root

Parent: neighbor on the path to the root

Successor: vertex on the path away from the root

Child: neighbor not on the path to the root

Depth: length of the path to the root

Height: maximum depth of a leaf

Binary Tree: at most two children per vertex (*left* and *right* child)

3 types of tree traversals:

preorder

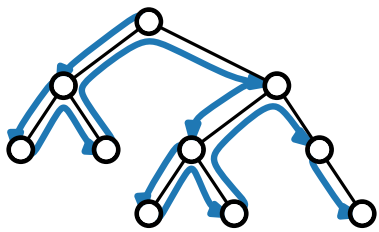

node – left – right

inorder

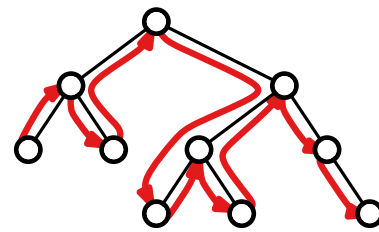

left – node – right

postorder

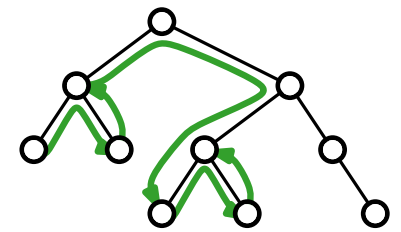

left – right – node

T :

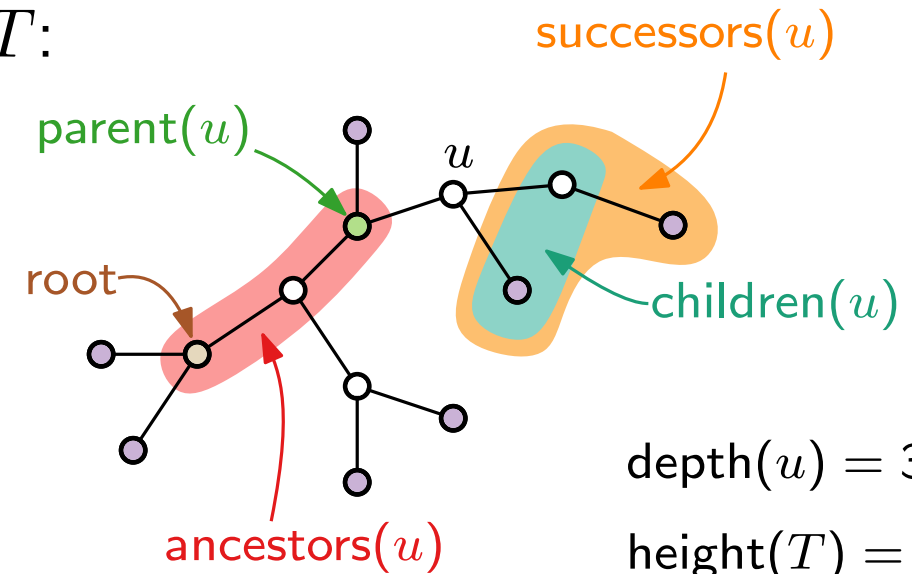

$\text{depth}(u) = 3$

$\text{height}(T) = 5$

(Rooted) Trees

Leaf: vertex of degree 1

Rooted tree: tree with a designated **root**

Ancestor: vertex on the path to the root

Parent: neighbor on the path to the root

Successor: vertex on the path away from the root

Child: neighbor not on the path to the root

Depth: length of the path to the root

Height: maximum depth of a leaf

Binary Tree: at most two children per vertex (*left* and *right* child)

3 types of tree traversals:

preorder

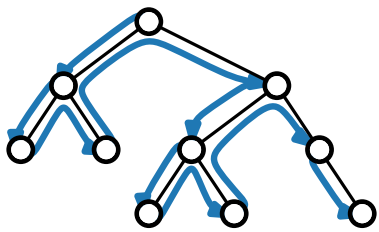

node – left – right

inorder

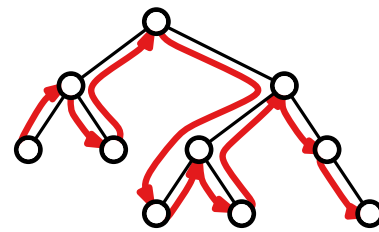

left – node – right

postorder

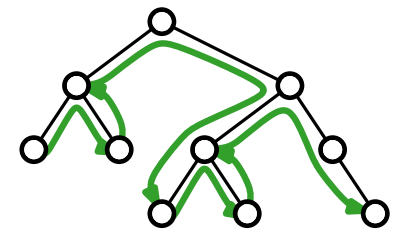

left – right – node

T :

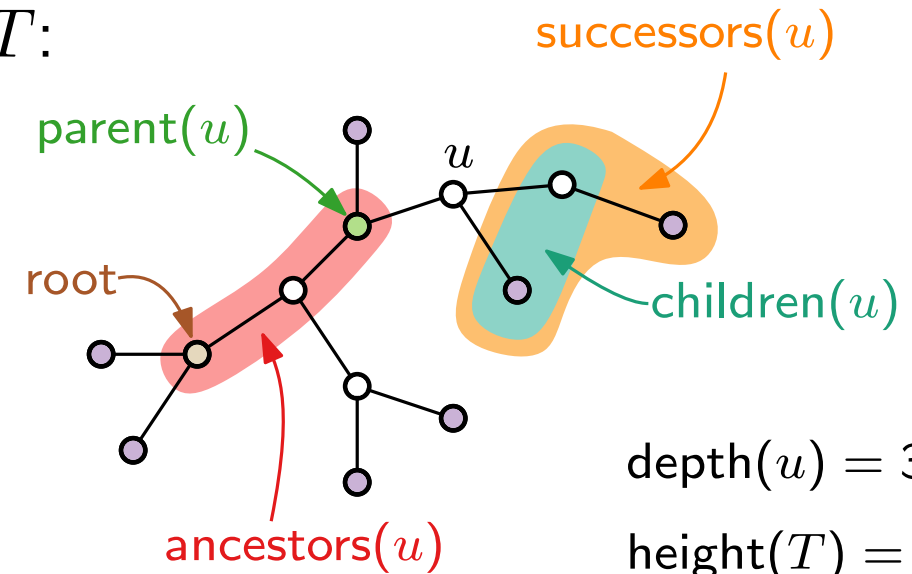

$\text{depth}(u) = 3$

$\text{height}(T) = 5$

(Rooted) Trees

Leaf: vertex of degree 1

Rooted tree: tree with a designated **root**

Ancestor: vertex on the path to the root

Parent: neighbor on the path to the root

Successor: vertex on the path away from the root

Child: neighbor not on the path to the root

Depth: length of the path to the root

Height: maximum depth of a leaf

Binary Tree: at most two children per vertex (*left* and *right* child)

3 types of tree traversals:

preorder

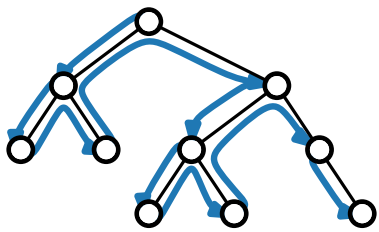

node – left – right

inorder

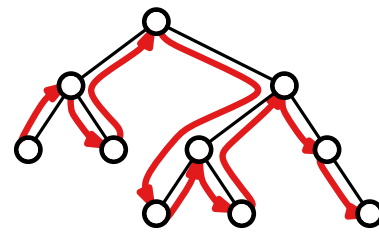

left – node – right

postorder

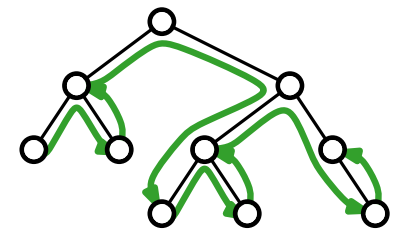

left – right – node

T :

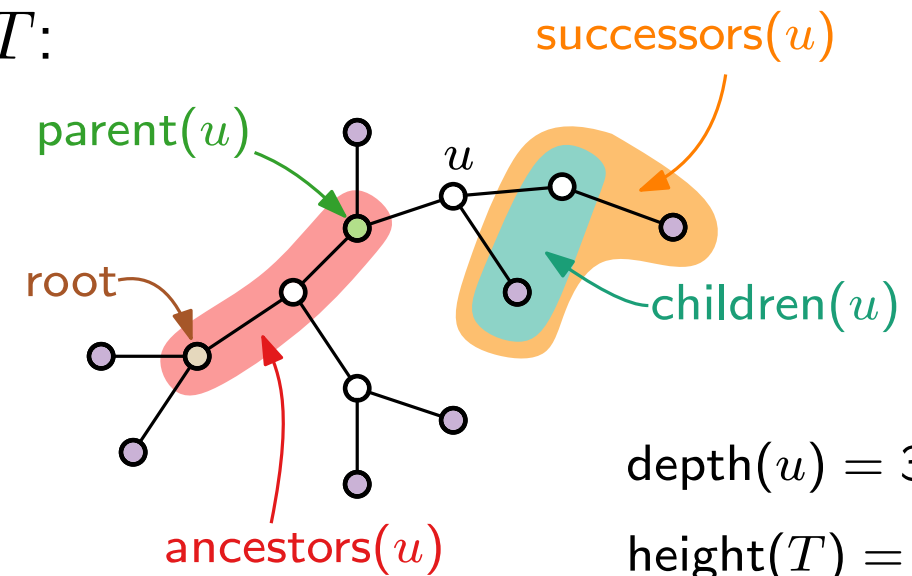

$\text{depth}(u) = 3$

$\text{height}(T) = 5$

(Rooted) Trees

Leaf: vertex of degree 1

Rooted tree: tree with a designated **root**

Ancestor: vertex on the path to the root

Parent: neighbor on the path to the root

Successor: vertex on the path away from the root

Child: neighbor not on the path to the root

Depth: length of the path to the root

Height: maximum depth of a leaf

Binary Tree: at most two children per vertex (*left* and *right* child)

3 types of tree traversals:

preorder

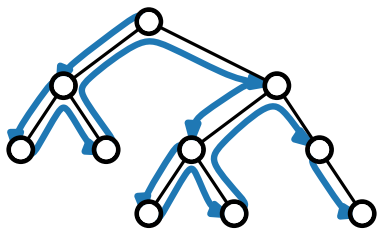

node – left – right

inorder

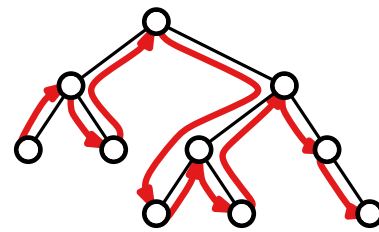

left – node – right

postorder

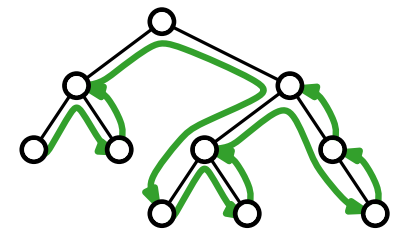

left – right – node

T :

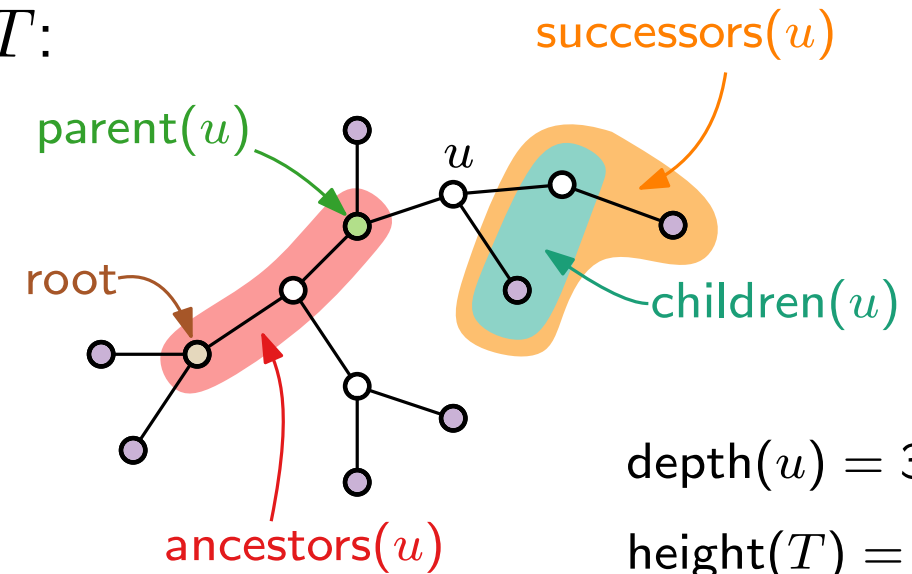

$\text{depth}(u) = 3$

$\text{height}(T) = 5$

(Rooted) Trees

Leaf: vertex of degree 1

Rooted tree: tree with a designated **root**

Ancestor: vertex on the path to the root

Parent: neighbor on the path to the root

Successor: vertex on the path away from the root

Child: neighbor not on the path to the root

Depth: length of the path to the root

Height: maximum depth of a leaf

Binary Tree: at most two children per vertex (*left* and *right* child)

3 types of tree traversals:

preorder

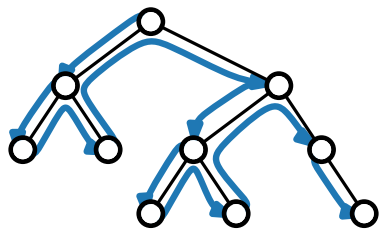

node – left – right

inorder

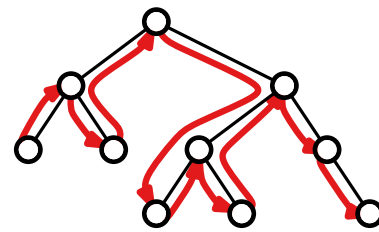

left – node – right

postorder

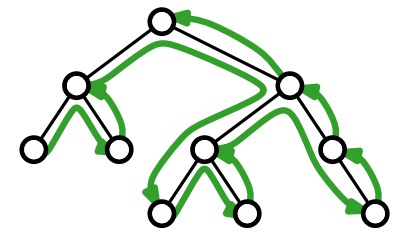

left – right – node

T :

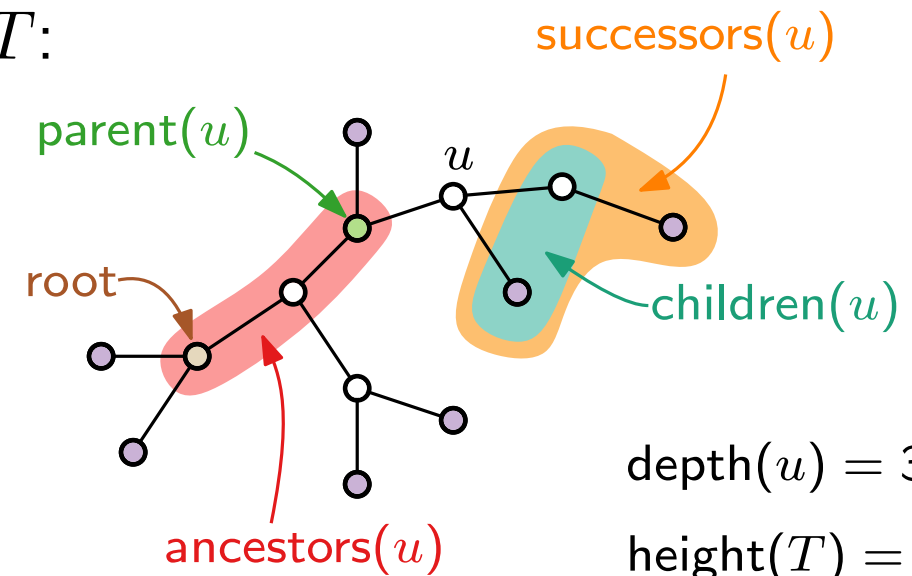

$\text{depth}(u) = 3$

$\text{height}(T) = 5$

First Grid Layout of Binary Trees

1. Choose y-coordinates:

First Grid Layout of Binary Trees

1. Choose y-coordinates:

2. Choose x-coordinates:

First Grid Layout of Binary Trees

1. Choose y-coordinates: $y(u) = \text{depth}(u)$

2. Choose x-coordinates:

First Grid Layout of Binary Trees

1. Choose y-coordinates: $y(u) = \text{depth}(u)$

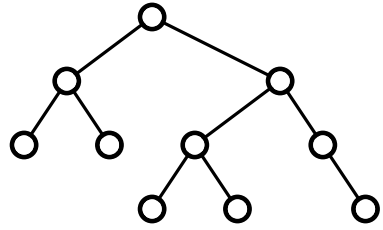

2. Choose x-coordinates:

First Grid Layout of Binary Trees

1. Choose y-coordinates: $y(u) = \text{depth}(u)$

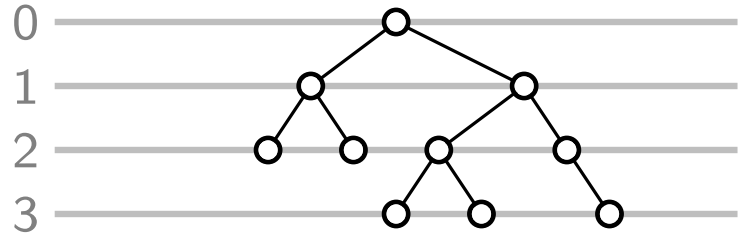

2. Choose x-coordinates:

First Grid Layout of Binary Trees

1. Choose y-coordinates: $y(u) = \text{depth}(u)$

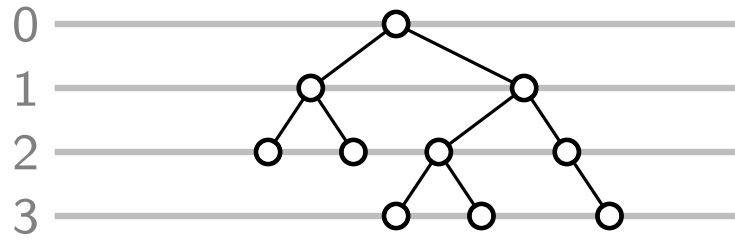

2. Choose x-coordinates:

preorder

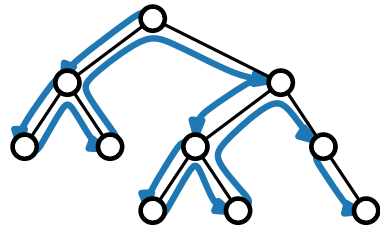

inorder

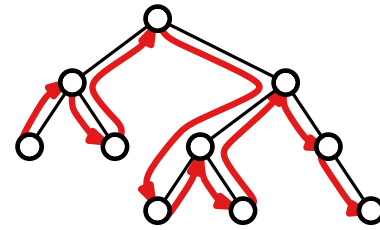

postorder

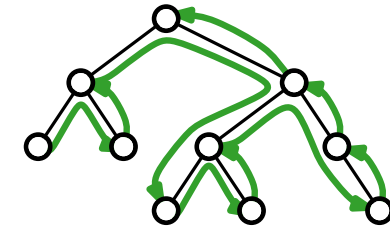

First Grid Layout of Binary Trees

1. Choose y-coordinates: $y(u) = \text{depth}(u)$

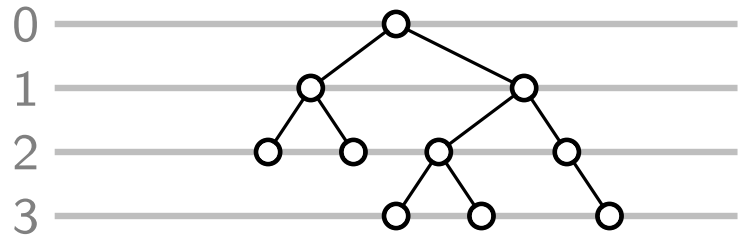

2. Choose x-coordinates:

preorder

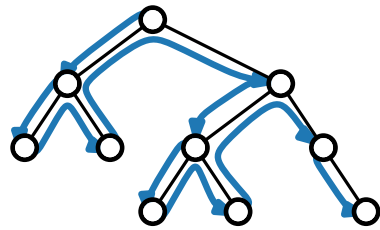

inorder

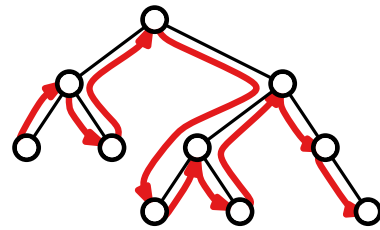

postorder

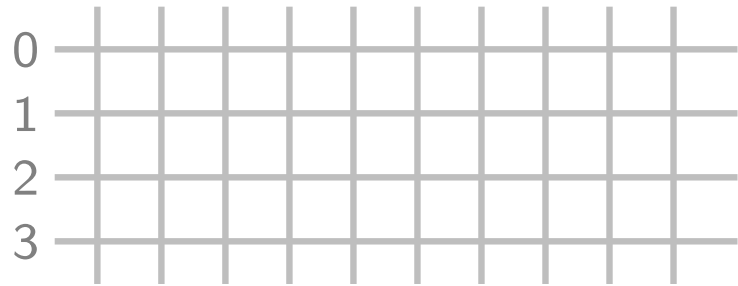
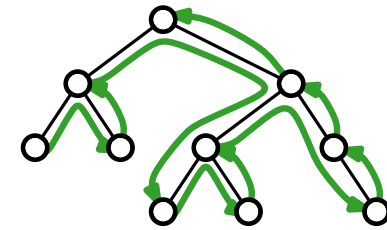

First Grid Layout of Binary Trees

1. Choose y-coordinates: $y(u) = \text{depth}(u)$

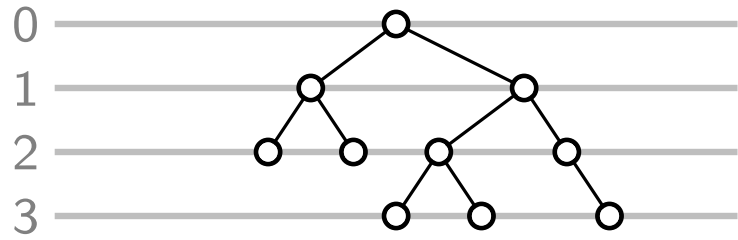

2. Choose x-coordinates:

preorder

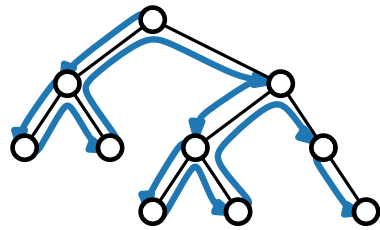

inorder

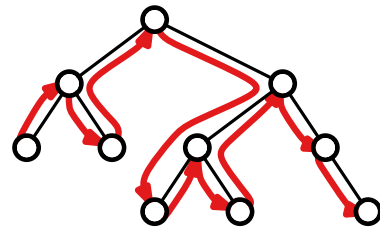

postorder

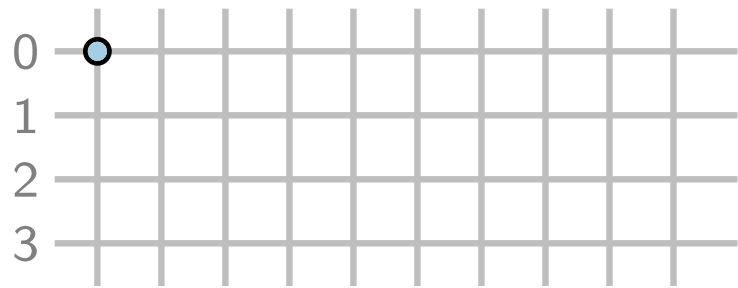
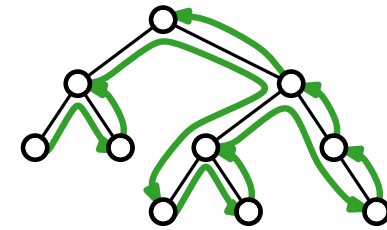

First Grid Layout of Binary Trees

1. Choose y-coordinates: $y(u) = \text{depth}(u)$

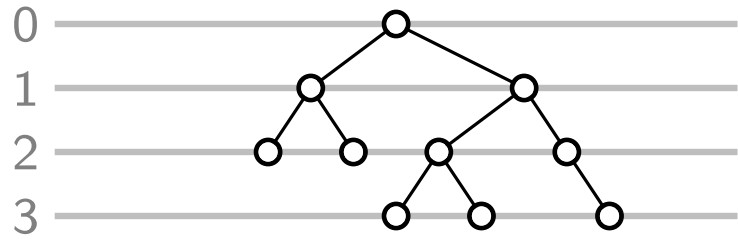

2. Choose x-coordinates:

preorder

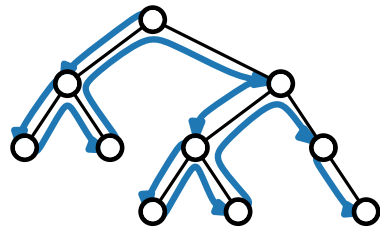

inorder

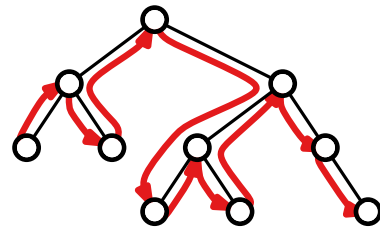

postorder

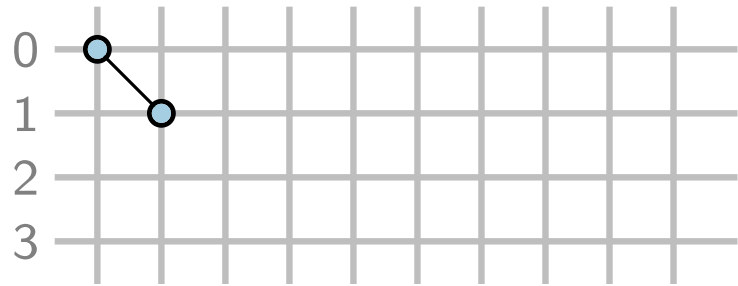
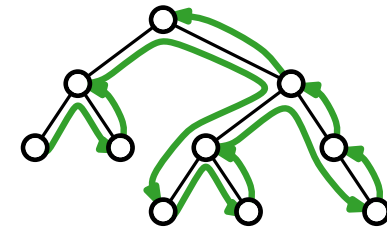

First Grid Layout of Binary Trees

1. Choose y-coordinates: $y(u) = \text{depth}(u)$

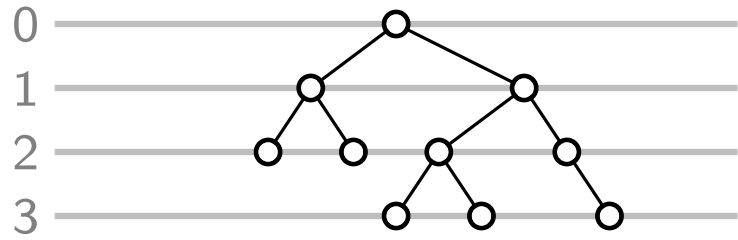

2. Choose x-coordinates:

preorder

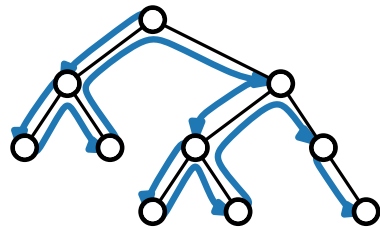

inorder

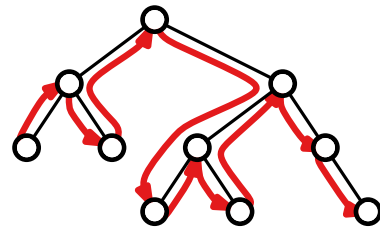

postorder

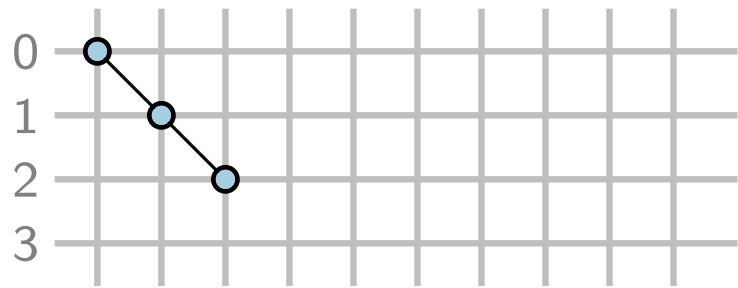
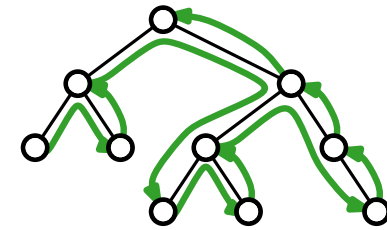

First Grid Layout of Binary Trees

1. Choose y-coordinates: $y(u) = \text{depth}(u)$

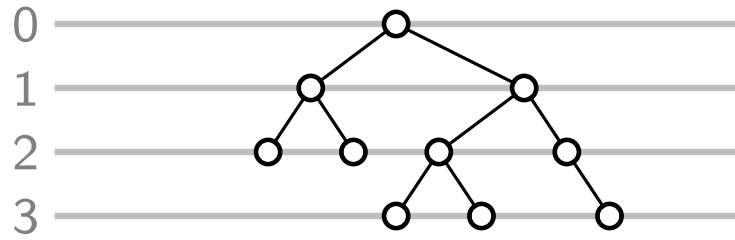

2. Choose x-coordinates:

preorder

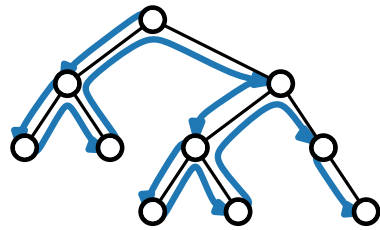

inorder

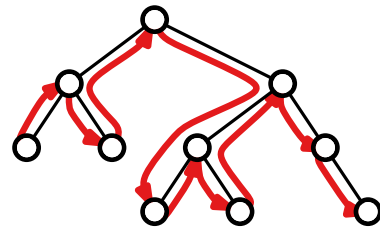

postorder

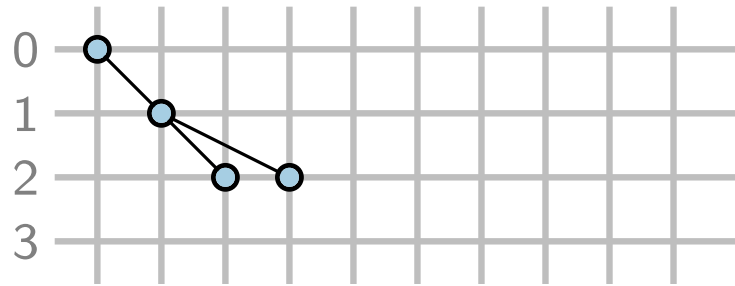
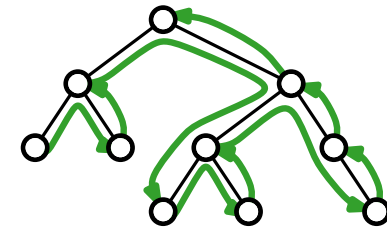

First Grid Layout of Binary Trees

1. Choose y-coordinates: $y(u) = \text{depth}(u)$

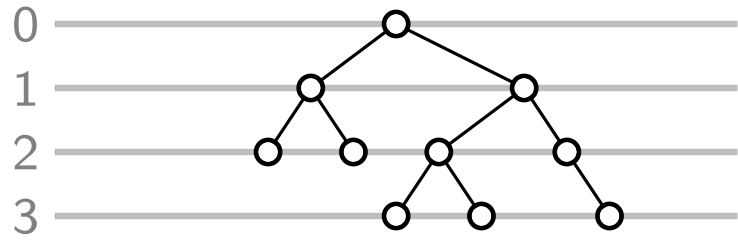

2. Choose x-coordinates:

preorder

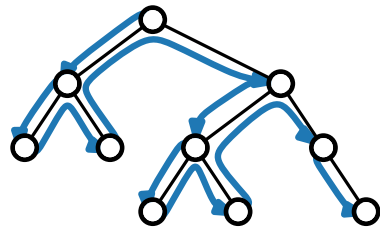

inorder

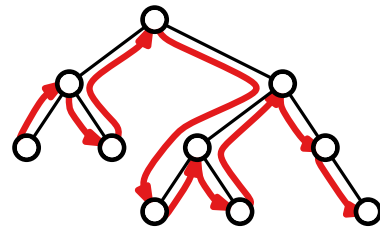

postorder

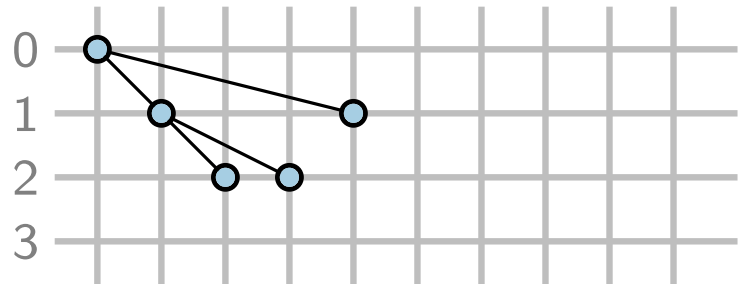
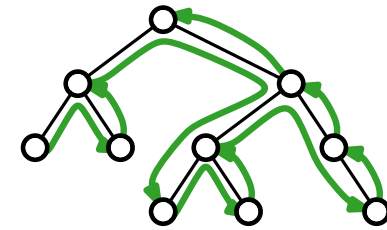

First Grid Layout of Binary Trees

1. Choose y-coordinates: $y(u) = \text{depth}(u)$

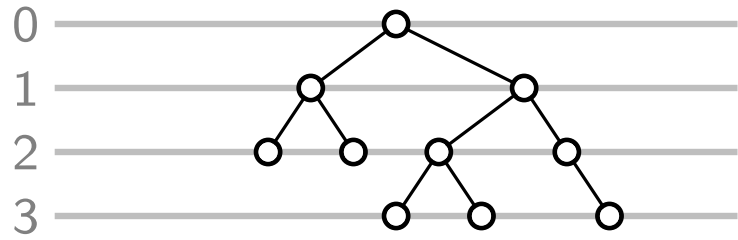

2. Choose x-coordinates:

preorder

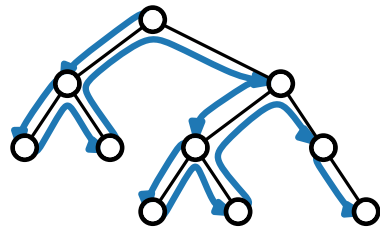

inorder

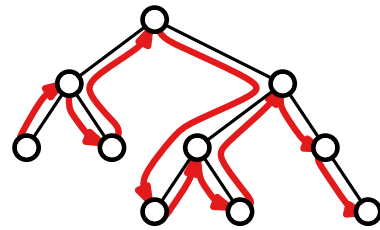

postorder

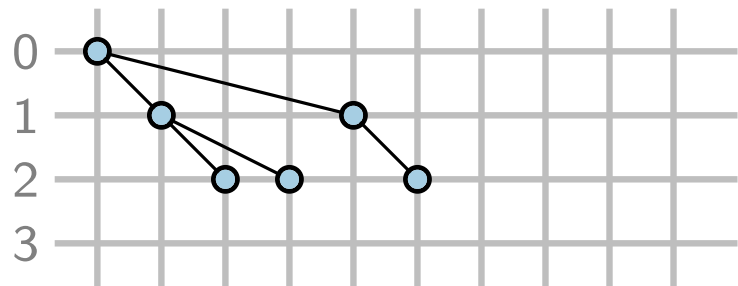
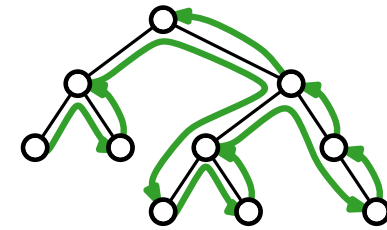

First Grid Layout of Binary Trees

1. Choose y-coordinates: $y(u) = \text{depth}(u)$

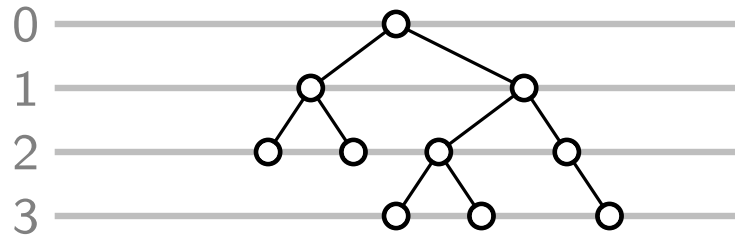

2. Choose x-coordinates:

preorder

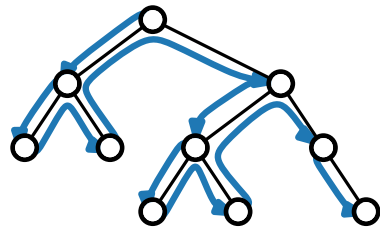

inorder

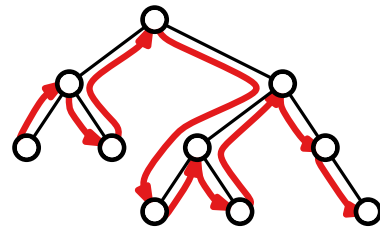

postorder

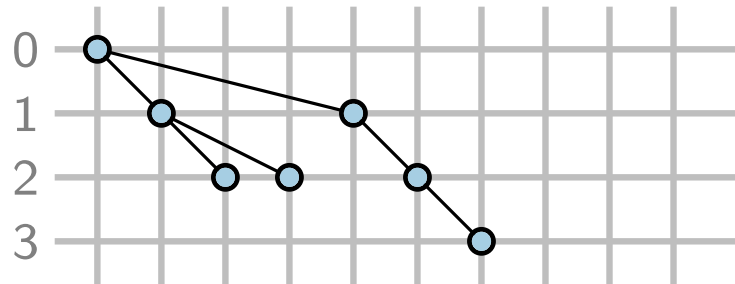
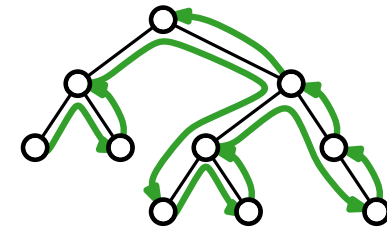

First Grid Layout of Binary Trees

1. Choose y-coordinates: $y(u) = \text{depth}(u)$

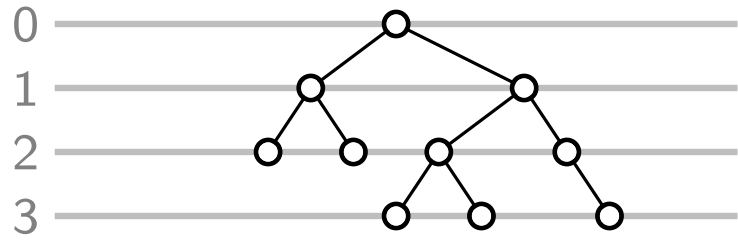

2. Choose x-coordinates:

preorder

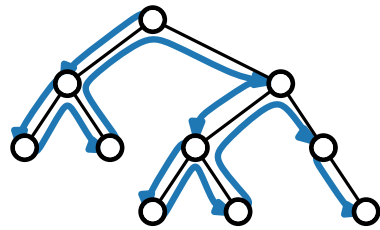

inorder

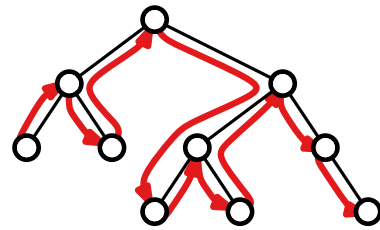

postorder

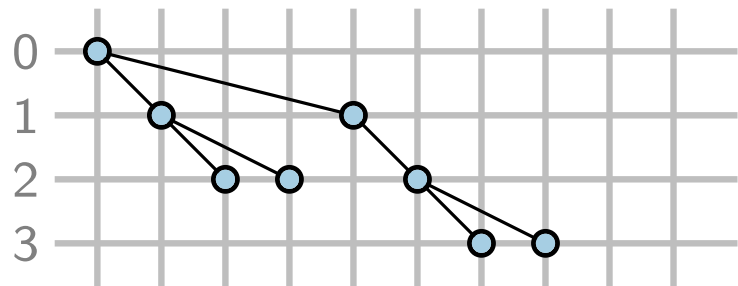
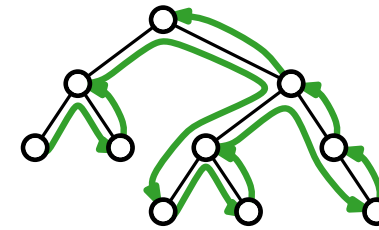

First Grid Layout of Binary Trees

1. Choose y-coordinates: $y(u) = \text{depth}(u)$

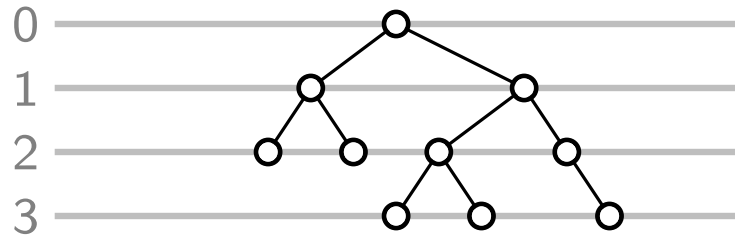

2. Choose x-coordinates:

preorder

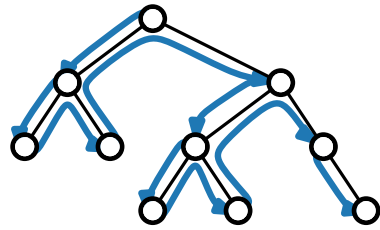

inorder

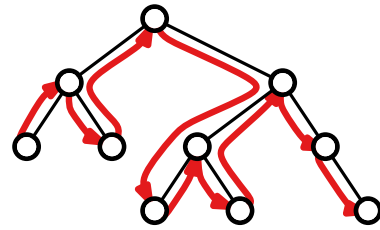

postorder

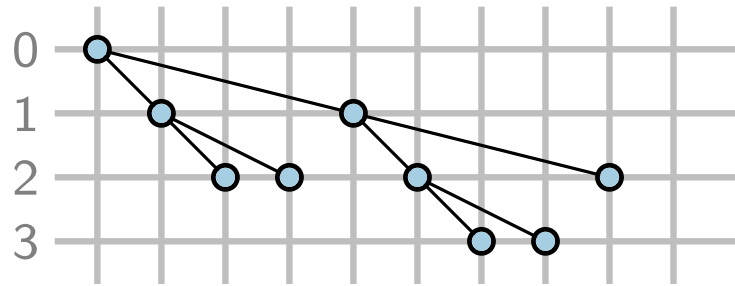
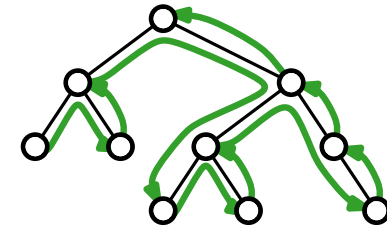

First Grid Layout of Binary Trees

1. Choose y-coordinates: $y(u) = \text{depth}(u)$

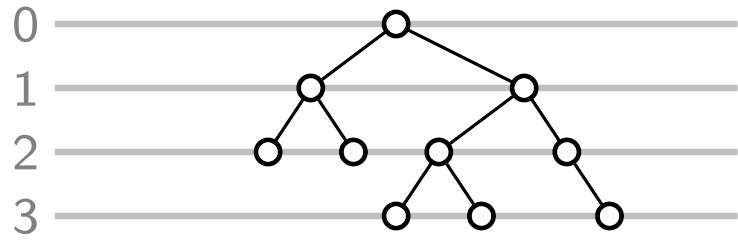

2. Choose x-coordinates:

preorder

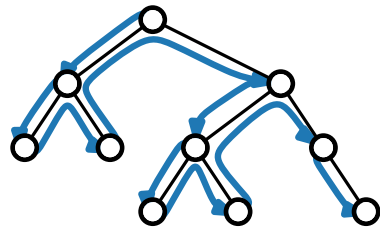

inorder

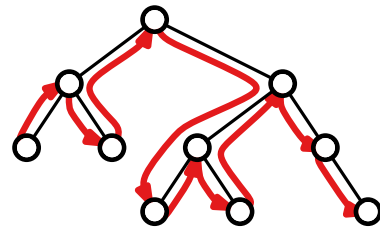

postorder

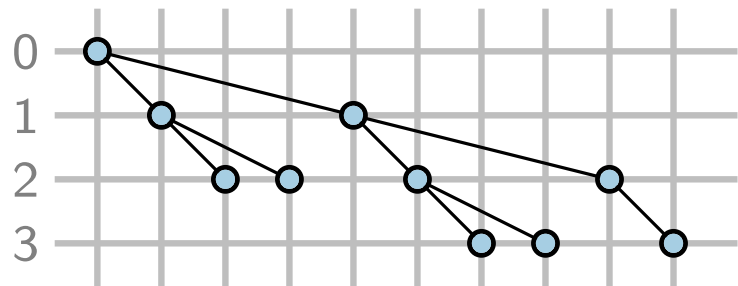
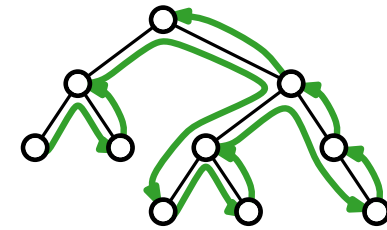

First Grid Layout of Binary Trees

1. Choose y-coordinates: $y(u) = \text{depth}(u)$

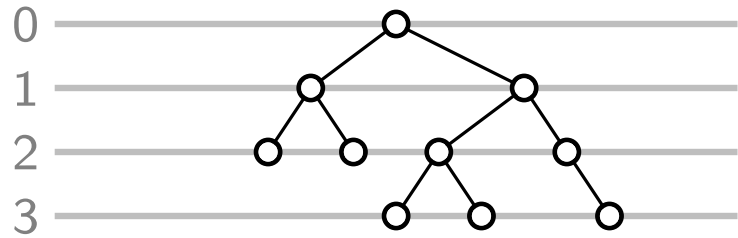

2. Choose x-coordinates:

preorder

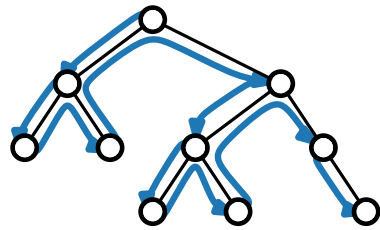

inorder

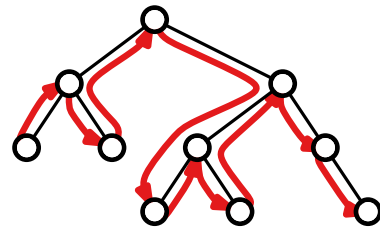

postorder

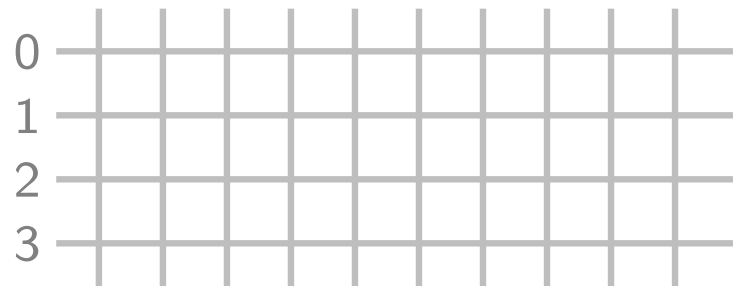
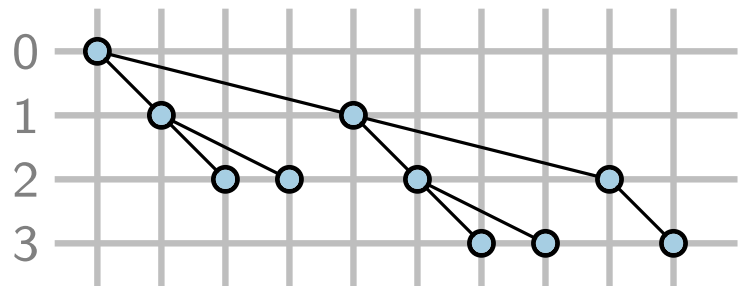
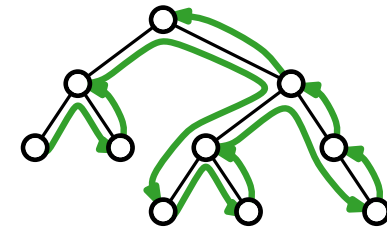

First Grid Layout of Binary Trees

1. Choose y-coordinates: $y(u) = \text{depth}(u)$

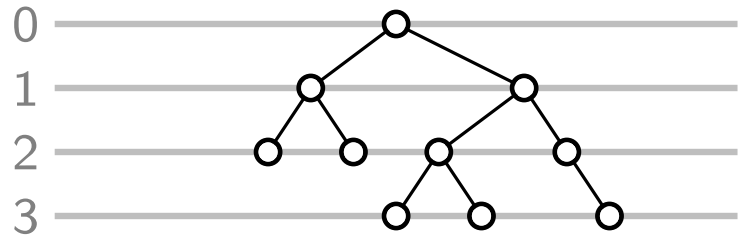

2. Choose x-coordinates:

preorder

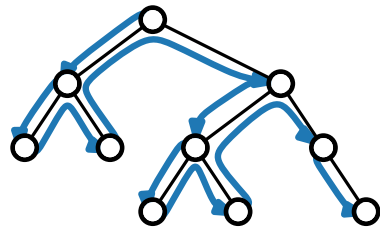

inorder

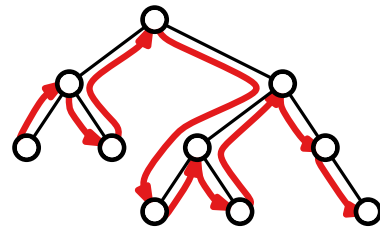

postorder

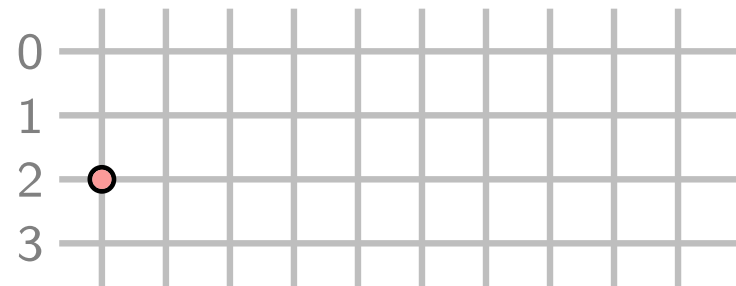
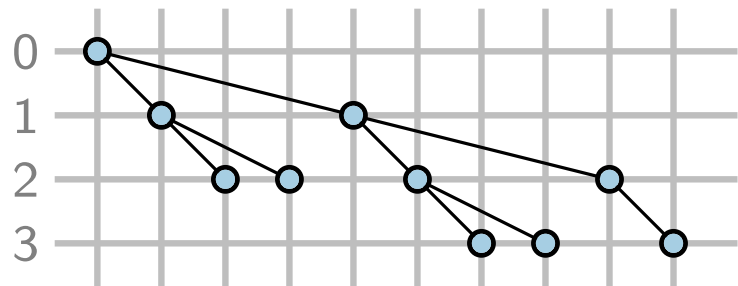
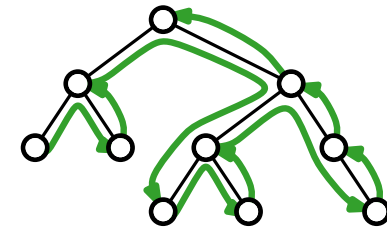

First Grid Layout of Binary Trees

1. Choose y-coordinates: $y(u) = \text{depth}(u)$

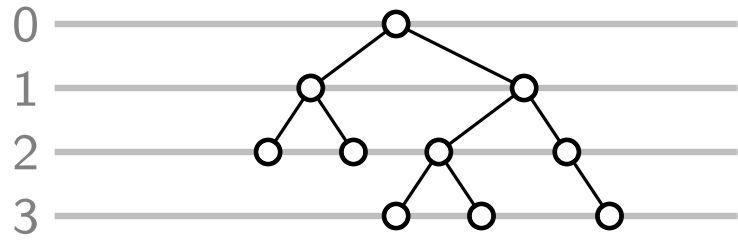

2. Choose x-coordinates:

preorder

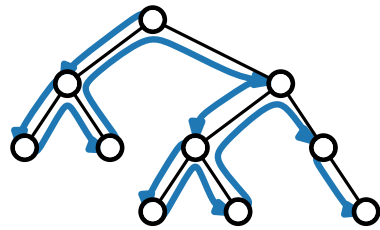

inorder

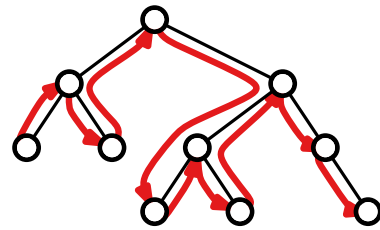

postorder

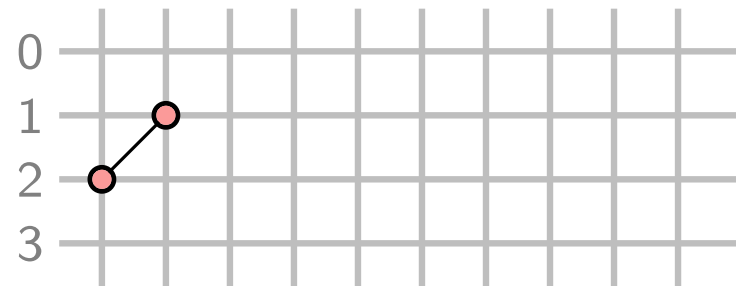
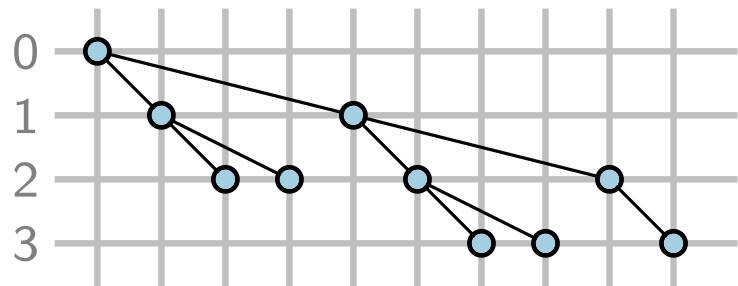
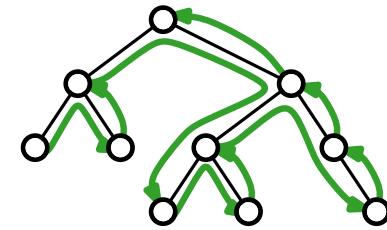

First Grid Layout of Binary Trees

1. Choose y-coordinates: $y(u) = \text{depth}(u)$

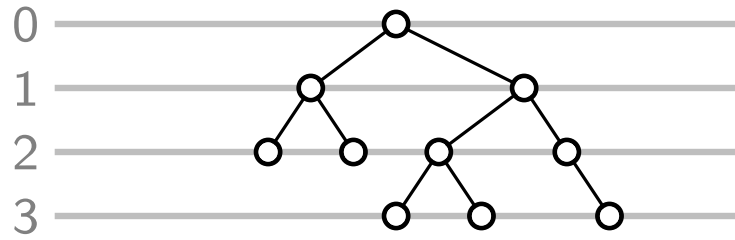

2. Choose x-coordinates:

preorder

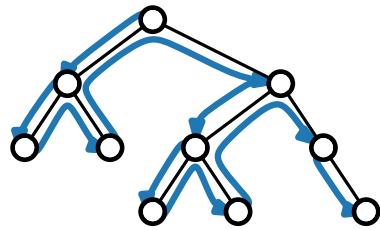

inorder

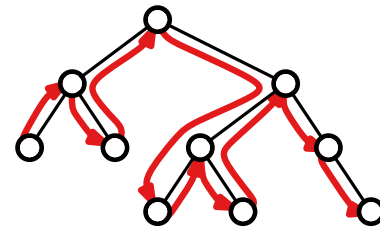

postorder

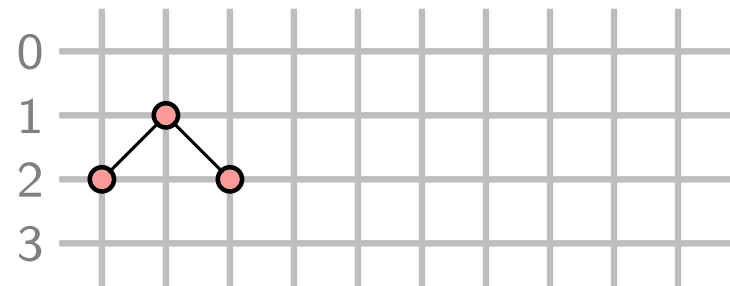
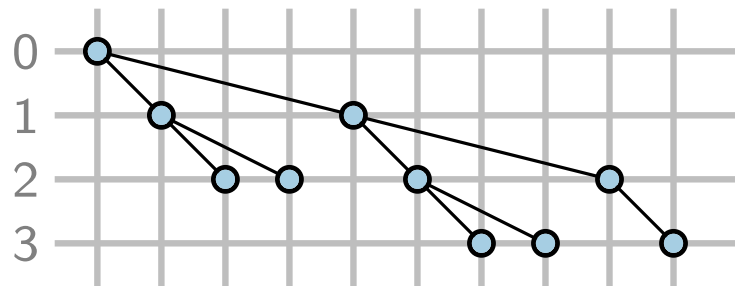
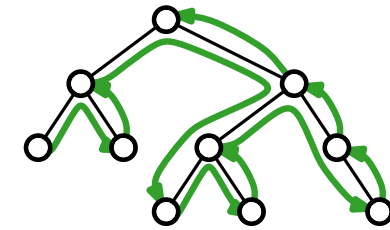

First Grid Layout of Binary Trees

1. Choose y-coordinates: $y(u) = \text{depth}(u)$

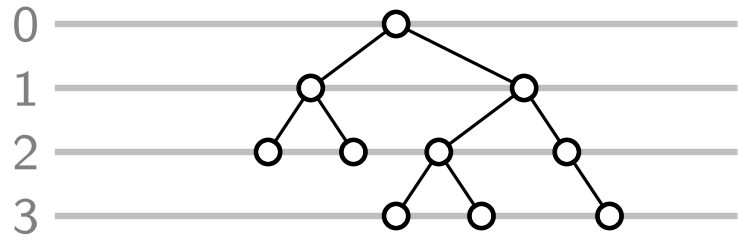

2. Choose x-coordinates:

preorder

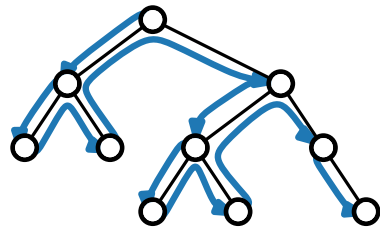

inorder



postorder

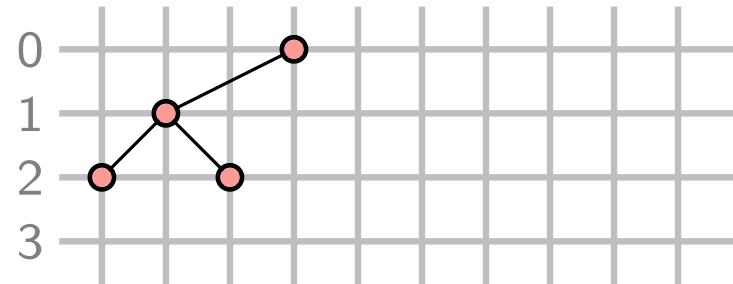
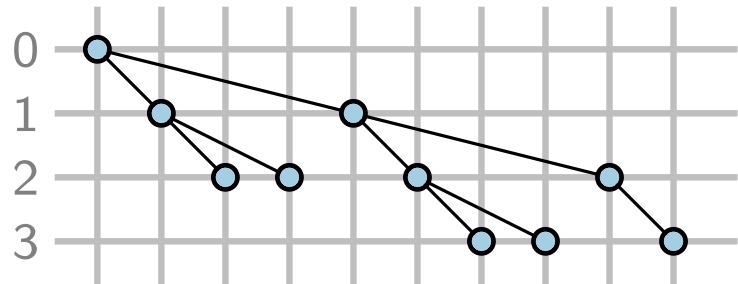
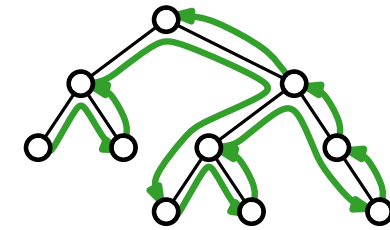

First Grid Layout of Binary Trees

1. Choose y-coordinates: $y(u) = \text{depth}(u)$

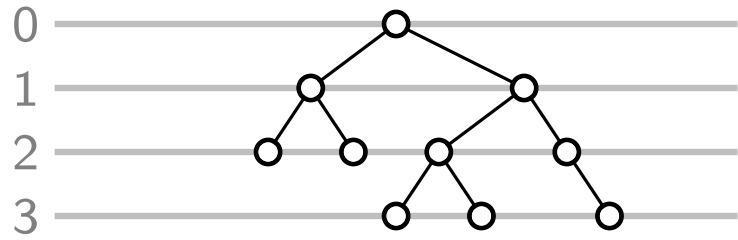

2. Choose x-coordinates:

preorder

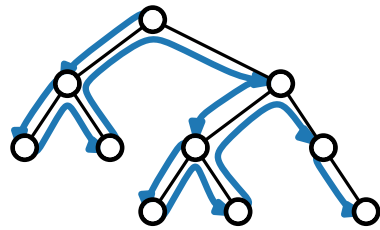

inorder

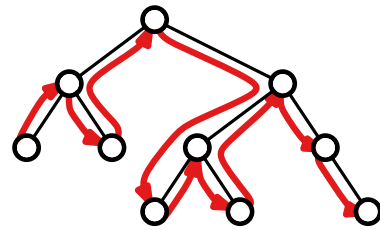

postorder

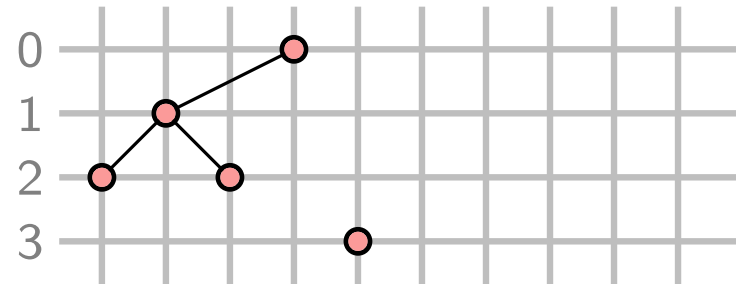
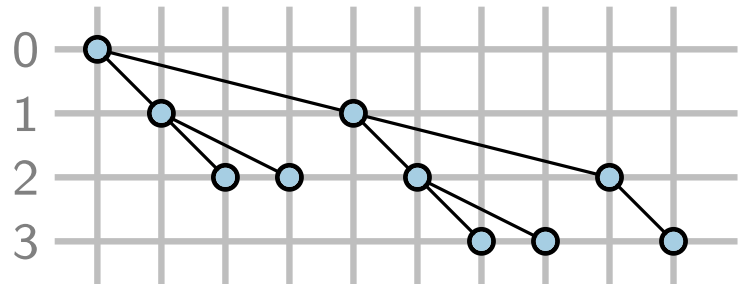
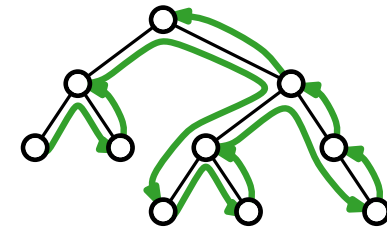

First Grid Layout of Binary Trees

1. Choose y-coordinates: $y(u) = \text{depth}(u)$

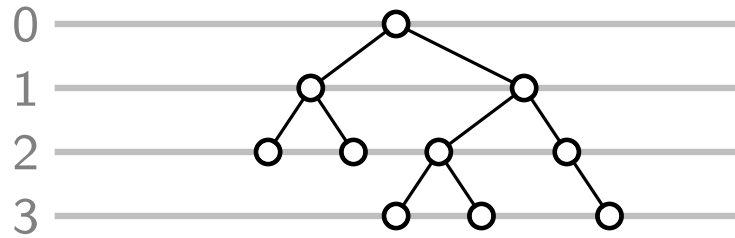

2. Choose x-coordinates:

preorder

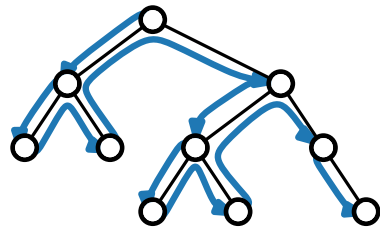

inorder

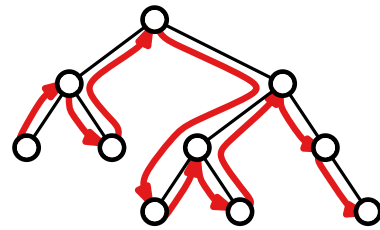

postorder

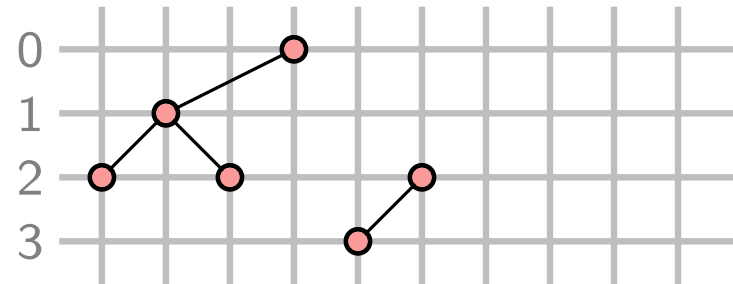
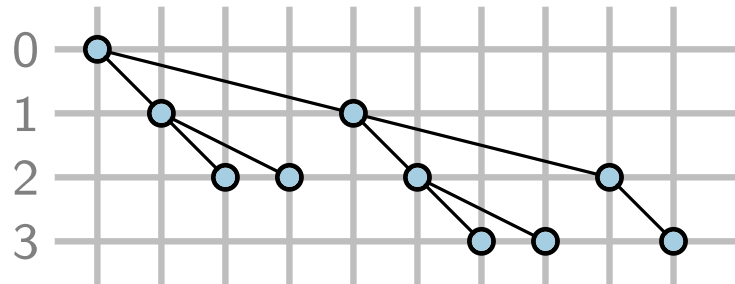
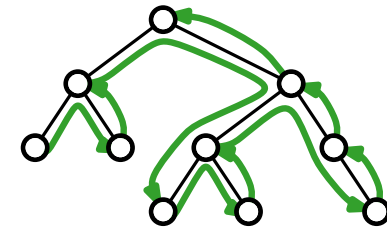

First Grid Layout of Binary Trees

1. Choose y-coordinates: $y(u) = \text{depth}(u)$

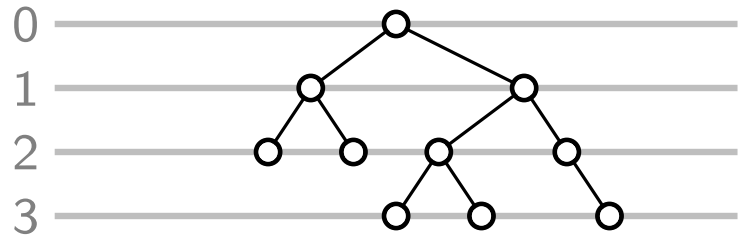

2. Choose x-coordinates:

preorder

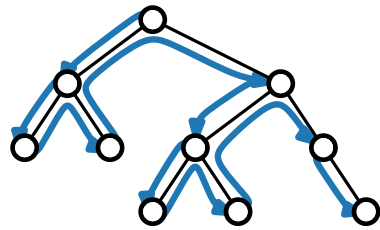

inorder

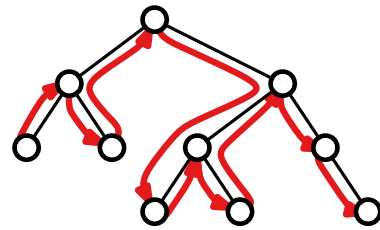

postorder

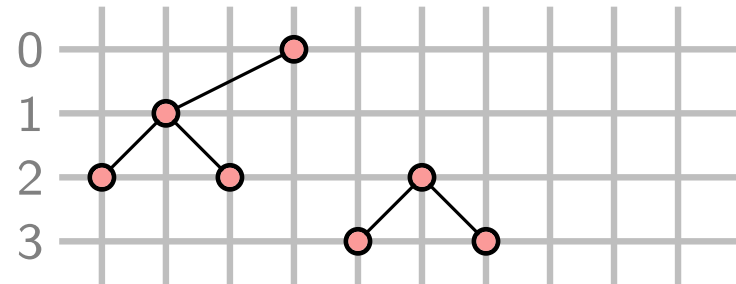
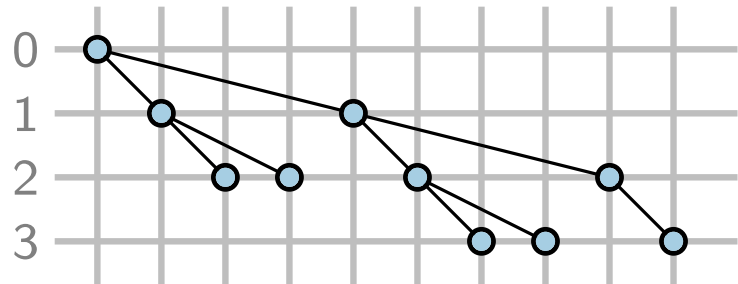
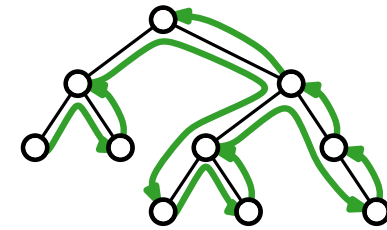

First Grid Layout of Binary Trees

1. Choose y-coordinates: $y(u) = \text{depth}(u)$

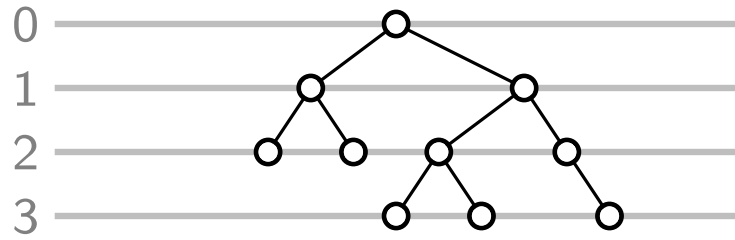

2. Choose x-coordinates:

preorder

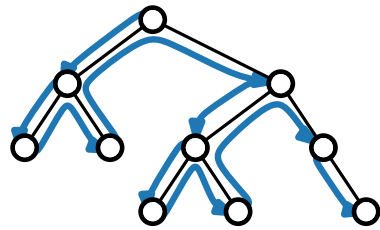

inorder

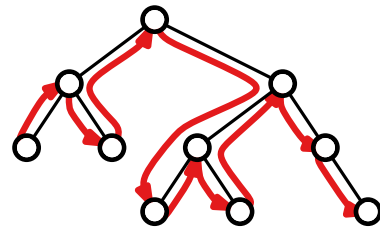

postorder

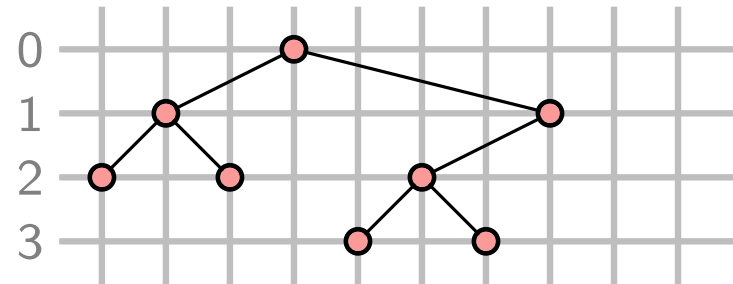
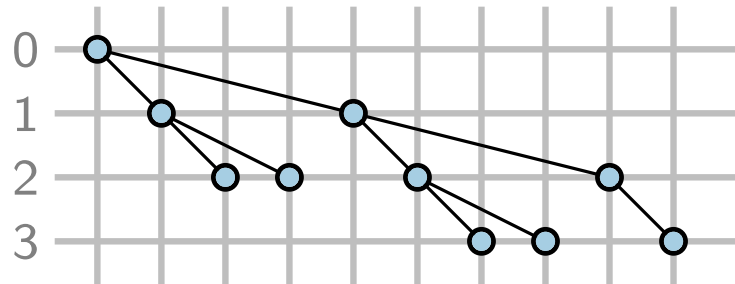
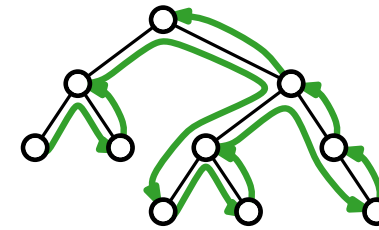

First Grid Layout of Binary Trees

1. Choose y-coordinates: $y(u) = \text{depth}(u)$

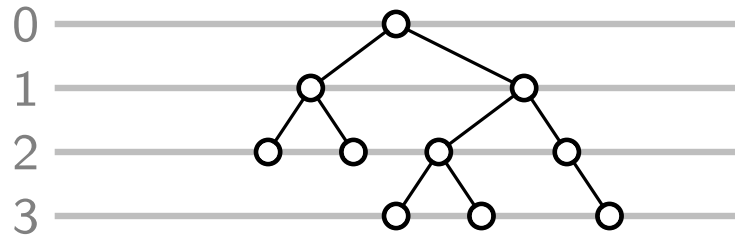

2. Choose x-coordinates:

preorder

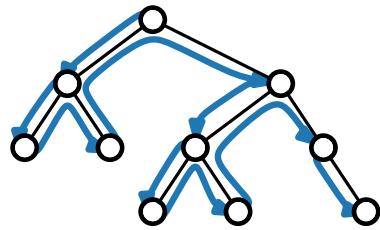

inorder

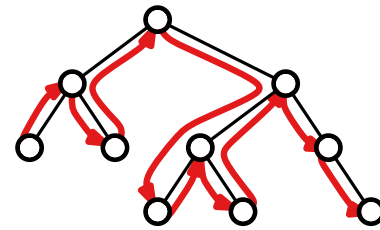

postorder

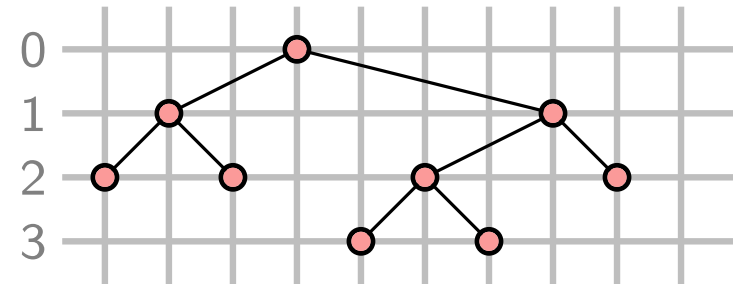
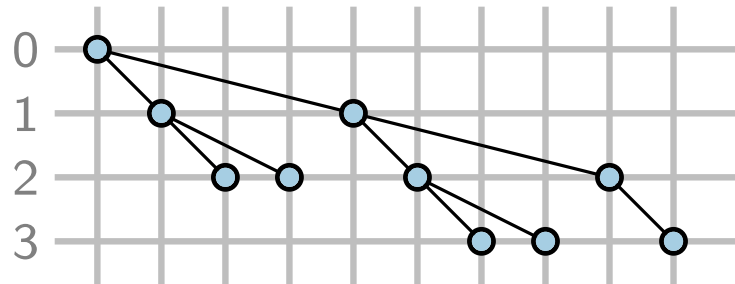
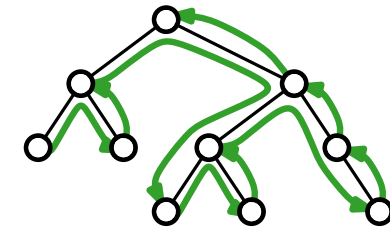

First Grid Layout of Binary Trees

1. Choose y-coordinates: $y(u) = \text{depth}(u)$

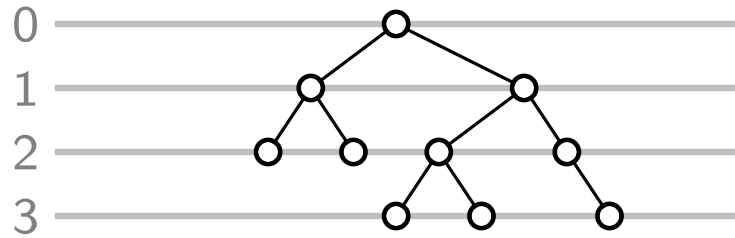

2. Choose x-coordinates:

preorder

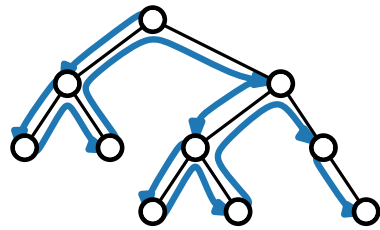

inorder

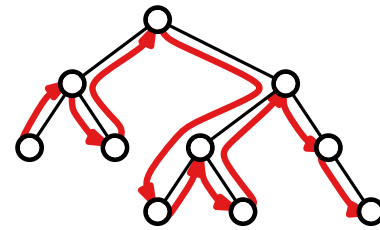

postorder

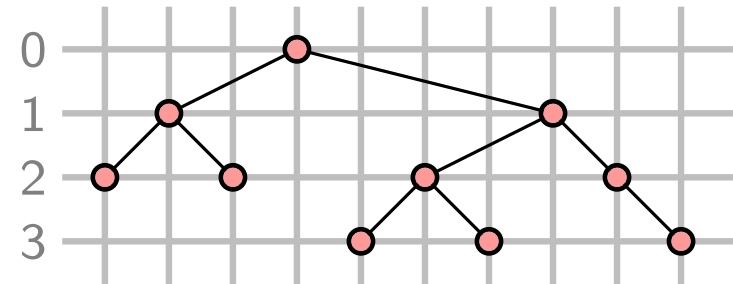
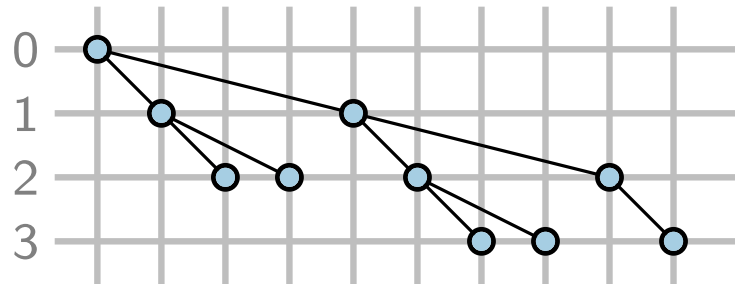
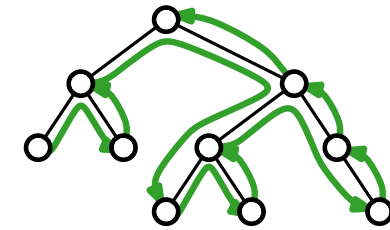

First Grid Layout of Binary Trees

1. Choose y-coordinates: $y(u) = \text{depth}(u)$

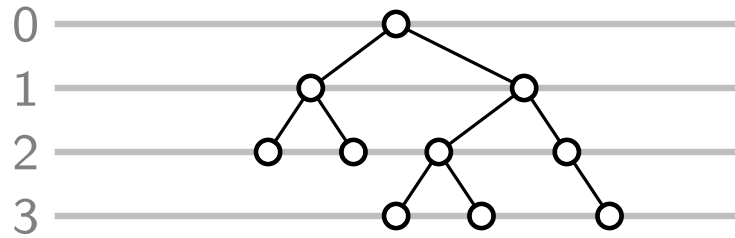

2. Choose x-coordinates:

preorder

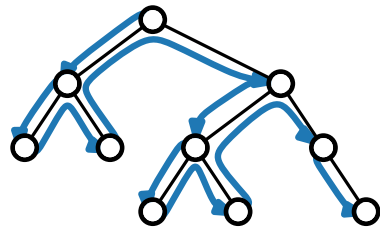

inorder

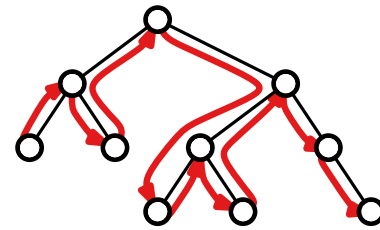

postorder

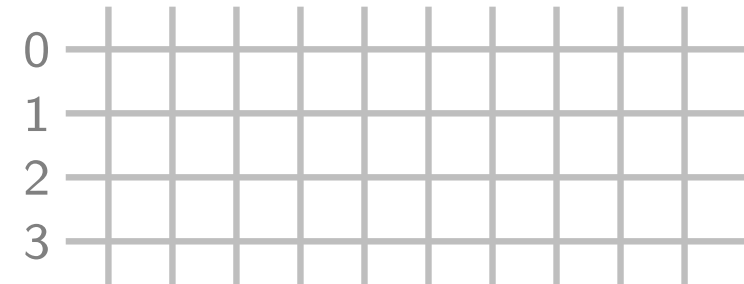
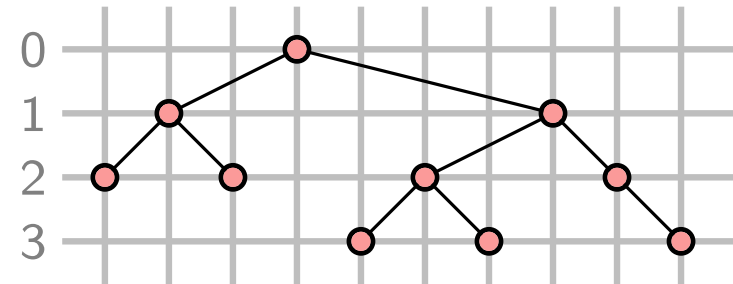
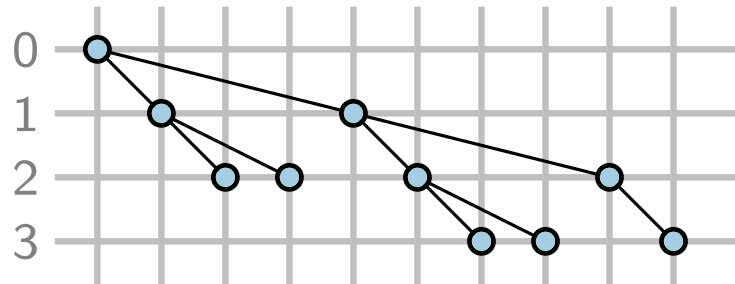
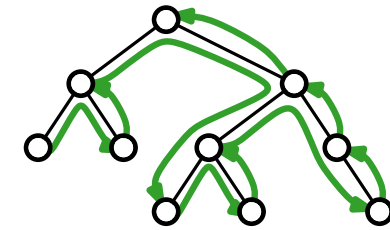

First Grid Layout of Binary Trees

1. Choose y-coordinates: $y(u) = \text{depth}(u)$

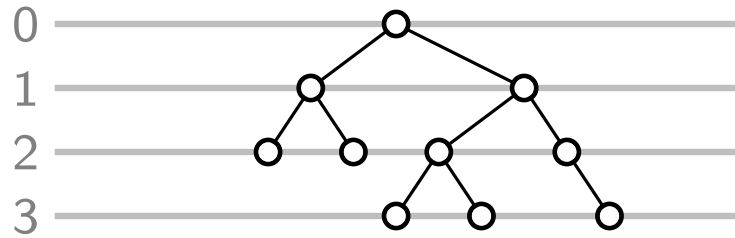

2. Choose x-coordinates:

preorder

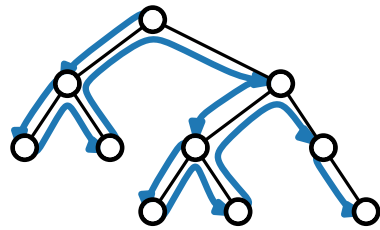

inorder

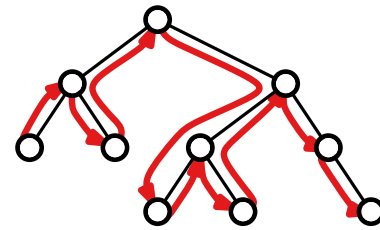

postorder

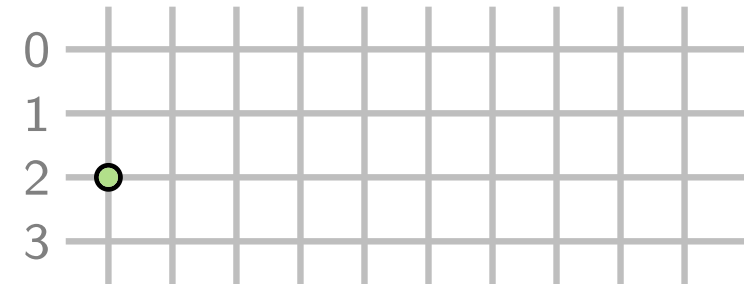
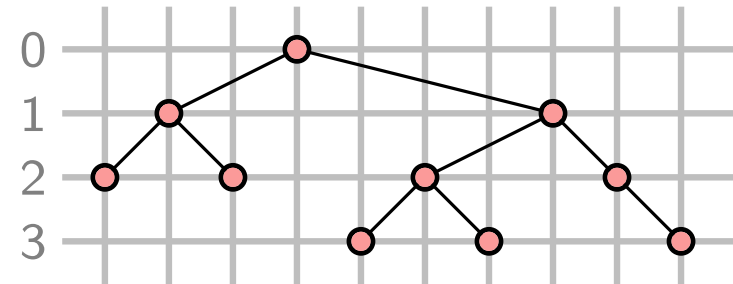
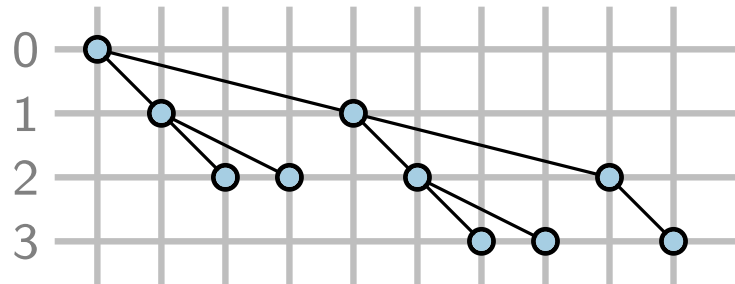
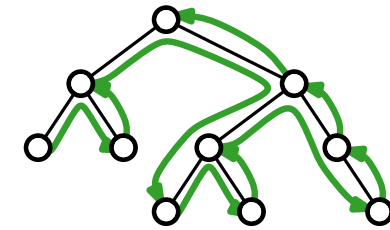

First Grid Layout of Binary Trees

1. Choose y-coordinates: $y(u) = \text{depth}(u)$

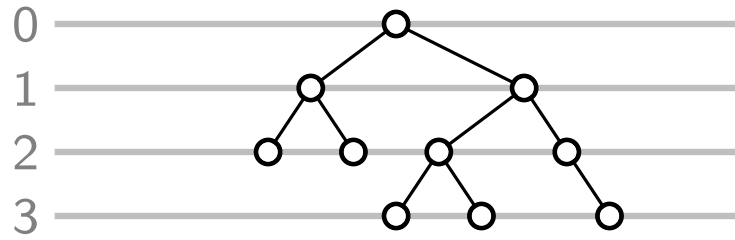

2. Choose x-coordinates:

preorder

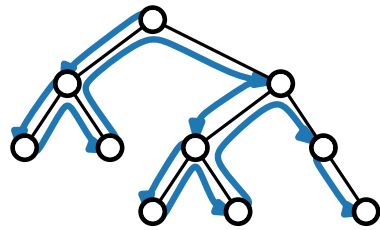

inorder

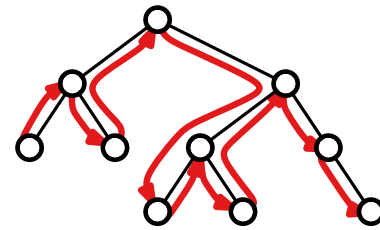

postorder

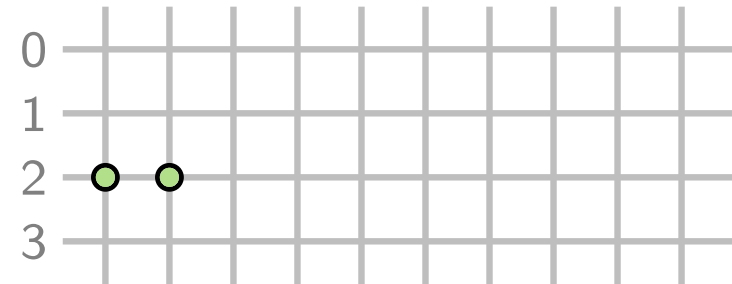
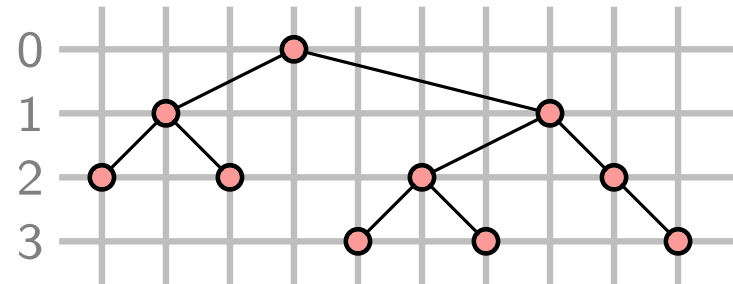
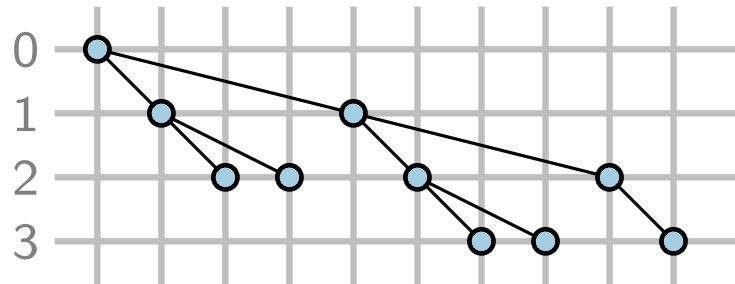
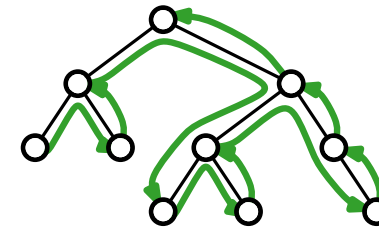

First Grid Layout of Binary Trees

1. Choose y-coordinates: $y(u) = \text{depth}(u)$

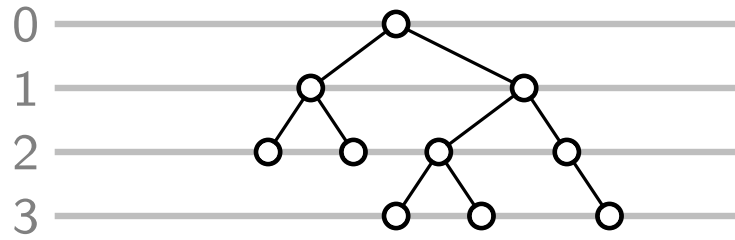

2. Choose x-coordinates:

preorder

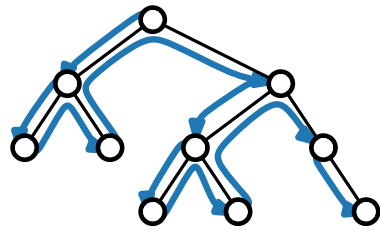

inorder

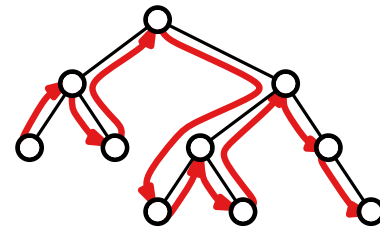

postorder

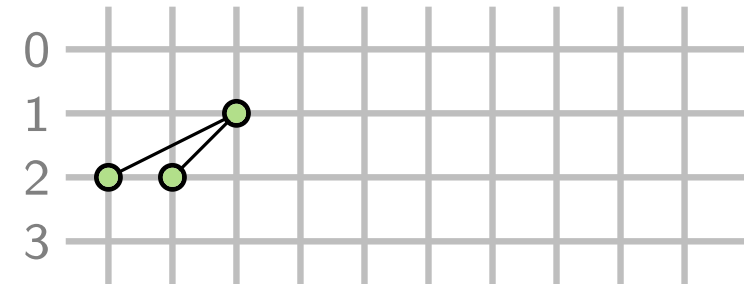
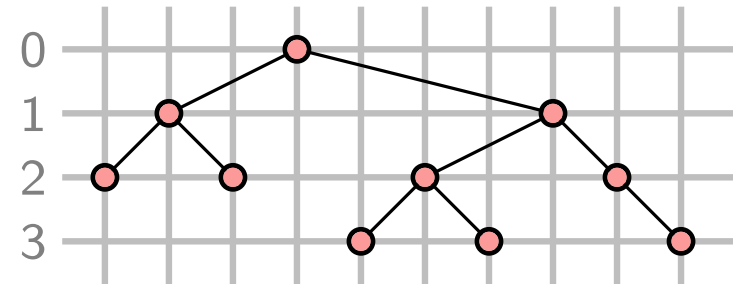
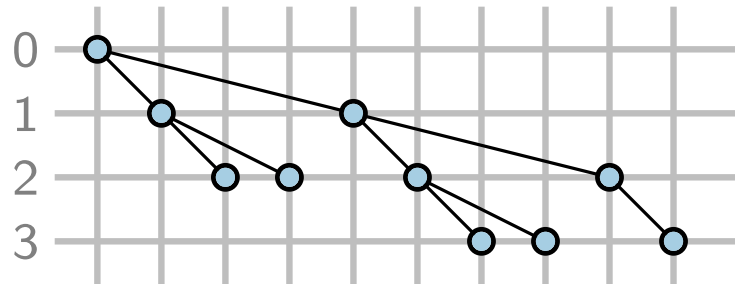
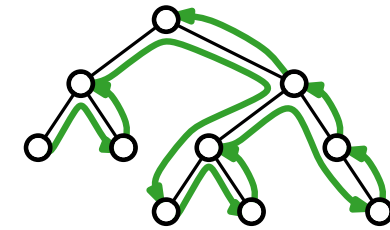

First Grid Layout of Binary Trees

1. Choose y-coordinates: $y(u) = \text{depth}(u)$

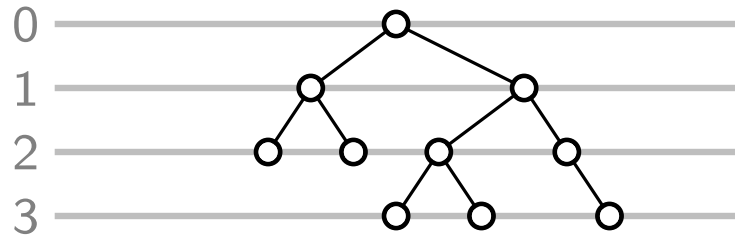

2. Choose x-coordinates:

preorder

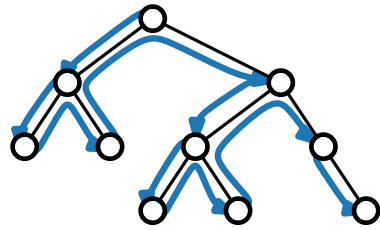

inorder

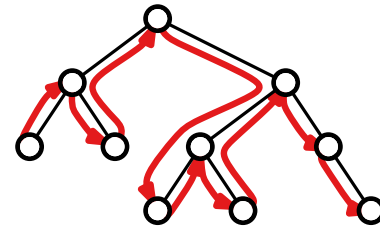

postorder

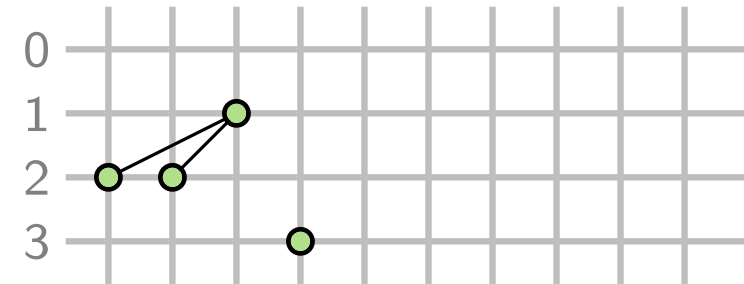
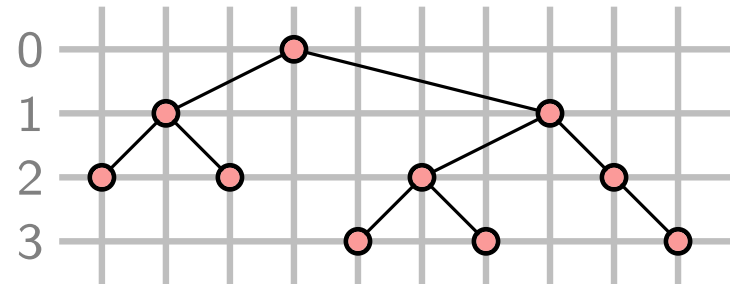
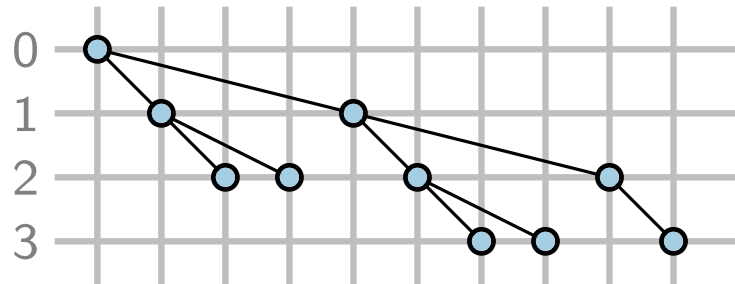
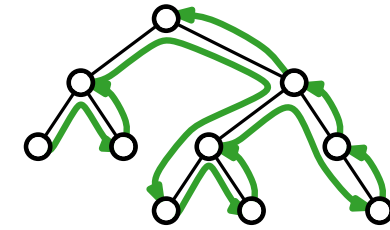

First Grid Layout of Binary Trees

1. Choose y-coordinates: $y(u) = \text{depth}(u)$

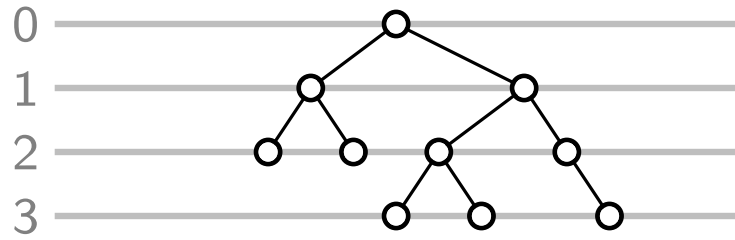

2. Choose x-coordinates:

preorder

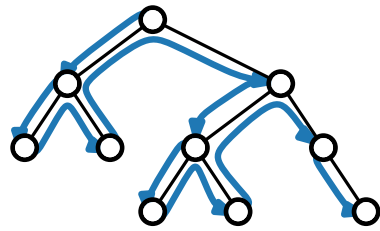

inorder

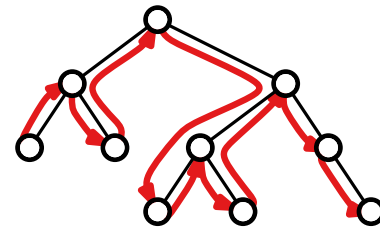

postorder

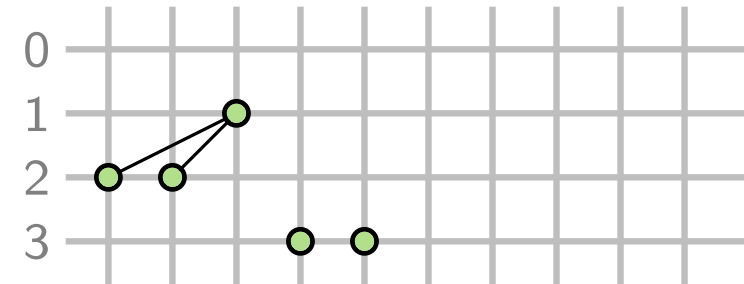
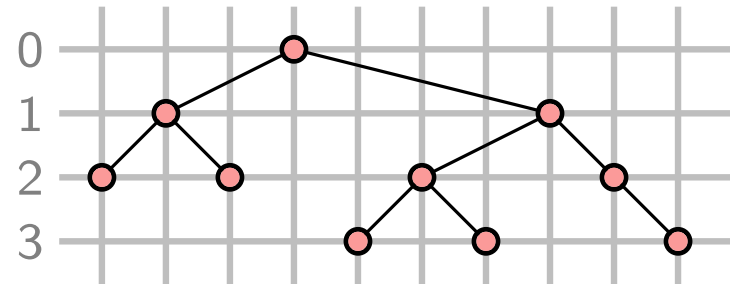
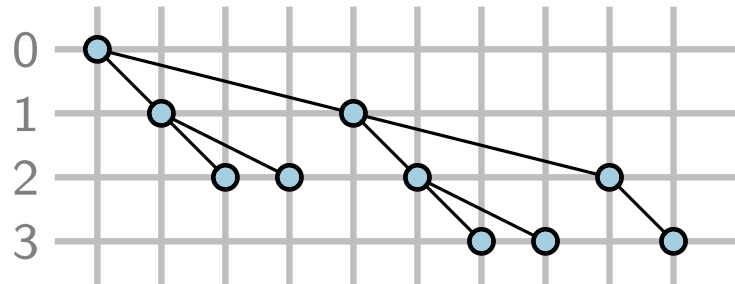
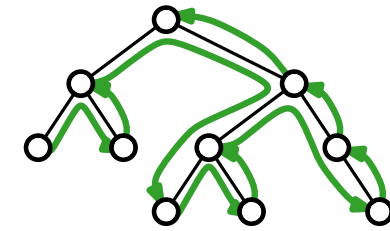

First Grid Layout of Binary Trees

1. Choose y-coordinates: $y(u) = \text{depth}(u)$

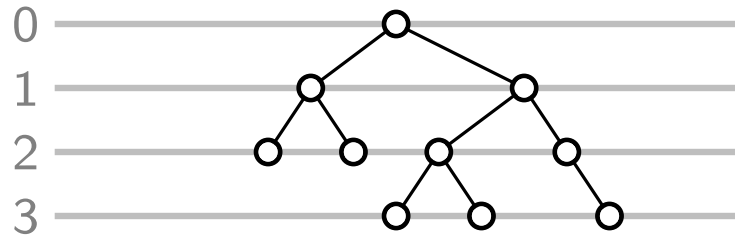

2. Choose x-coordinates:

preorder

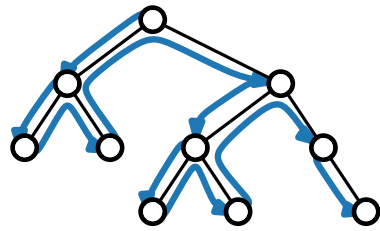

inorder

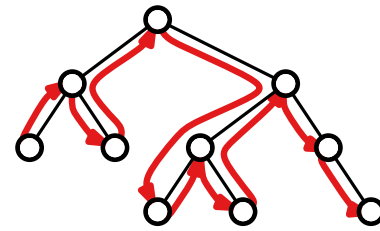

postorder

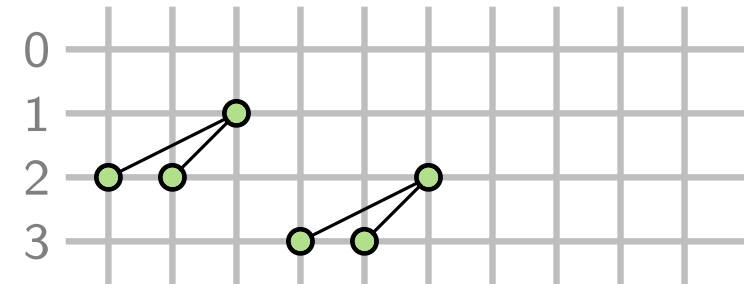
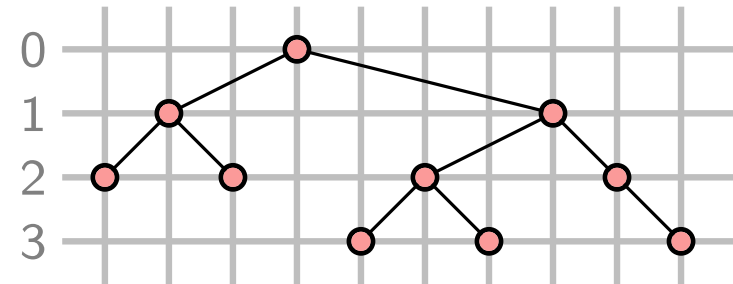
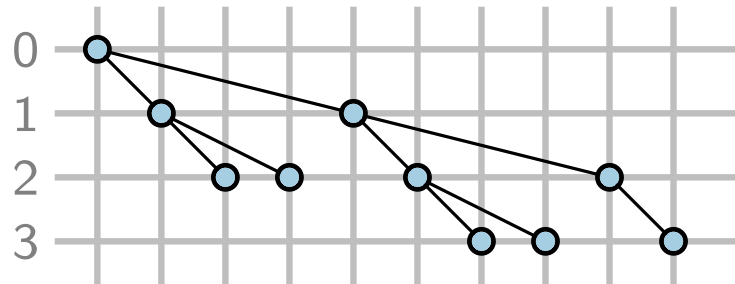
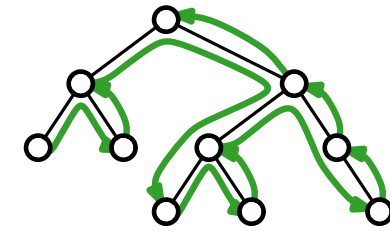

First Grid Layout of Binary Trees

1. Choose y-coordinates: $y(u) = \text{depth}(u)$

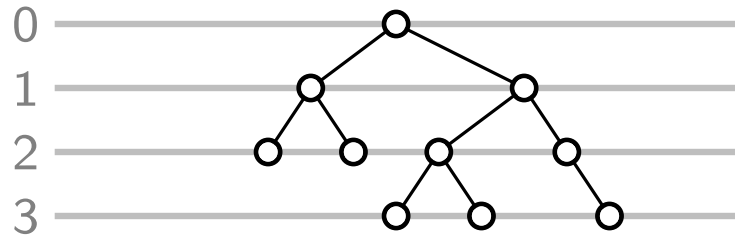

2. Choose x-coordinates:

preorder

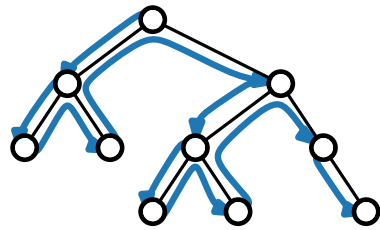

inorder

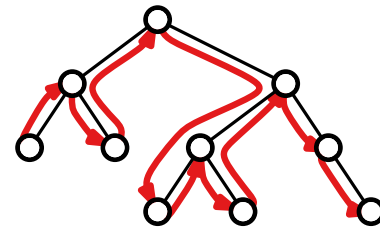

postorder

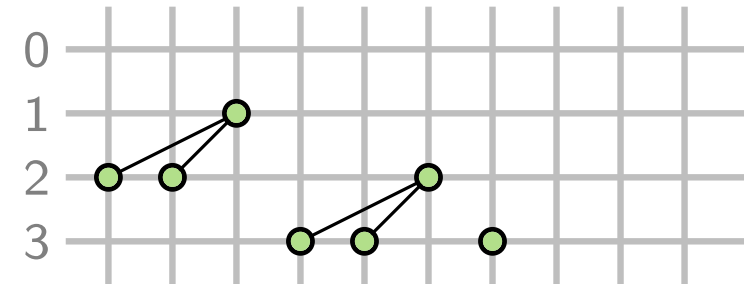
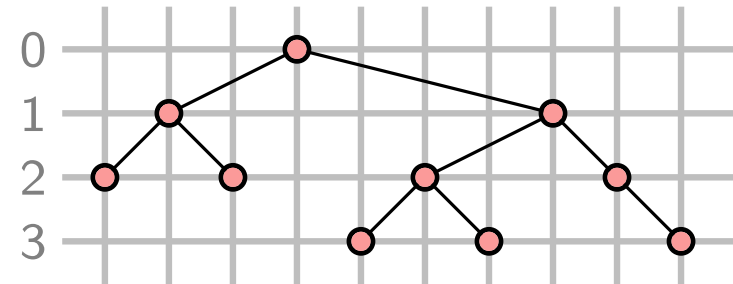
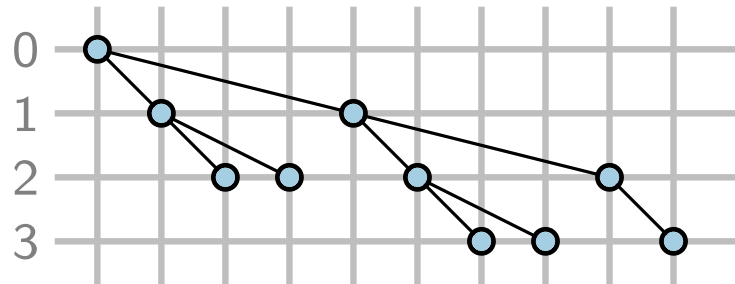
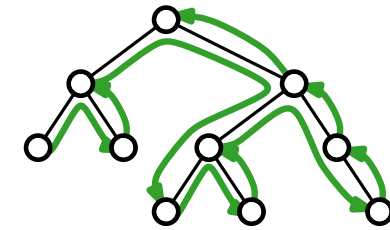

First Grid Layout of Binary Trees

1. Choose y-coordinates: $y(u) = \text{depth}(u)$

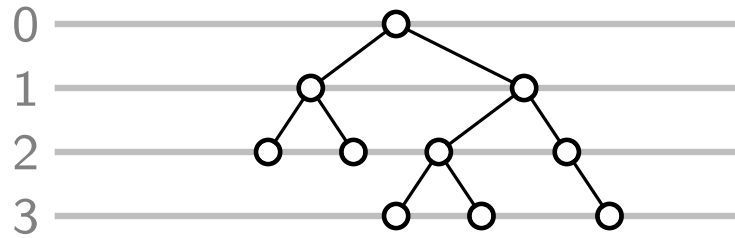

2. Choose x-coordinates:

preorder

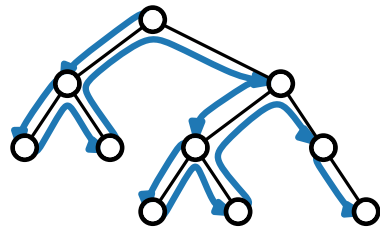

inorder

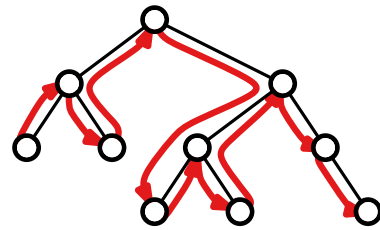

postorder

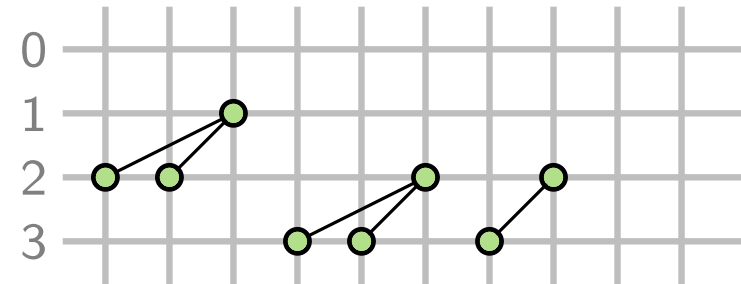
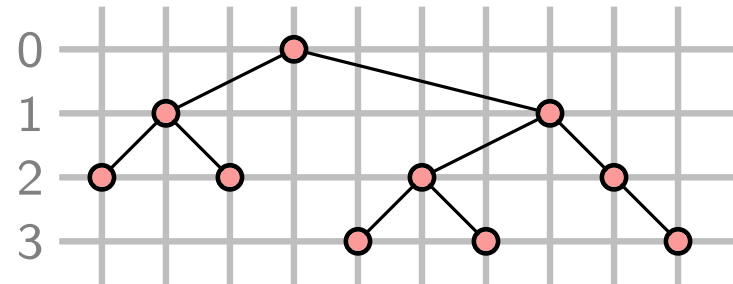
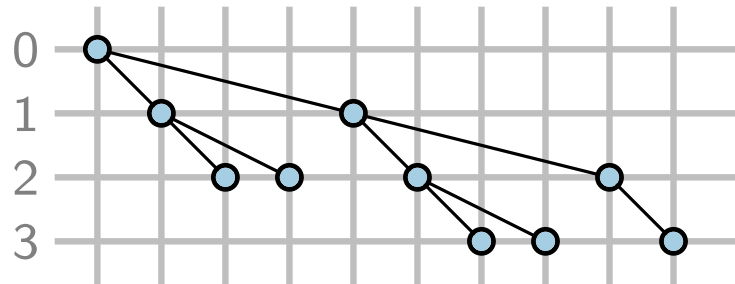
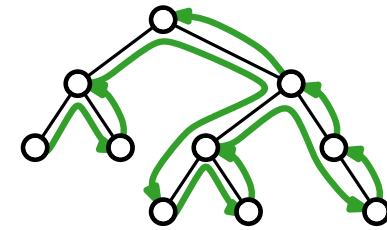

First Grid Layout of Binary Trees

1. Choose y-coordinates: $y(u) = \text{depth}(u)$

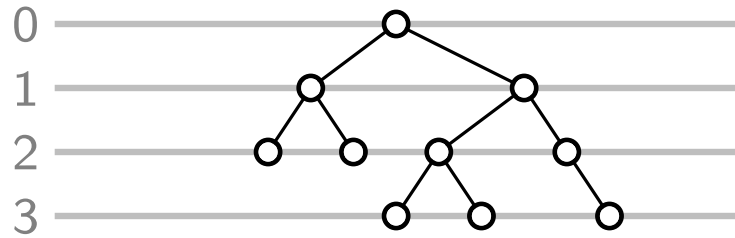

2. Choose x-coordinates:

preorder

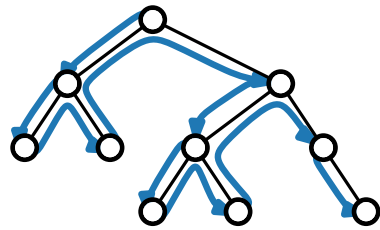

inorder

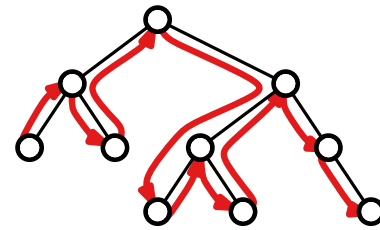

postorder

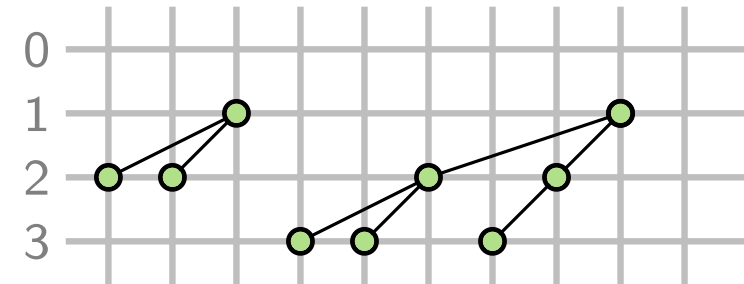
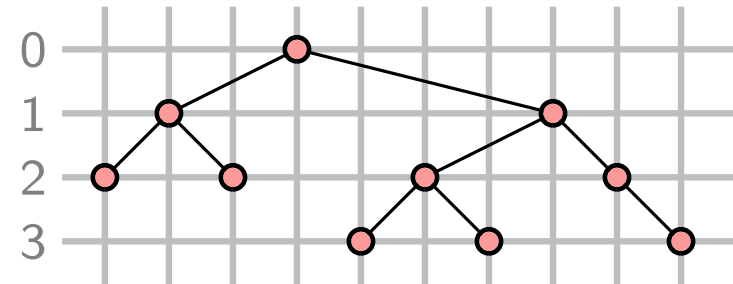
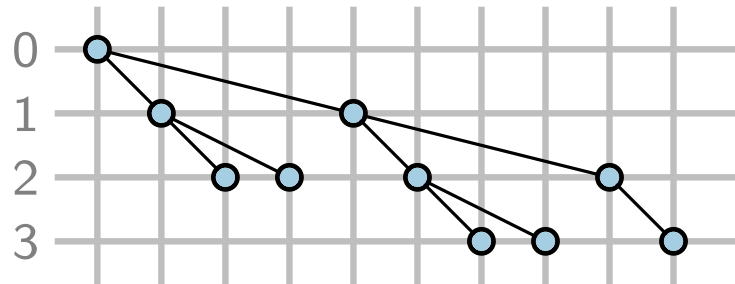
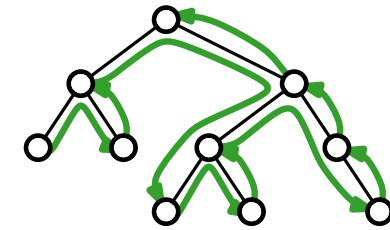

First Grid Layout of Binary Trees

1. Choose y-coordinates: $y(u) = \text{depth}(u)$

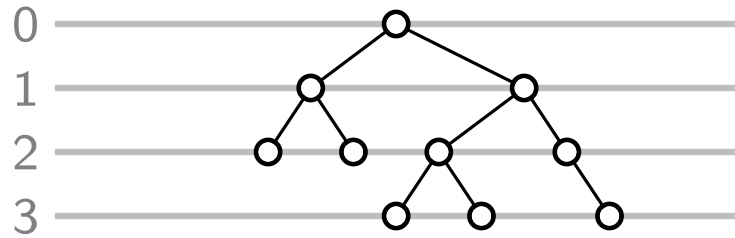

2. Choose x-coordinates:

preorder

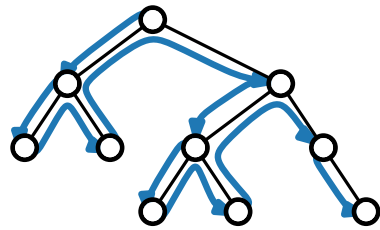

inorder

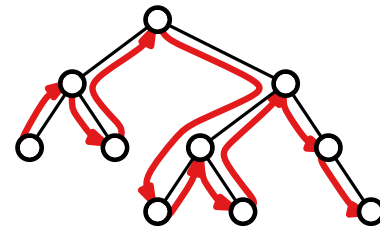

postorder

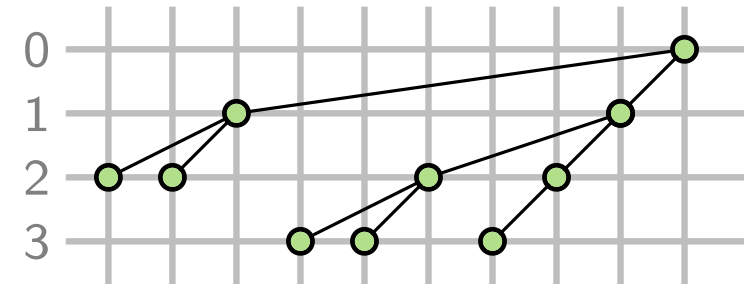
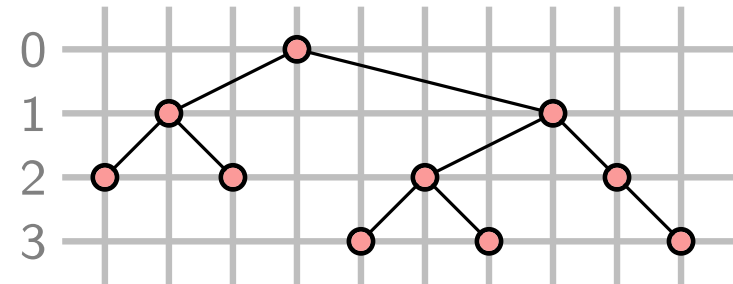
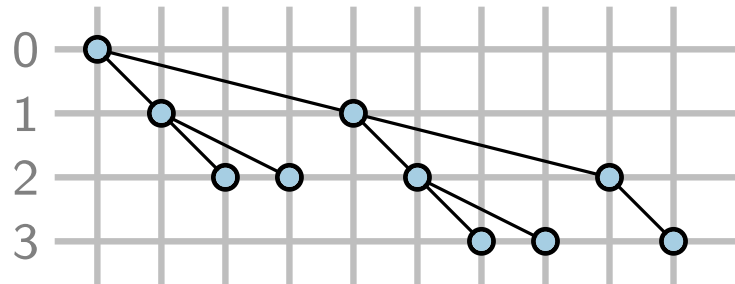
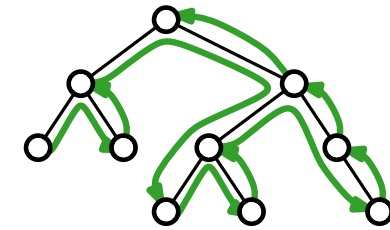

Layered Drawings – Applications

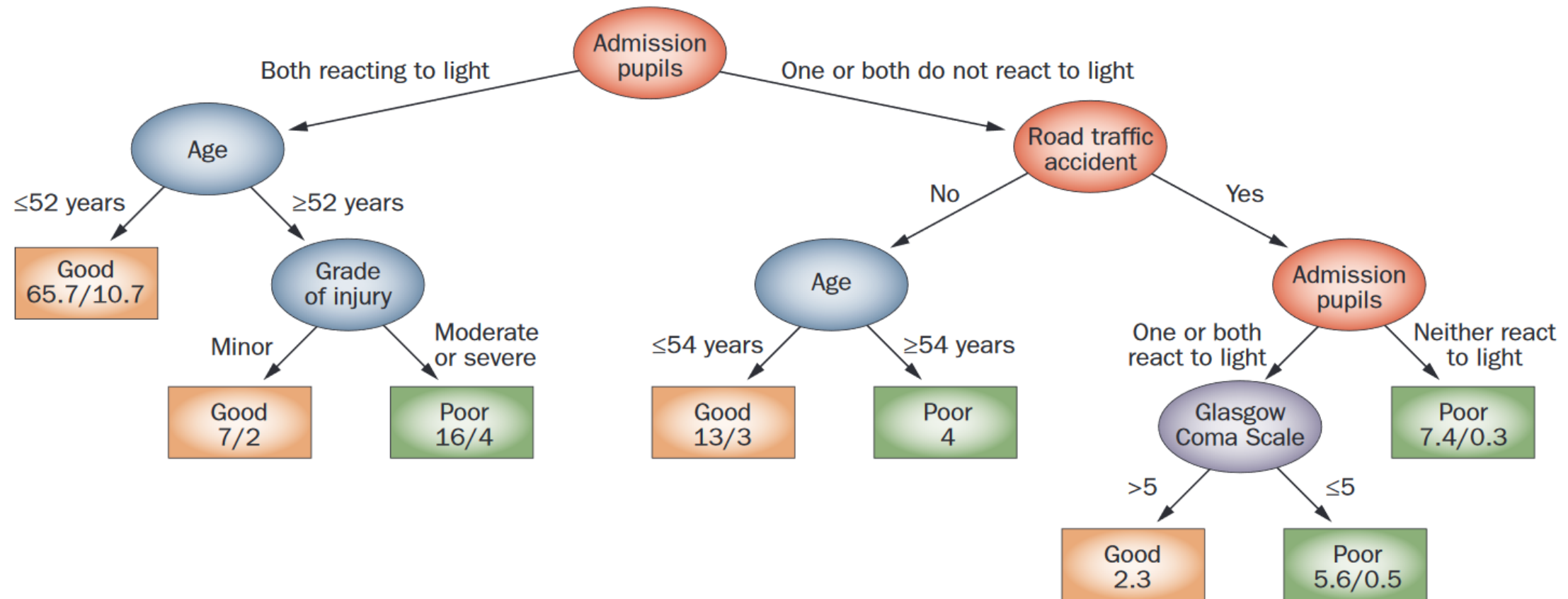

Decision tree for outcome prediction after traumatic brain injury

Source: Nature Reviews Neurology

Layered Drawings – Drawing Style

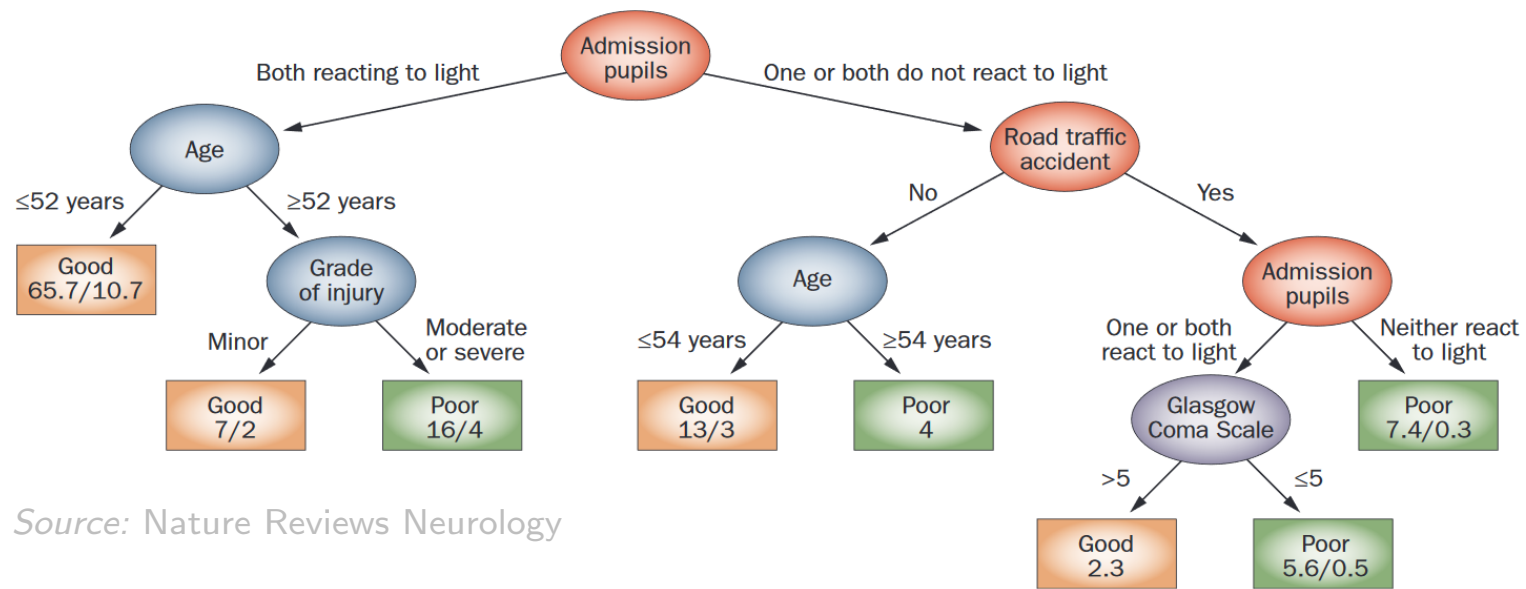

Source: Nature Reviews Neurology

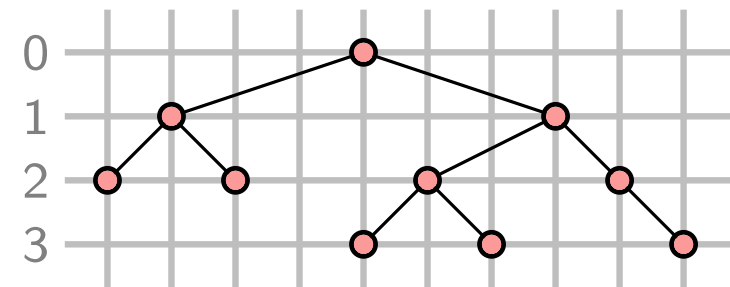

- What are properties of the layout?

Layered Drawings – Drawing Style

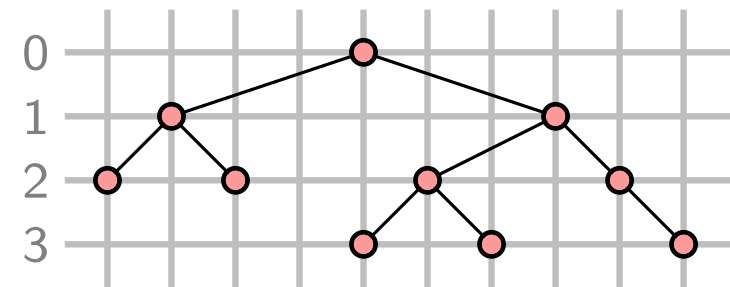
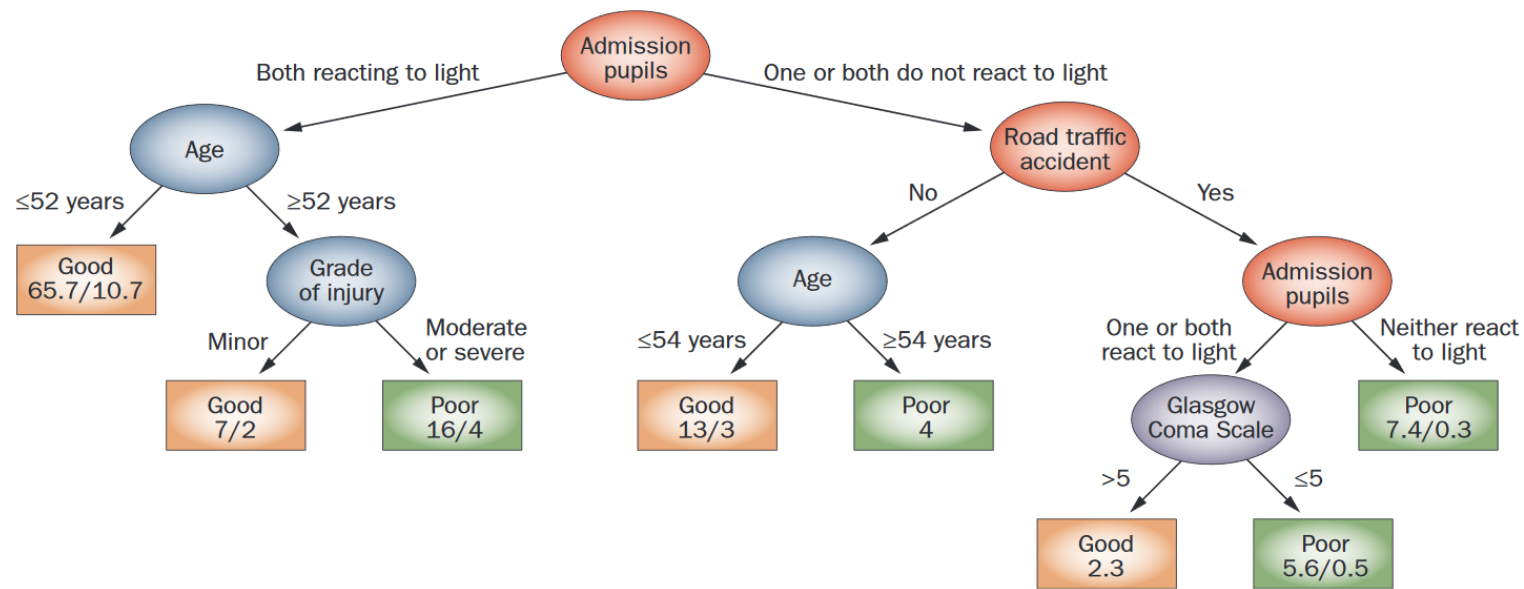

- What are properties of the layout?
- What are the drawing conventions?

Layered Drawings – Drawing Style

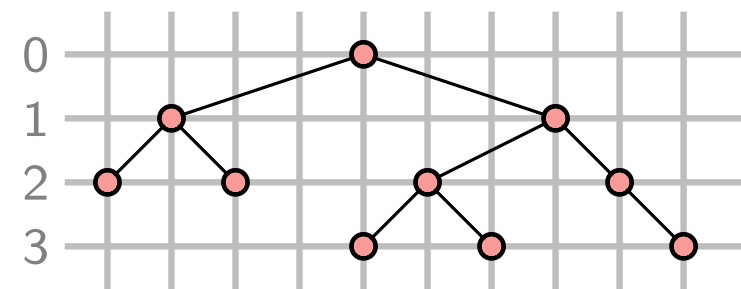
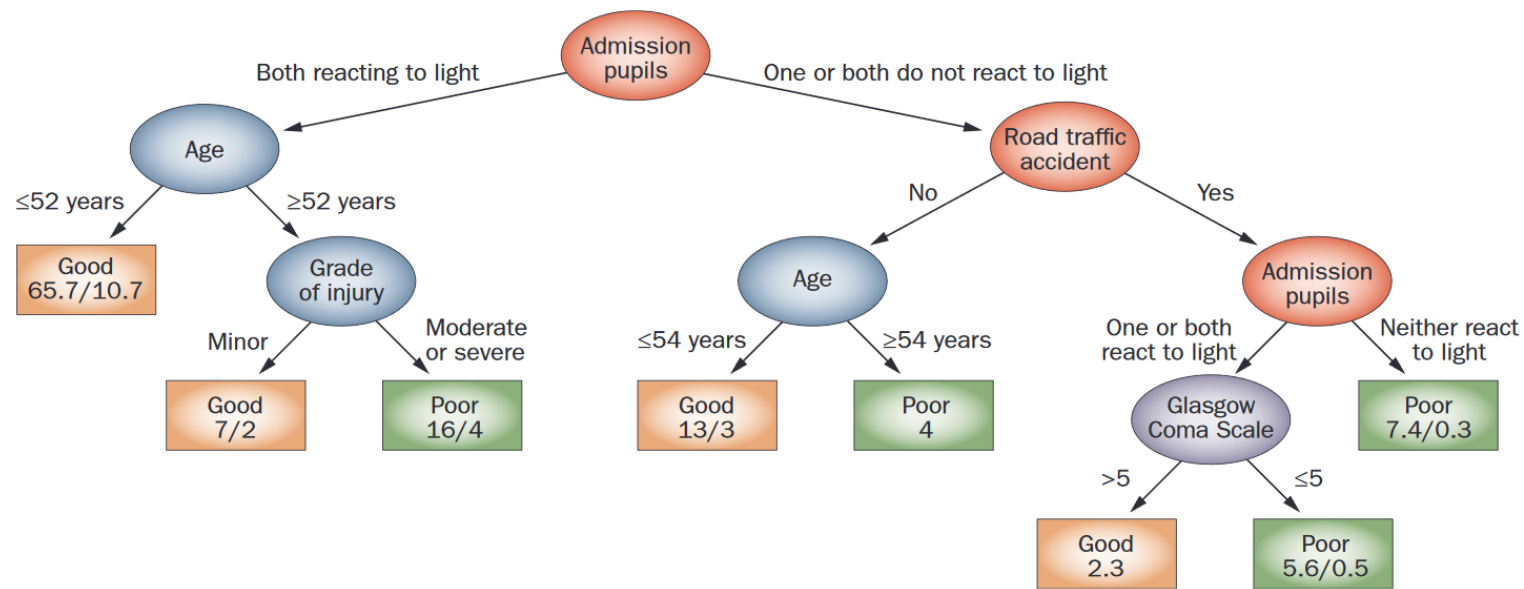

- What are properties of the layout?
- What are the drawing conventions?
- What are aesthetics to optimize?

Layered Drawings – Drawing Style

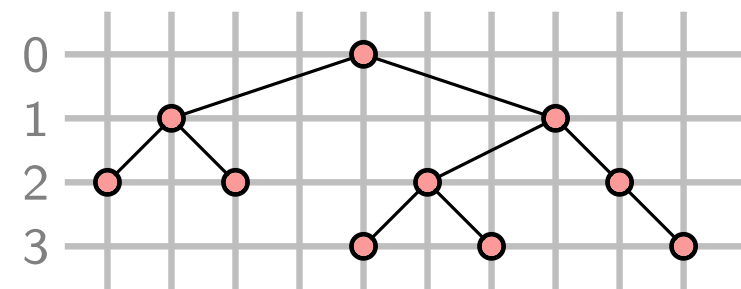
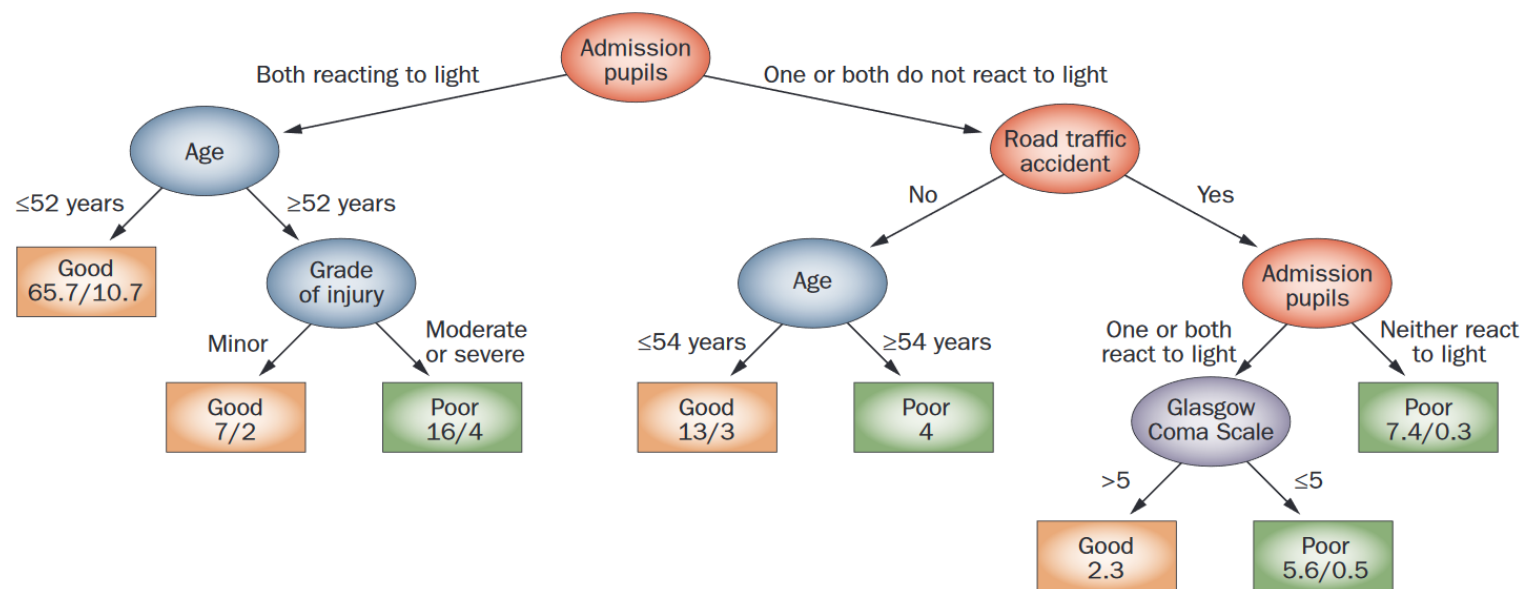

Drawing conventions

- What are properties of the layout?
- What are the drawing conventions?
- What are aesthetics to optimize?

Layered Drawings – Drawing Style

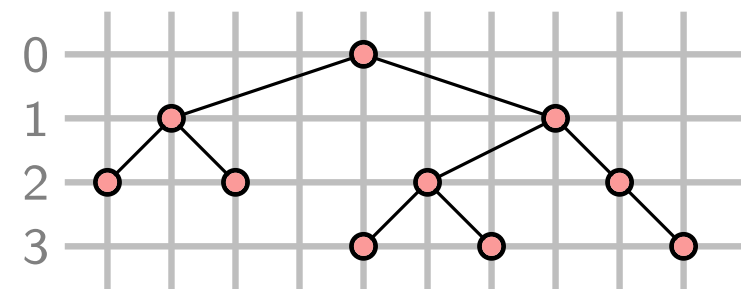
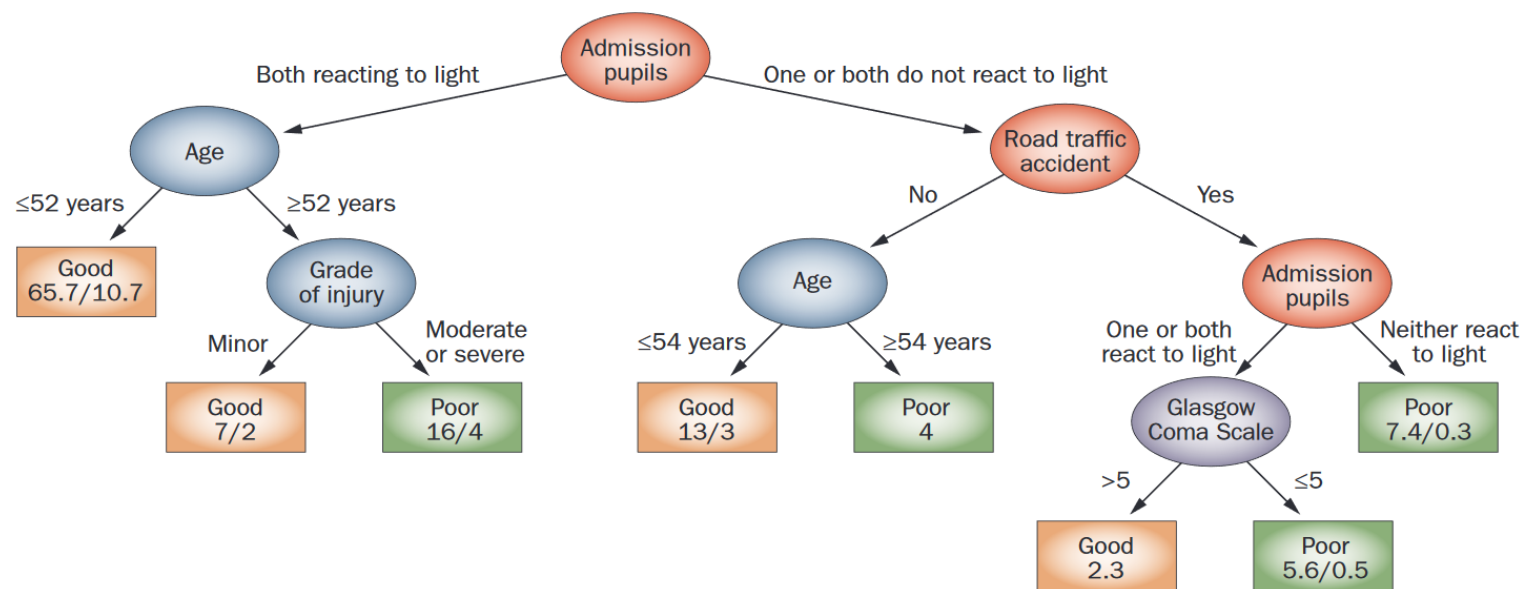

Drawing conventions

- Vertices lie on layers and have integer coordinates

- What are properties of the layout?
- What are the drawing conventions?
- What are aesthetics to optimize?

Layered Drawings – Drawing Style

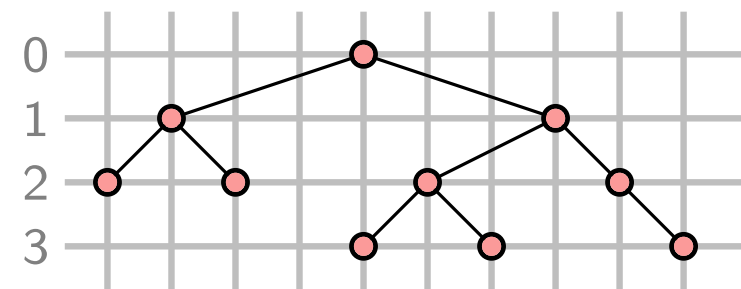
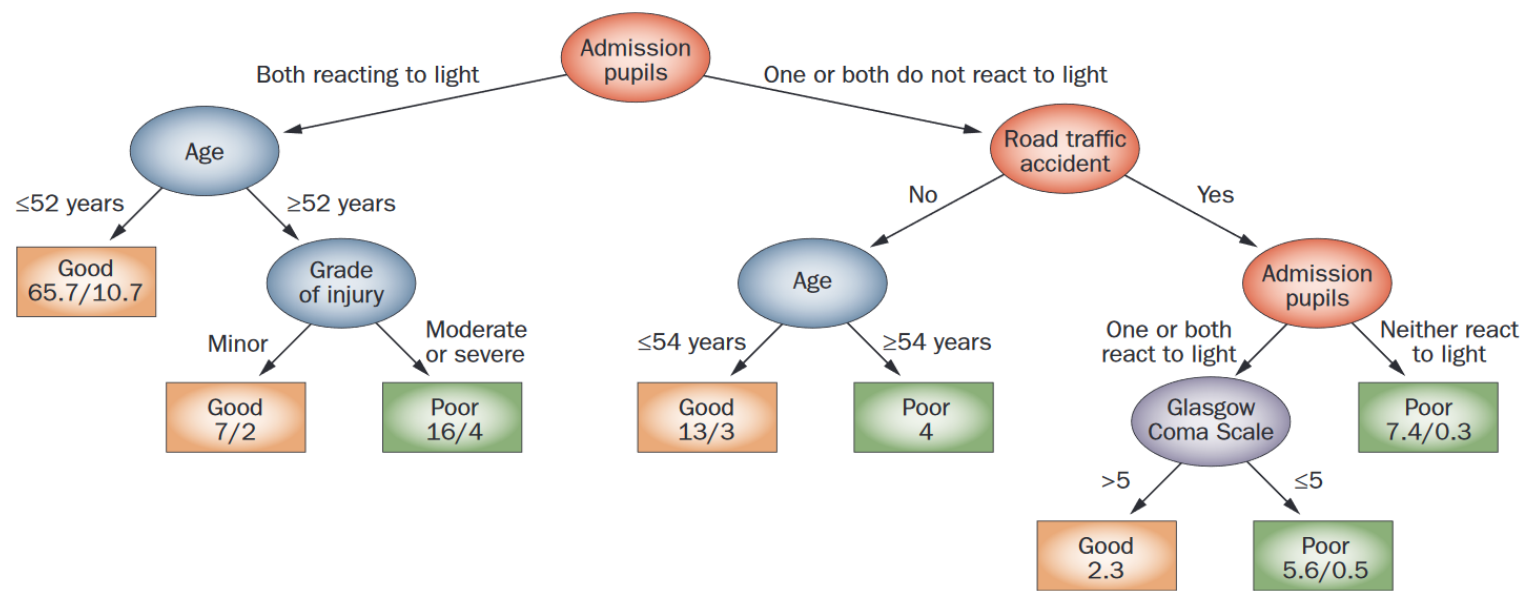

Drawing conventions

- What are properties of the layout?
- What are the drawing conventions?
- What are aesthetics to optimize?

- Vertices lie on layers and have integer coordinates
- Parent centered above children (if there is more than one child)

Layered Drawings – Drawing Style

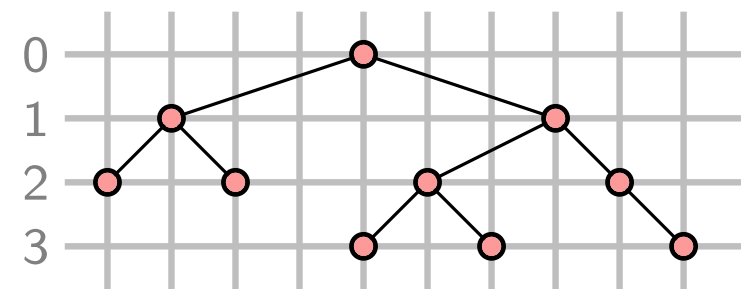
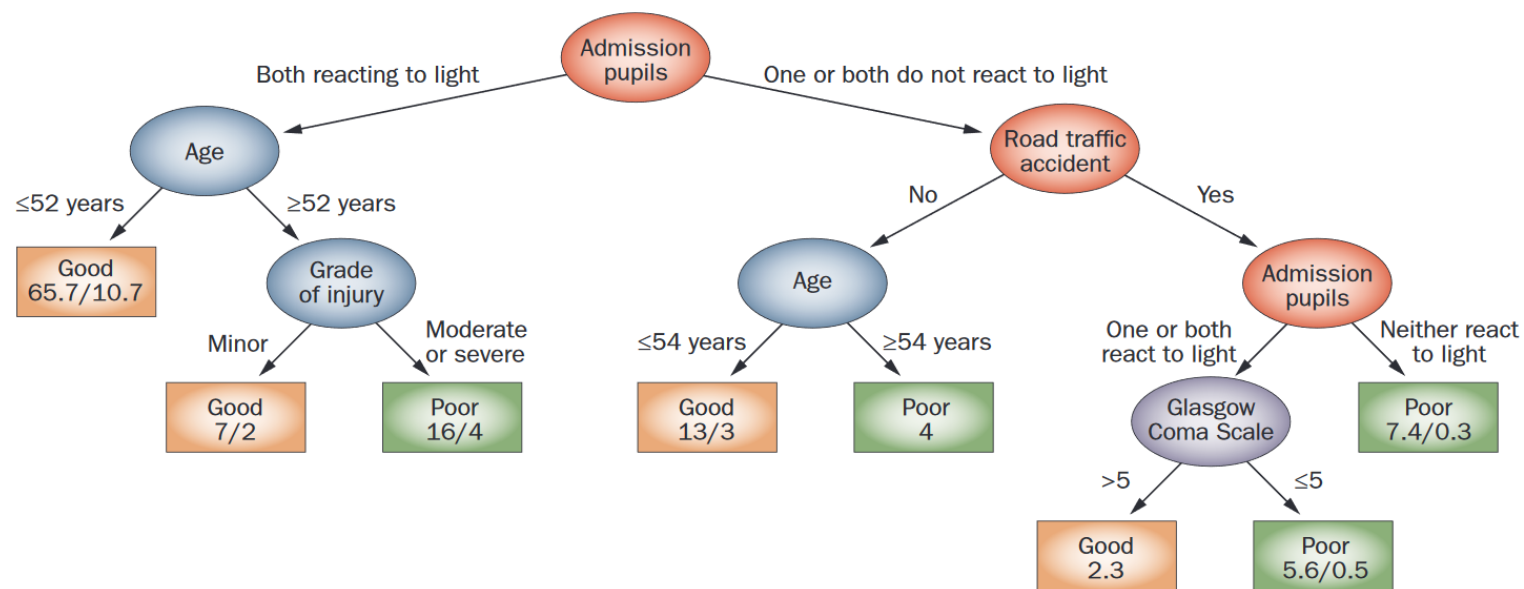

Drawing conventions

- What are properties of the layout?
- What are the drawing conventions?
- What are aesthetics to optimize?

- Vertices lie on layers and have integer coordinates
- Parent centered above children (if there is more than one child)
- Edges are straight-line segments

Layered Drawings – Drawing Style

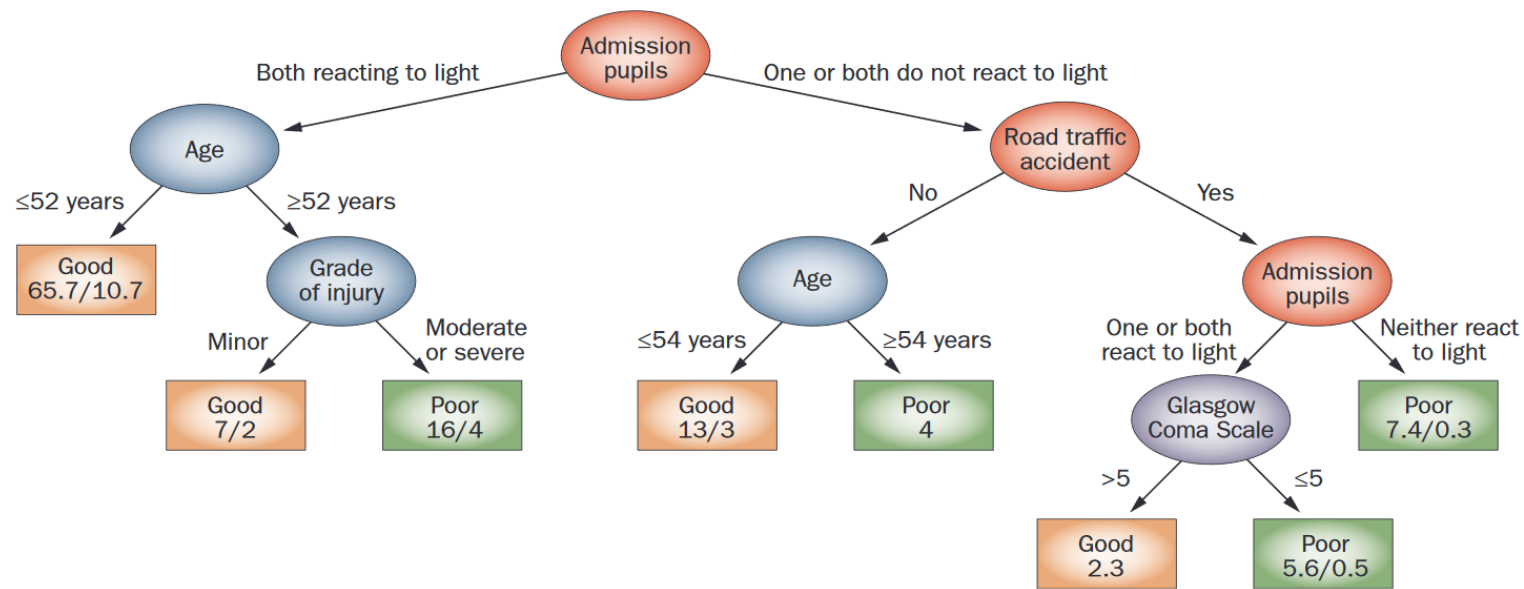
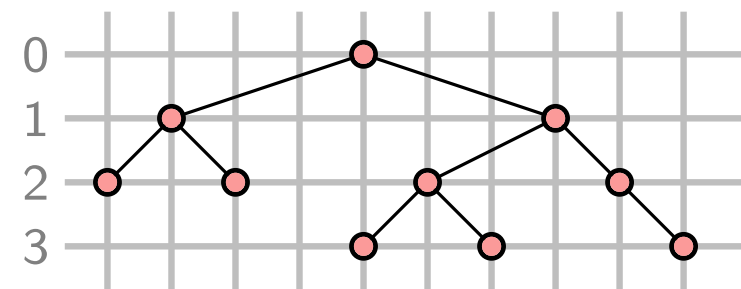

- What are properties of the layout?
- What are the drawing conventions?
- What are aesthetics to optimize?

Drawing conventions

- Vertices lie on layers and have integer coordinates
- Parent centered above children (if there is more than one child)
- Edges are straight-line segments
- Isomorphic subtrees have identical drawings

Layered Drawings – Drawing Style

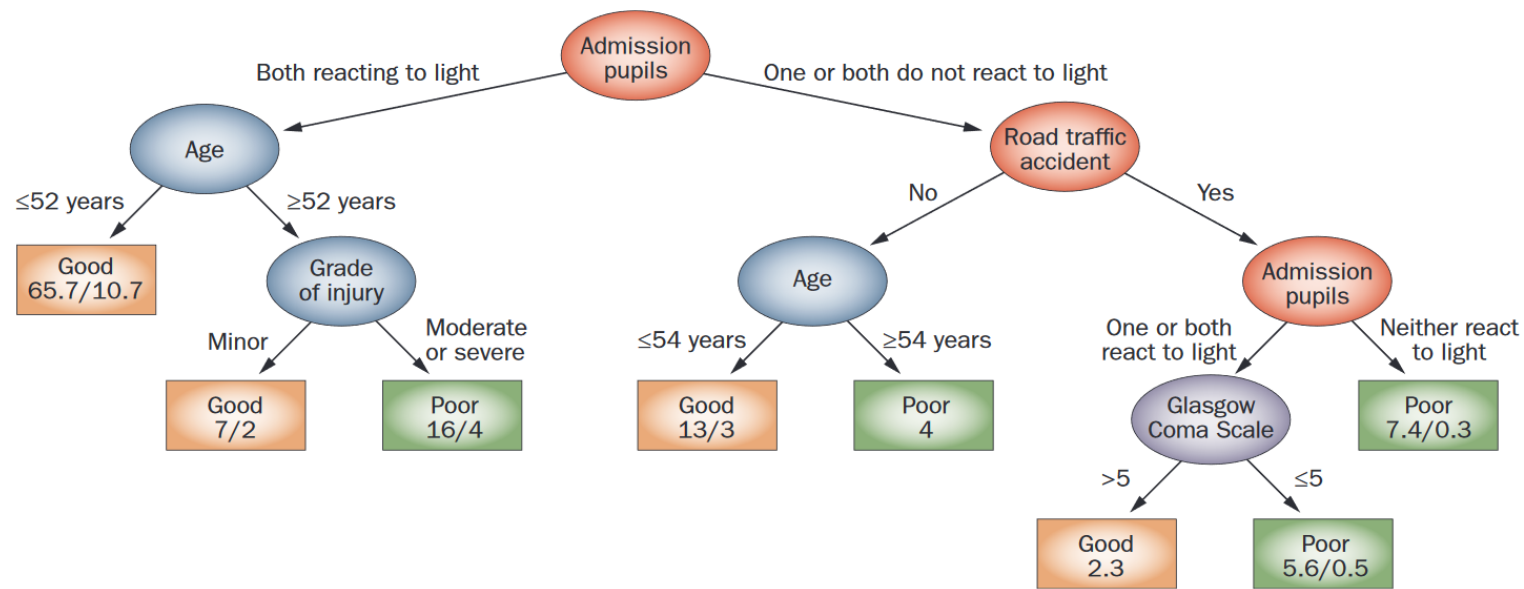
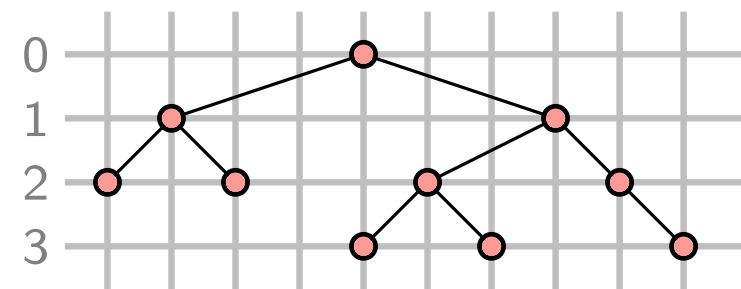

- What are properties of the layout?
- What are the drawing conventions?
- What are aesthetics to optimize?

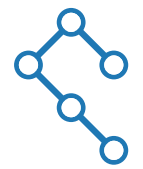

Drawing conventions

- Vertices lie on layers and have integer coordinates
- Parent centered above children (if there is more than one child)
- Edges are straight-line segments
- Isomorphic subtrees have identical drawings

Layered Drawings – Drawing Style

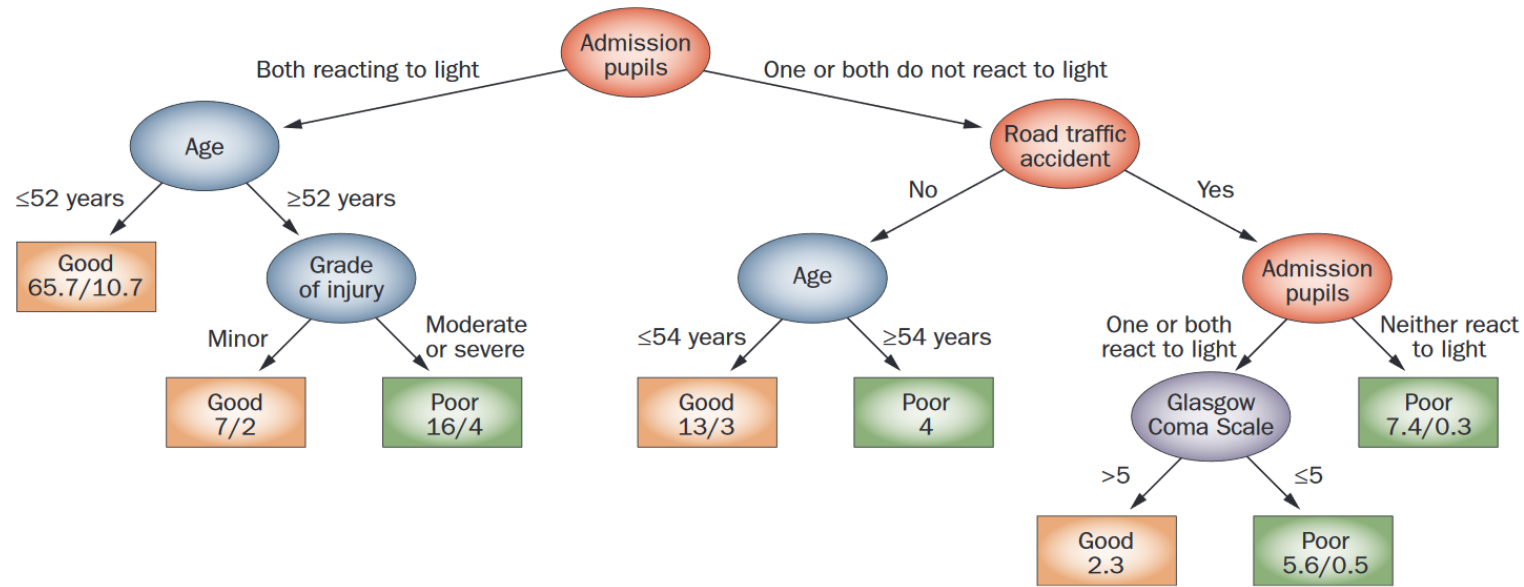

- What are properties of the layout?
- What are the drawing conventions?
- What are aesthetics to optimize?

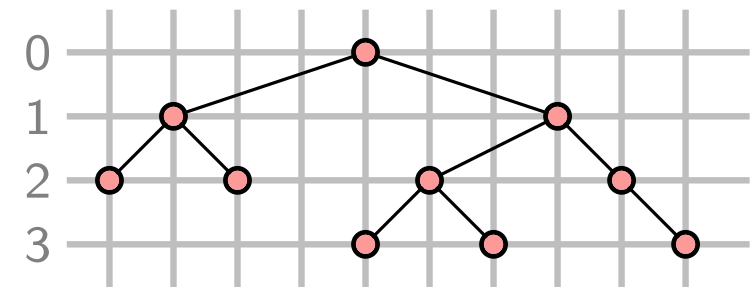
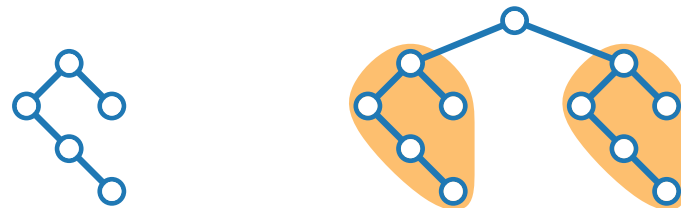

Drawing conventions

- Vertices lie on layers and have integer coordinates
- Parent centered above children (if there is more than one child)
- Edges are straight-line segments
- Isomorphic subtrees have identical drawings

Layered Drawings – Drawing Style

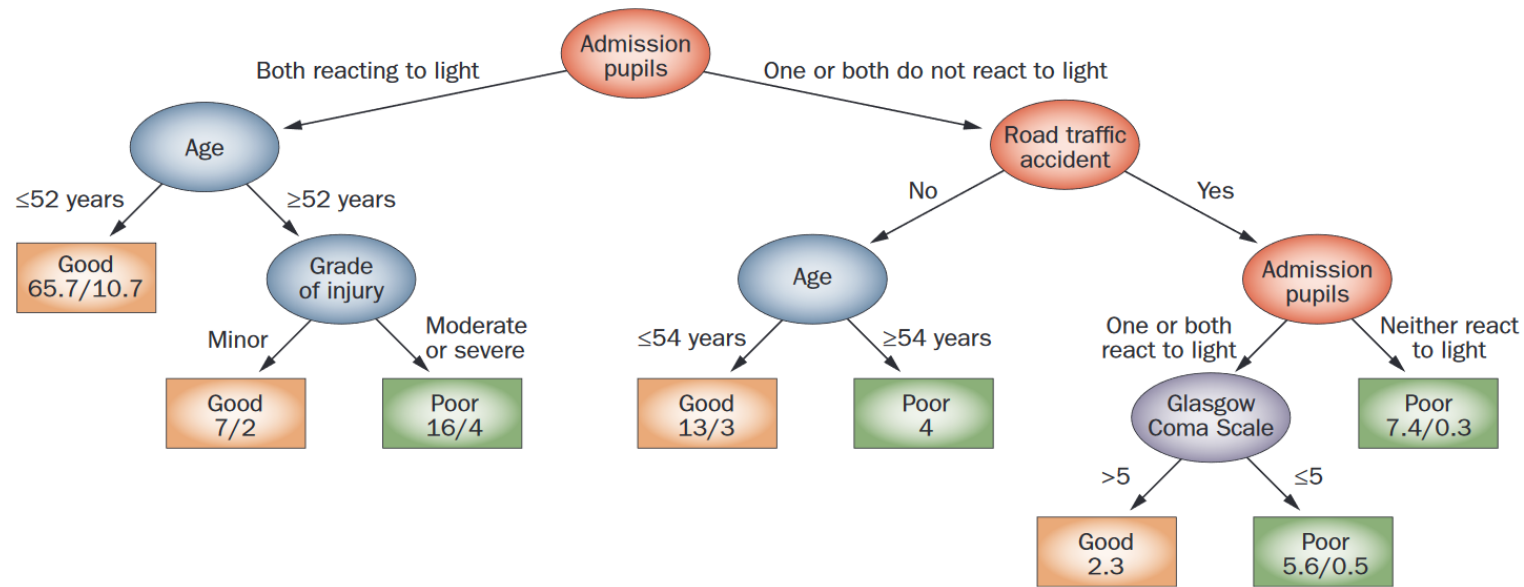

- What are properties of the layout?
- What are the drawing conventions?
- What are aesthetics to optimize?

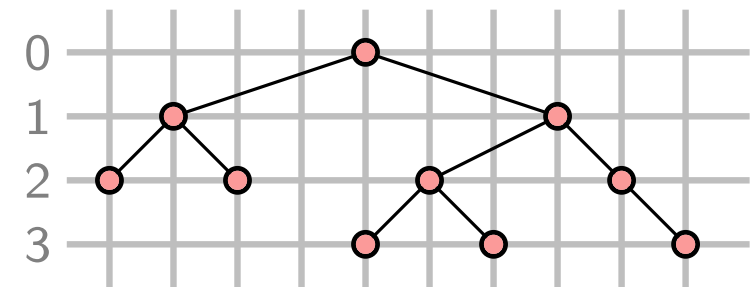
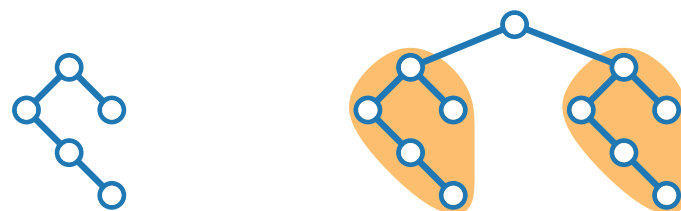

Drawing conventions

- Vertices lie on layers and have integer coordinates
- Parent centered above children (if there is more than one child)
- Edges are straight-line segments
- Isomorphic subtrees have identical drawings

Drawing aesthetics to optimize

Layered Drawings – Drawing Style

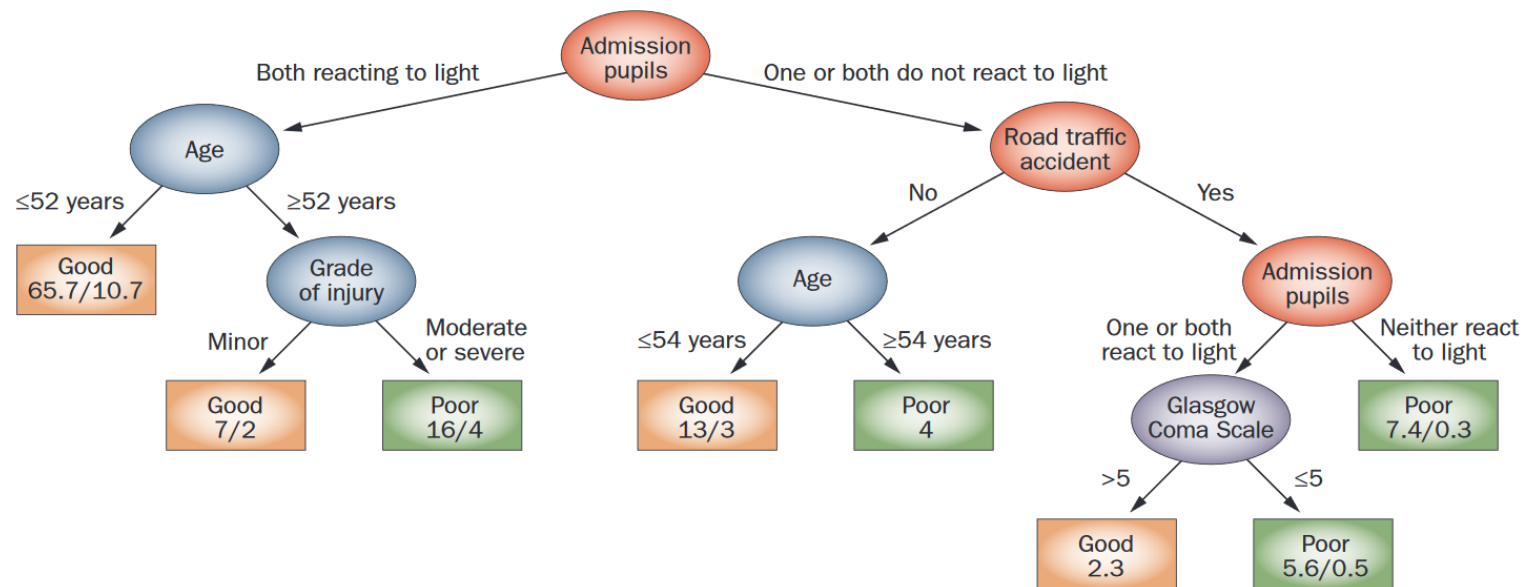

- What are properties of the layout?
- What are the drawing conventions?
- What are aesthetics to optimize?

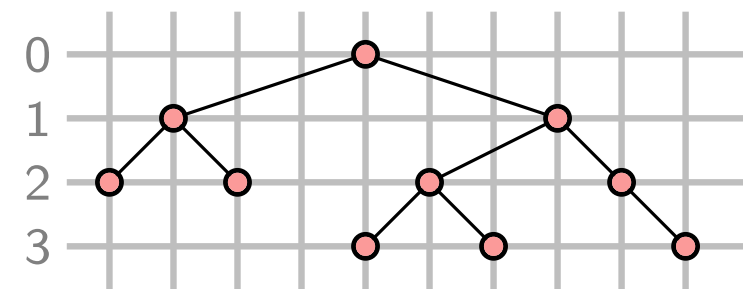
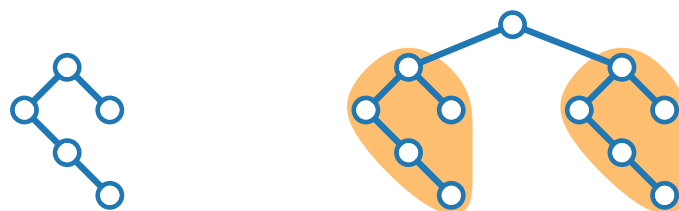

Drawing conventions

- Vertices lie on layers and have integer coordinates
- Parent centered above children (if there is more than one child)
- Edges are straight-line segments
- Isomorphic subtrees have identical drawings

Drawing aesthetics to optimize

- Area

Layered Drawings – Drawing Style

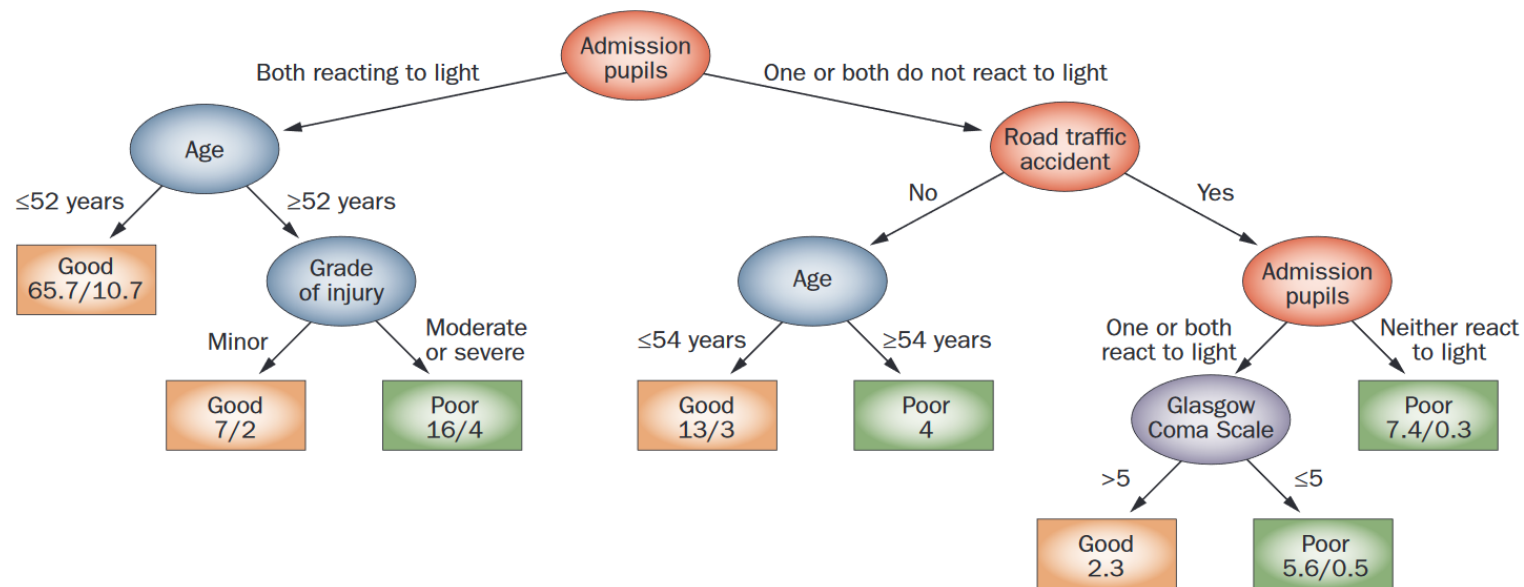

- What are properties of the layout?
- What are the drawing conventions?
- What are aesthetics to optimize?

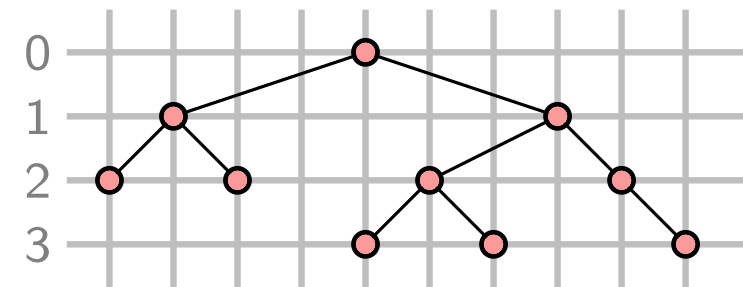
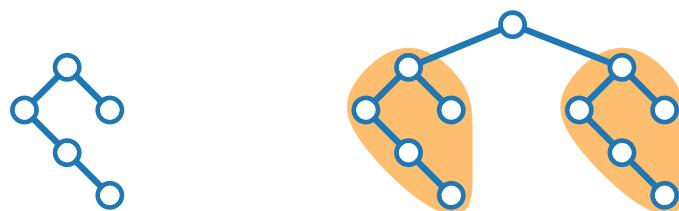

Drawing conventions

- Vertices lie on layers and have integer coordinates
- Parent centered above children (if there is more than one child)
- Edges are straight-line segments
- Isomorphic subtrees have identical drawings

Drawing aesthetics to optimize

- Area
- Symmetries

Layered Drawings – Algorithm

Input: A binary tree T

Output: A layered drawing of T

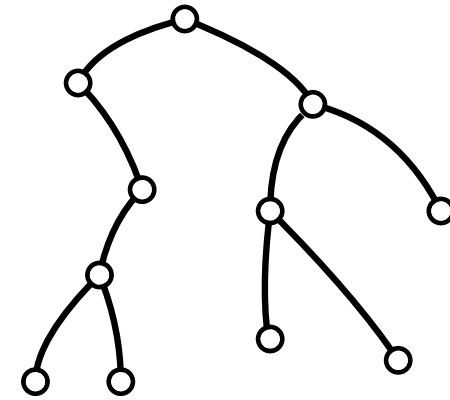

Layered Drawings – Algorithm

Input: A binary tree T

Output: A layered drawing of T

Base case:

Divide:

Conquer:

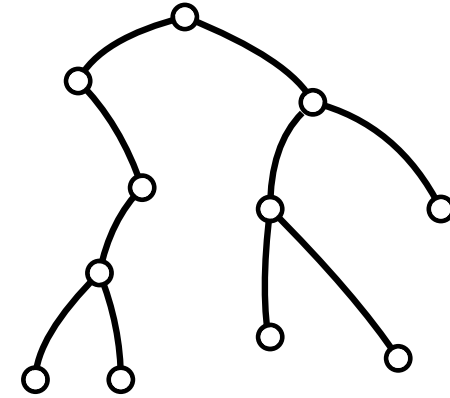

Layered Drawings – Algorithm

Input: A binary tree T

Output: A layered drawing of T

Base case: A single vertex \circ

Divide:

Conquer:

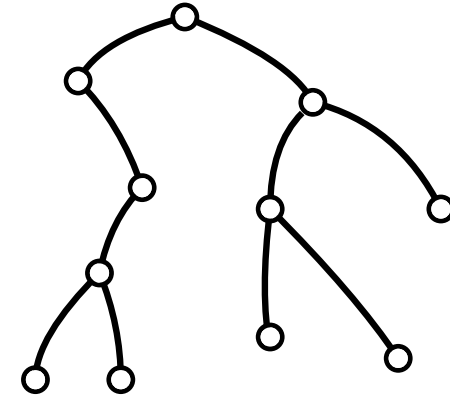

Layered Drawings – Algorithm

Input: A binary tree T

Output: A layered drawing of T

Base case: A single vertex \circ

Divide: Recursively apply the algorithm to draw the left and right subtrees

Conquer:

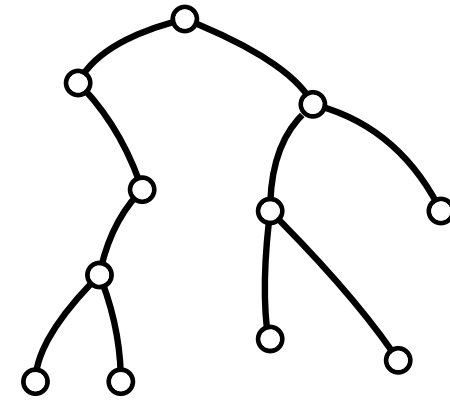

Layered Drawings – Algorithm

Input: A binary tree T

Output: A layered drawing of T

Base case: A single vertex 

Divide: Recursively apply the algorithm to draw the left and right subtrees

Conquer:

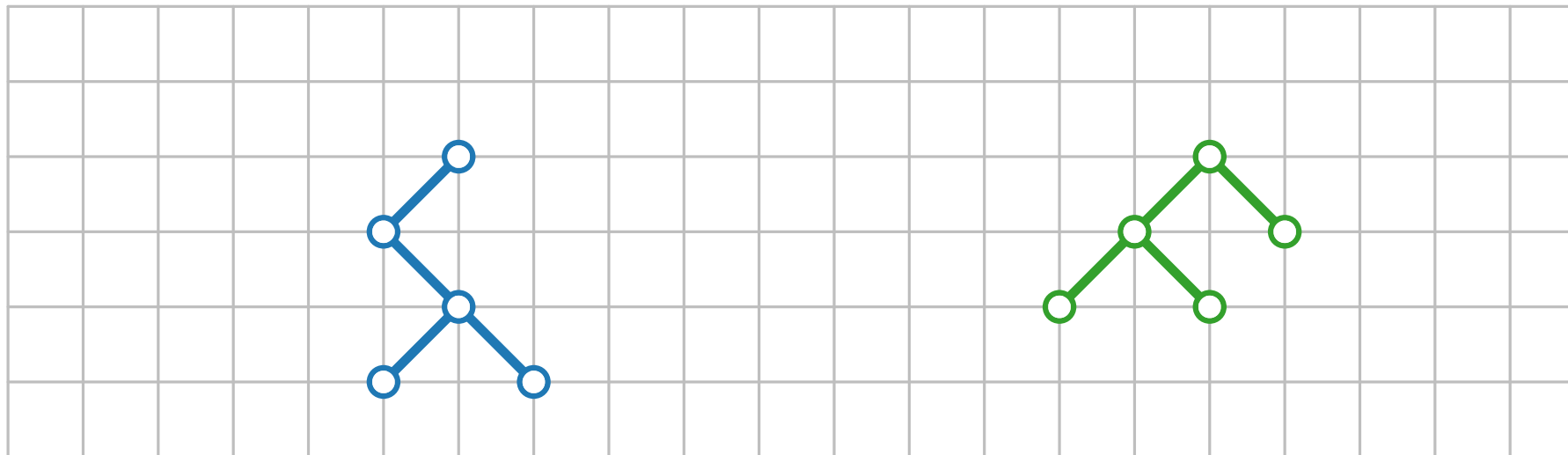
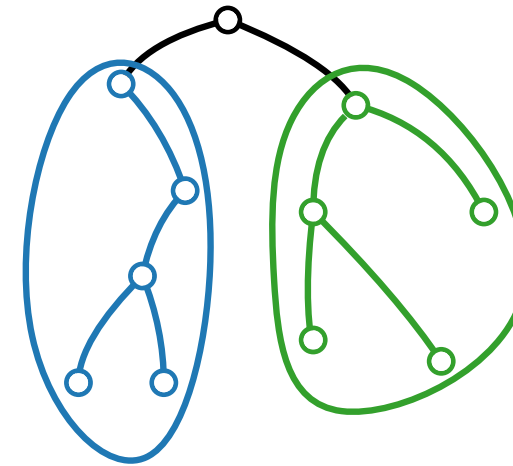

Layered Drawings – Algorithm

Input: A binary tree T

Output: A layered drawing of T

Base case: A single vertex 

Divide: Recursively apply the algorithm to draw the left and right subtrees

Conquer:

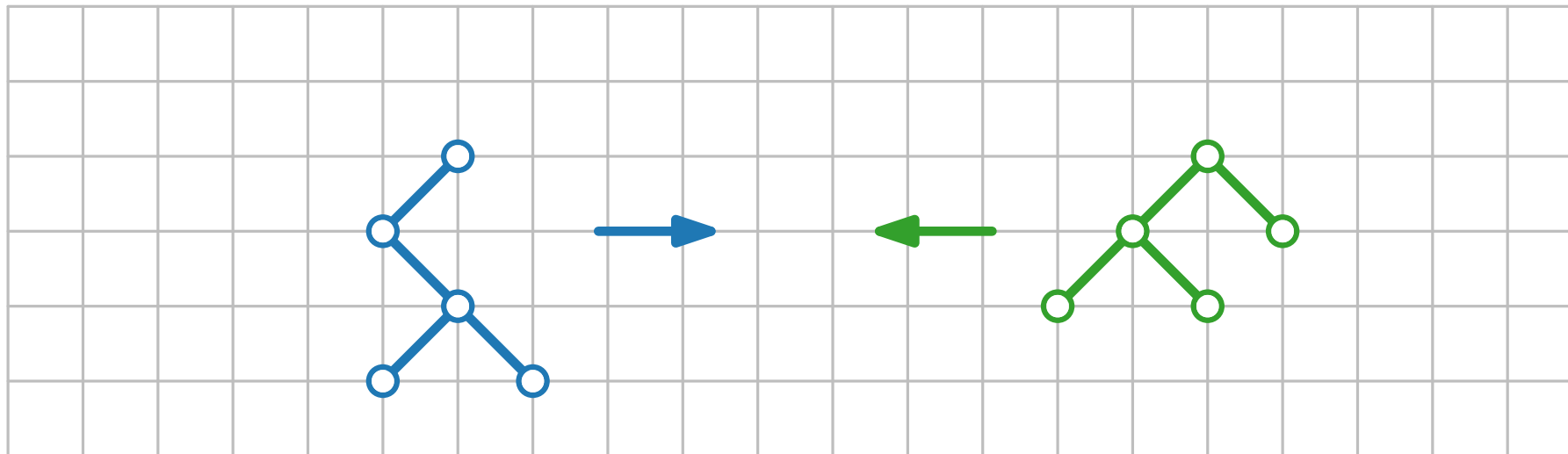
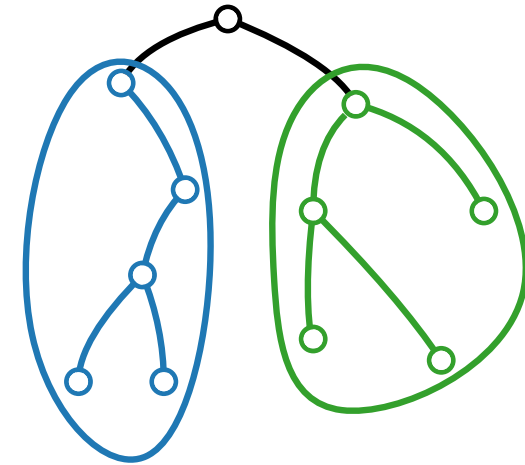

Layered Drawings – Algorithm

Input: A binary tree T

Output: A layered drawing of T

Base case: A single vertex \circ

Divide: Recursively apply the algorithm to draw the left and right subtrees

Conquer:

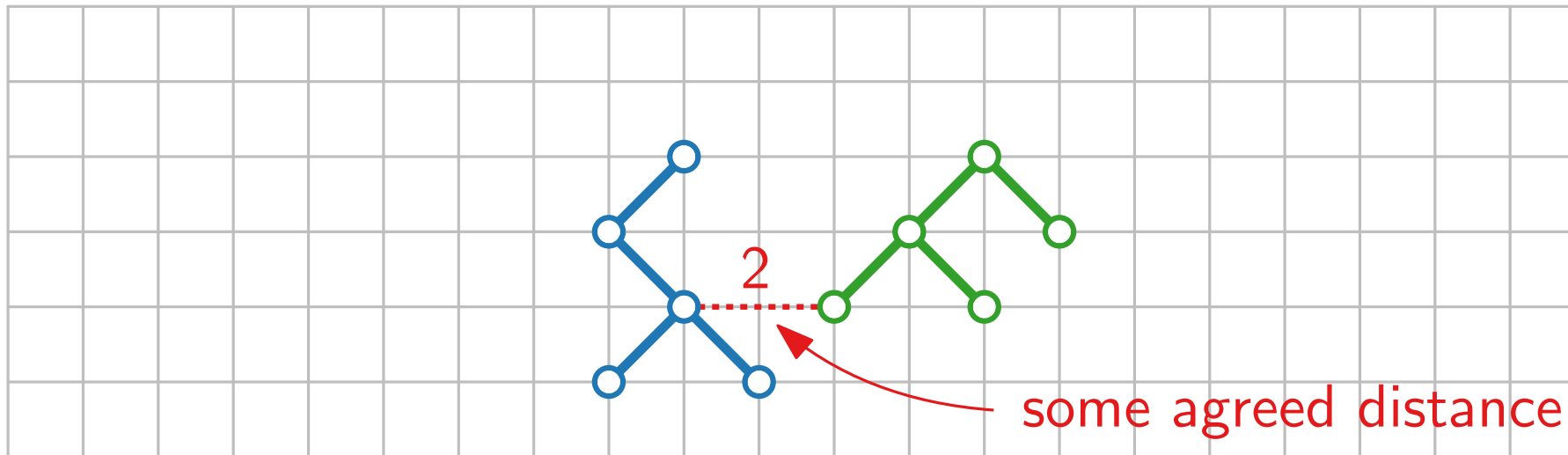
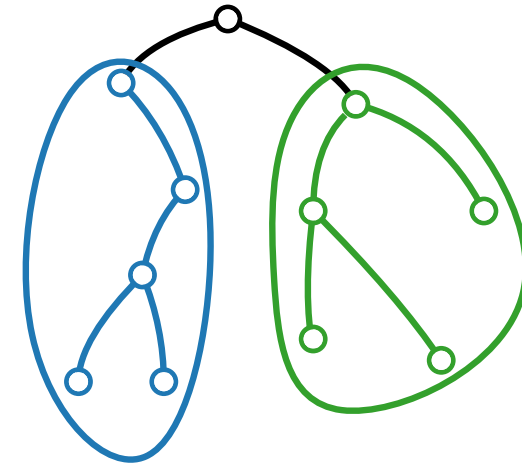

Layered Drawings – Algorithm

Input: A binary tree T

Output: A layered drawing of T

Base case: A single vertex \circ

Divide: Recursively apply the algorithm to draw the left and right subtrees

Conquer:

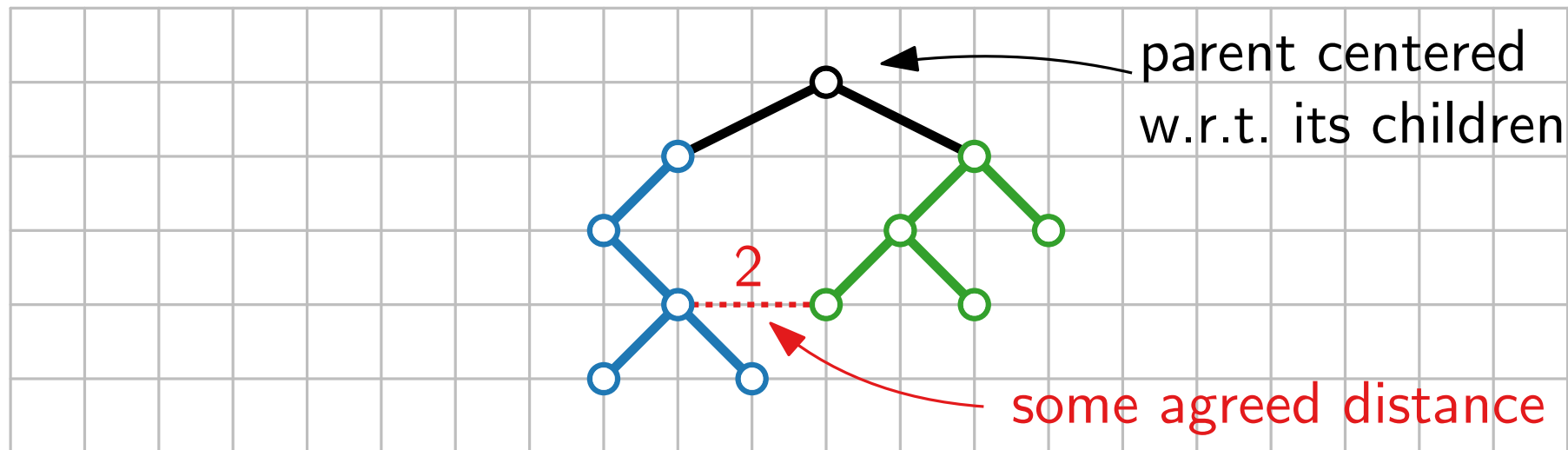
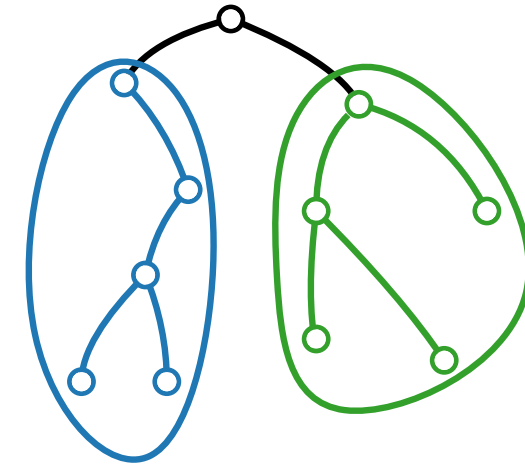

Layered Drawings – Algorithm

Input: A binary tree T

Output: A layered drawing of T

Base case: A single vertex \circ

Divide: Recursively apply the algorithm to draw the left and right subtrees

Conquer:

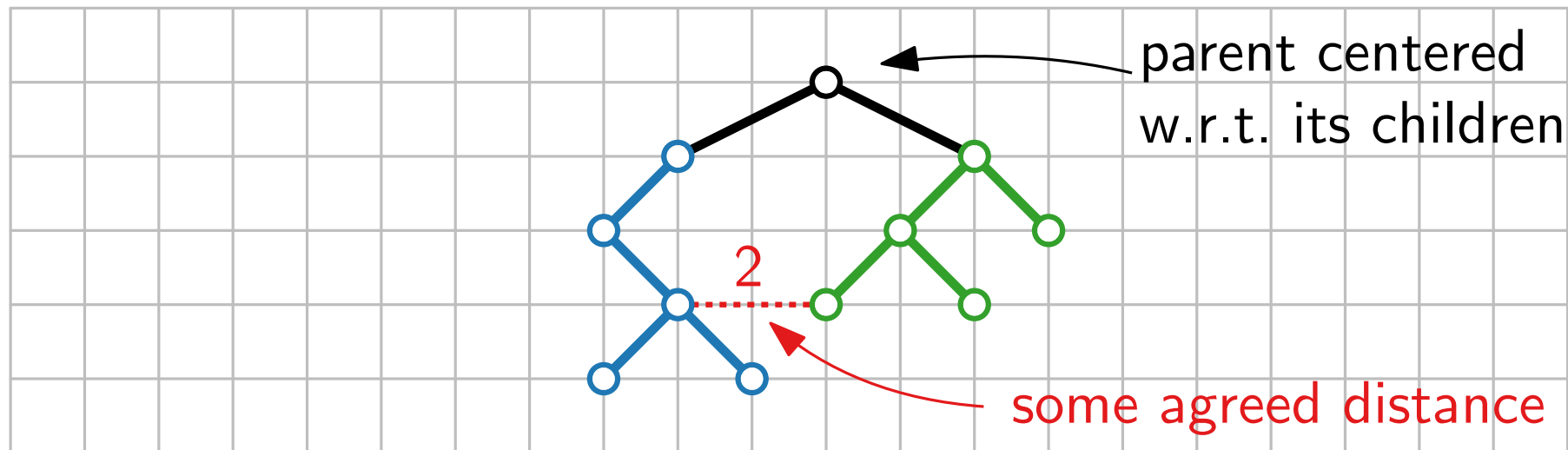
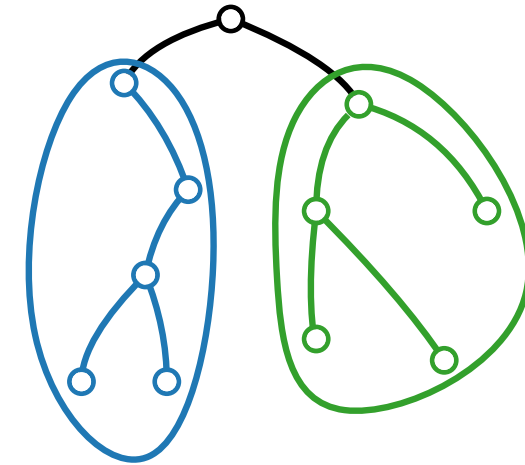

sometimes **3** apart for grid drawing!

Layered Drawings – Algorithm Details

Phase 1 – postorder traversal:

- For each vertex v , compute horizontal displacement of left child v_l and right child v_r .

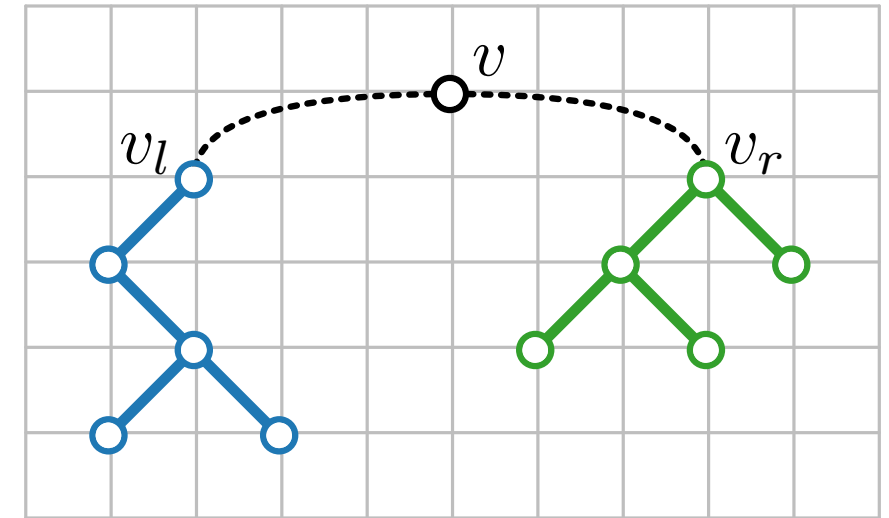

Layered Drawings – Algorithm Details

Phase 1 – postorder traversal:

- For each vertex v , compute horizontal displacement of left child v_l and right child v_r .

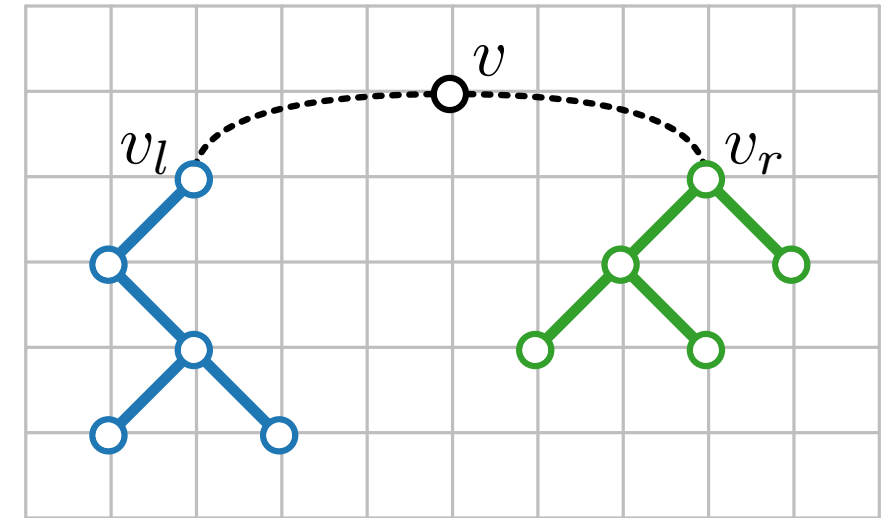

Phase 2 – preorder traversal:

- Compute x- and y-coordinates

Layered Drawings – Algorithm Details

Phase 1 – postorder traversal:

- For each vertex v , compute horizontal displacement of left child v_l and right child v_r .

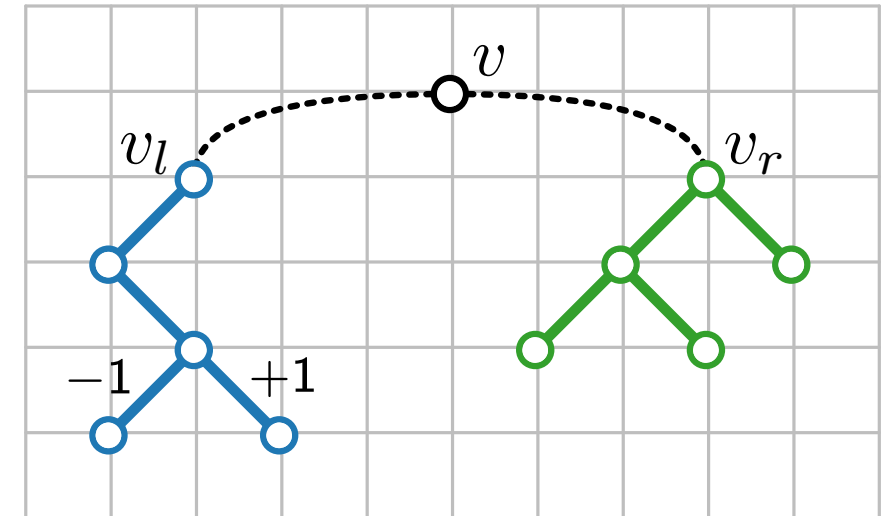

Phase 2 – preorder traversal:

- Compute x- and y-coordinates

Layered Drawings – Algorithm Details

Phase 1 – postorder traversal:

- For each vertex v , compute horizontal displacement of left child v_l and right child v_r .

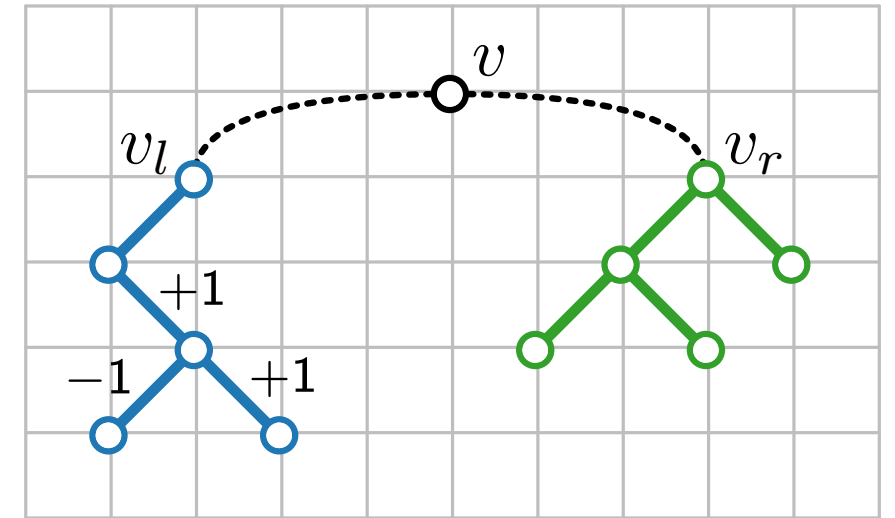

Phase 2 – preorder traversal:

- Compute x- and y-coordinates

Layered Drawings – Algorithm Details

Phase 1 – postorder traversal:

- For each vertex v , compute horizontal displacement of left child v_l and right child v_r .

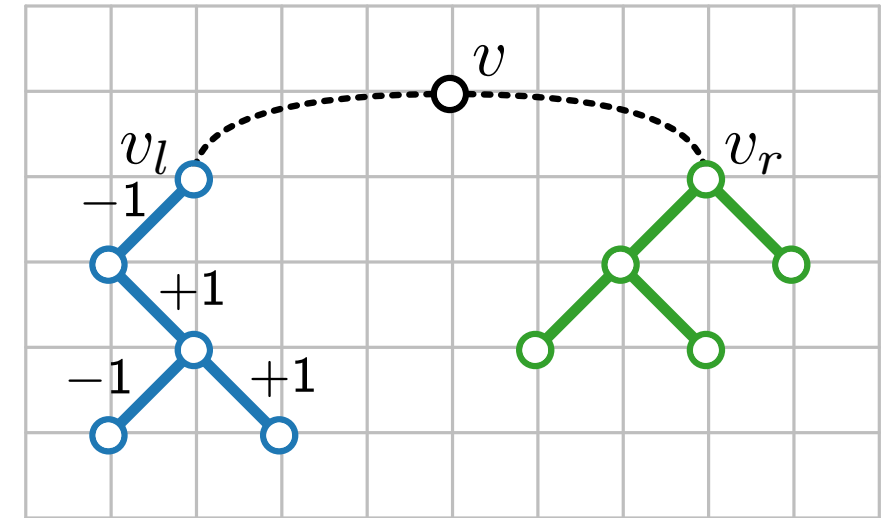

Phase 2 – preorder traversal:

- Compute x- and y-coordinates

Layered Drawings – Algorithm Details

Phase 1 – postorder traversal:

- For each vertex v , compute horizontal displacement of left child v_l and right child v_r .

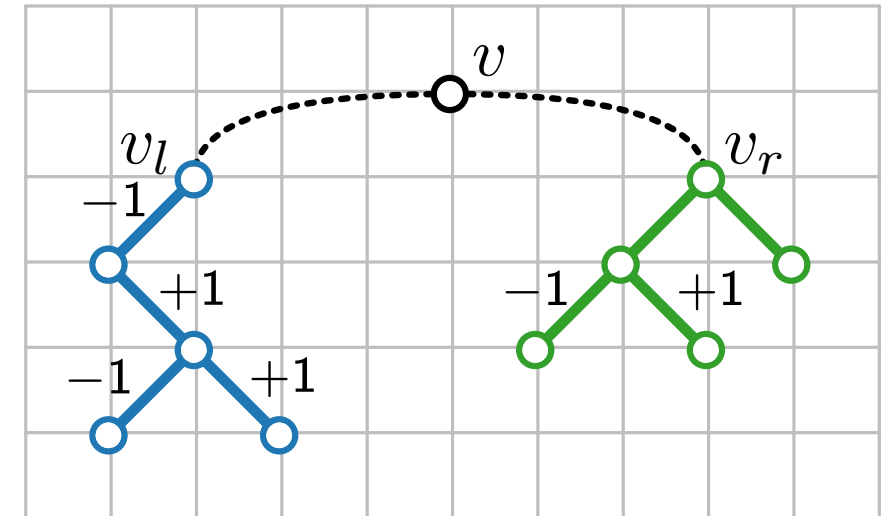

Phase 2 – preorder traversal:

- Compute x- and y-coordinates

Layered Drawings – Algorithm Details

Phase 1 – postorder traversal:

- For each vertex v , compute horizontal displacement of left child v_l and right child v_r .

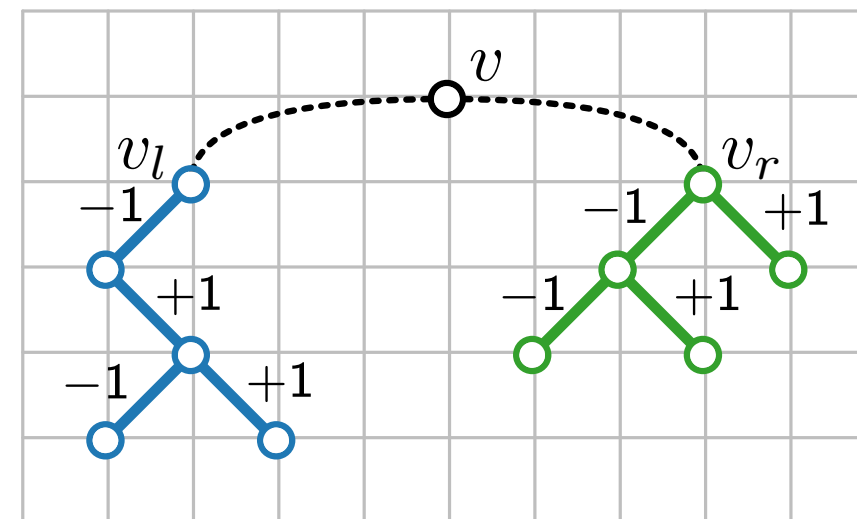

Phase 2 – preorder traversal:

- Compute x- and y-coordinates

Layered Drawings – Algorithm Details

Phase 1 – postorder traversal:

- For each vertex v , compute horizontal displacement of left child v_l and right child v_r .

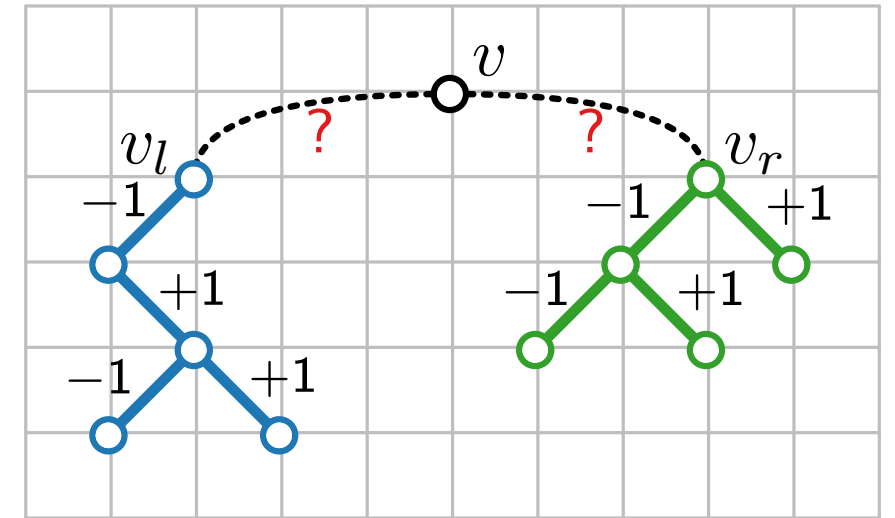

Phase 2 – preorder traversal:

- Compute x- and y-coordinates

Layered Drawings – Algorithm Details

Phase 1 – postorder traversal:

- For each vertex v , compute horizontal displacement of left child v_l and right child v_r .
- At every vertex v store left and right **contour** of subtree $T(v)$.
- A contour is a linked list of vertex coordinates/offsets.

Phase 2 – preorder traversal:

- Compute x- and y-coordinates

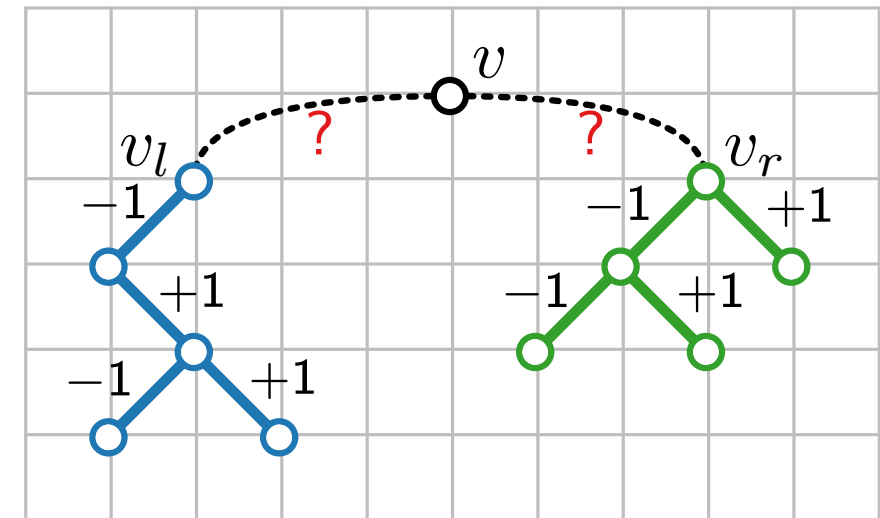

Layered Drawings – Algorithm Details

Phase 1 – postorder traversal:

- For each vertex v , compute horizontal displacement of left child v_l and right child v_r .
- At every vertex v store left and right **contour** of subtree $T(v)$.
- A contour is a linked list of vertex coordinates/offsets.

Phase 2 – preorder traversal:

- Compute x- and y-coordinates

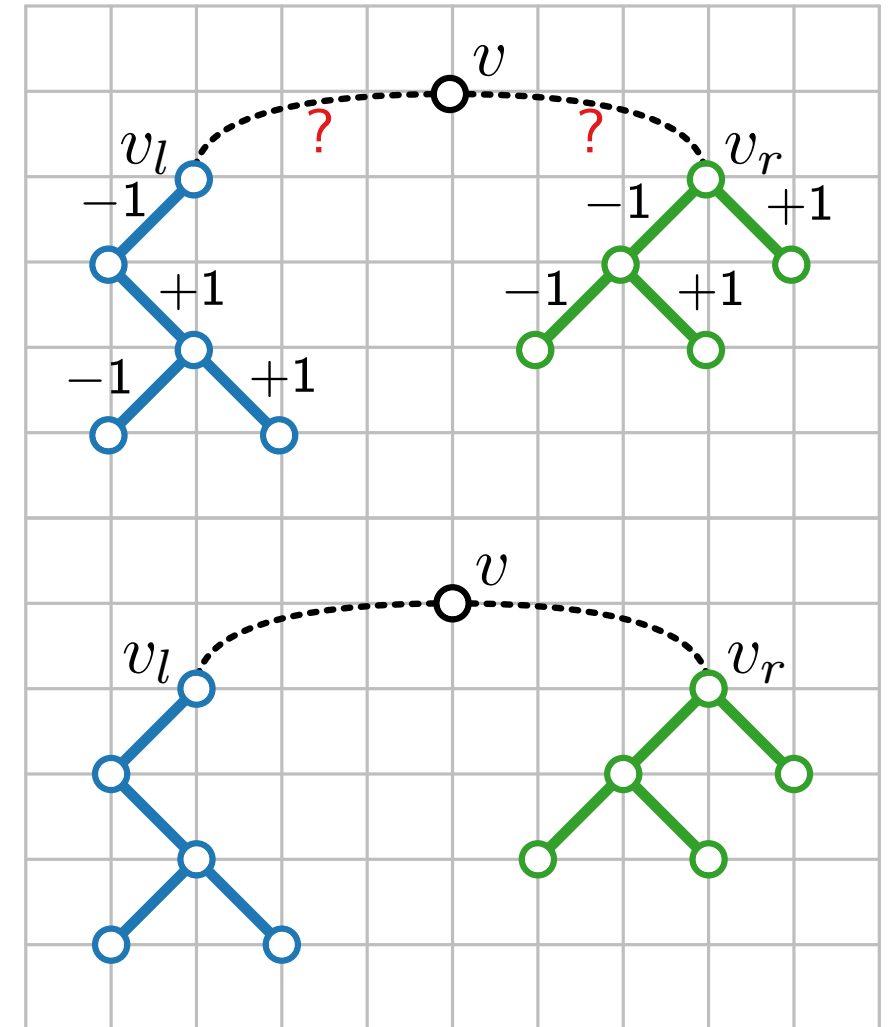

Layered Drawings – Algorithm Details

Phase 1 – postorder traversal:

- For each vertex v , compute horizontal displacement of left child v_l and right child v_r .
- At every vertex v store left and right **contour** of subtree $T(v)$.
- A contour is a linked list of vertex coordinates/offsets.

Phase 2 – preorder traversal:

- Compute x- and y-coordinates

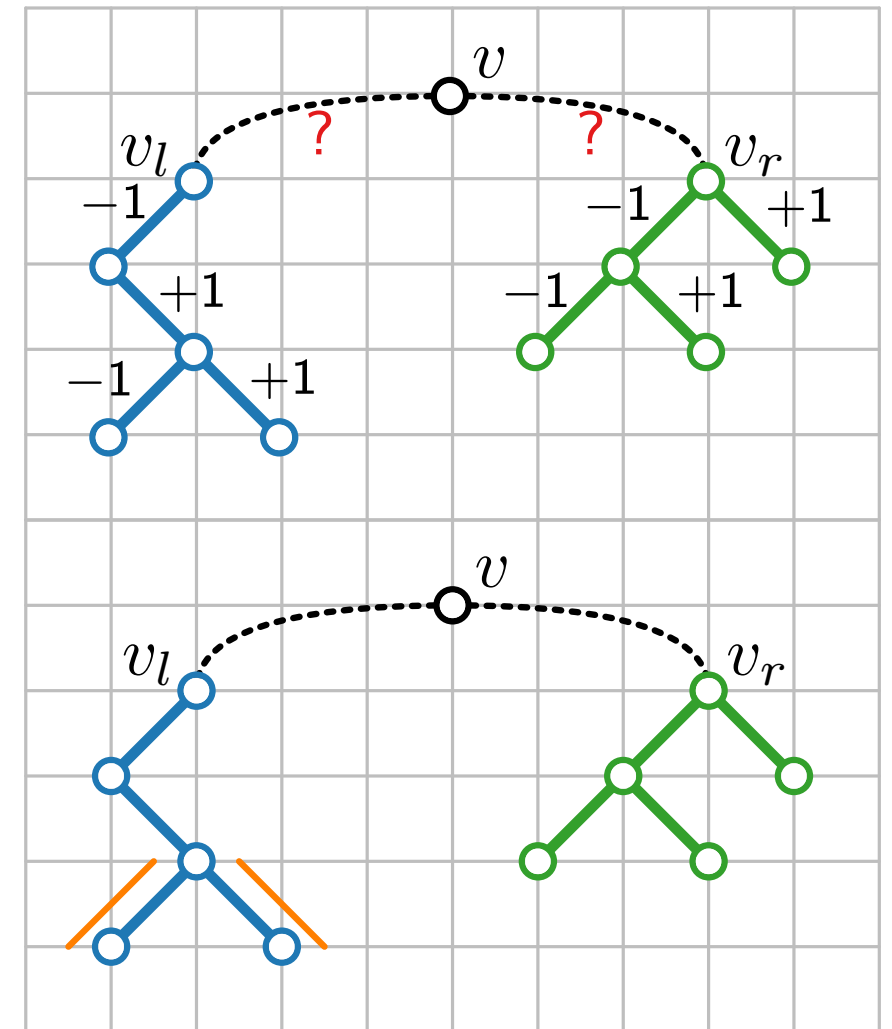

Layered Drawings – Algorithm Details

Phase 1 – postorder traversal:

- For each vertex v , compute horizontal displacement of left child v_l and right child v_r .
- At every vertex v store left and right **contour** of subtree $T(v)$.
- A contour is a linked list of vertex coordinates/offsets.

Phase 2 – preorder traversal:

- Compute x- and y-coordinates

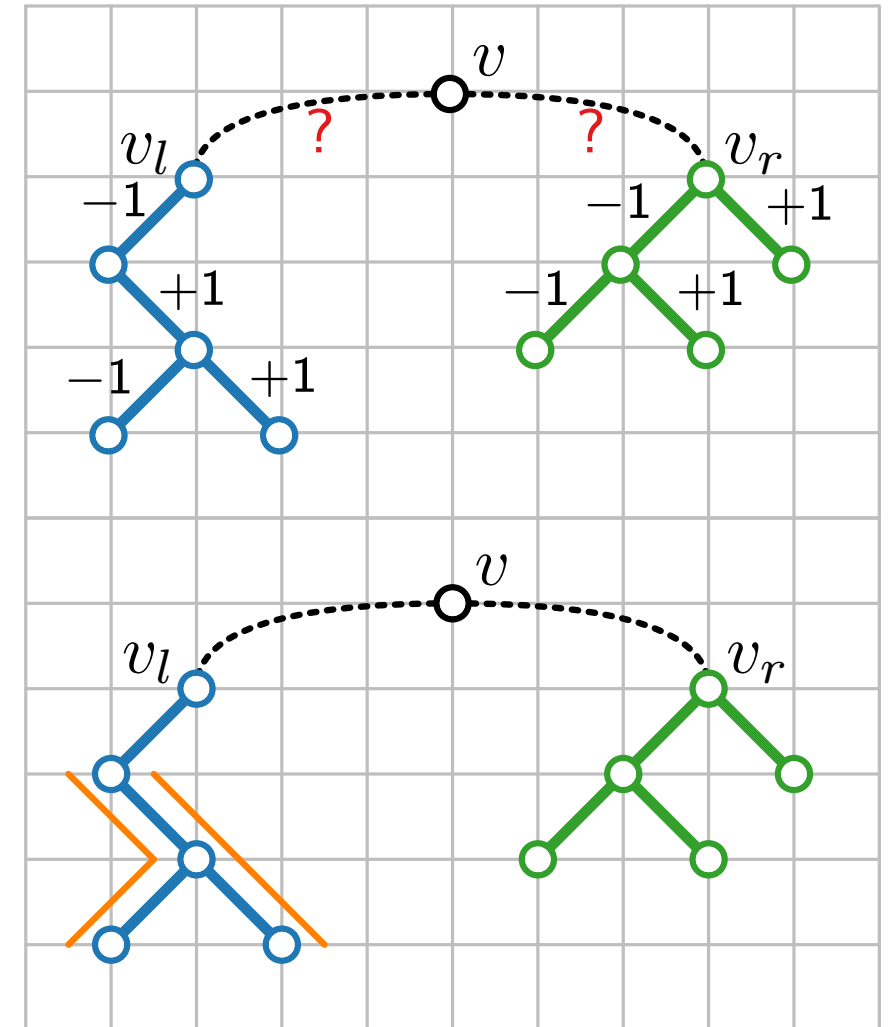

Layered Drawings – Algorithm Details

Phase 1 – postorder traversal:

- For each vertex v , compute horizontal displacement of left child v_l and right child v_r .
- At every vertex v store left and right **contour** of subtree $T(v)$.
- A contour is a linked list of vertex coordinates/offsets.

Phase 2 – preorder traversal:

- Compute x- and y-coordinates

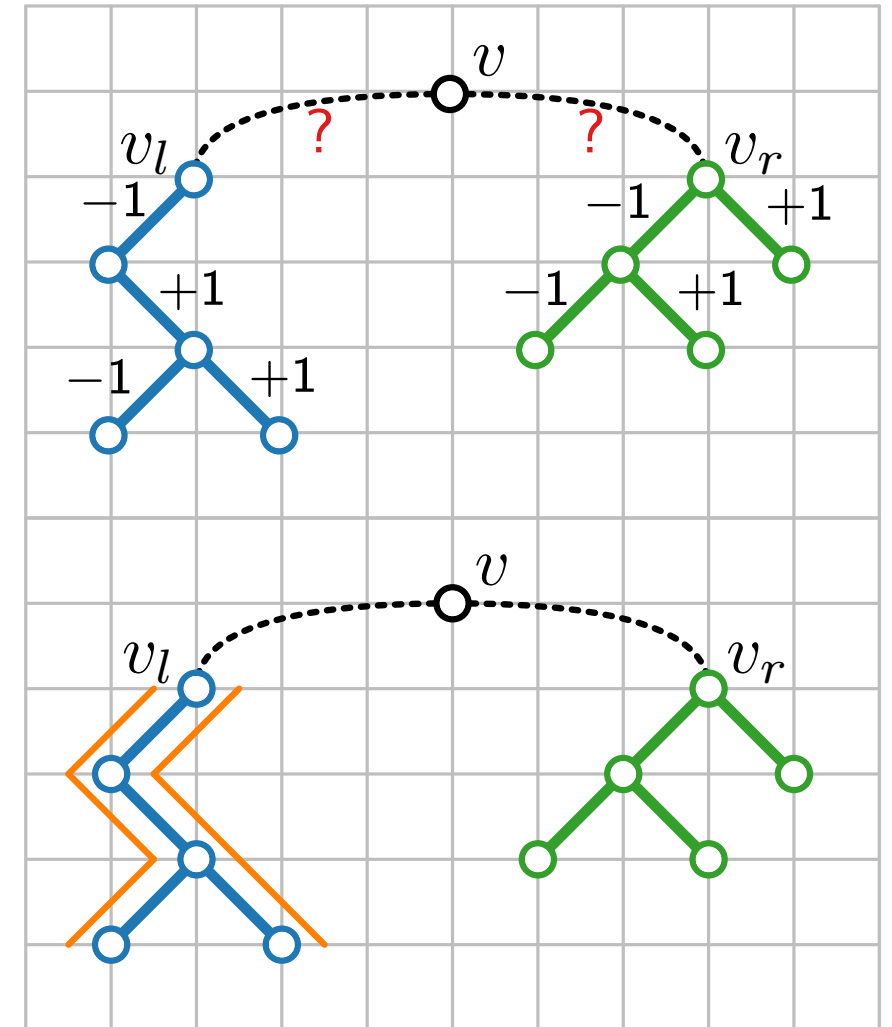

Layered Drawings – Algorithm Details

Phase 1 – postorder traversal:

- For each vertex v , compute horizontal displacement of left child v_l and right child v_r .
- At every vertex v store left and right **contour** of subtree $T(v)$.
- A contour is a linked list of vertex coordinates/offsets.

Phase 2 – preorder traversal:

- Compute x- and y-coordinates

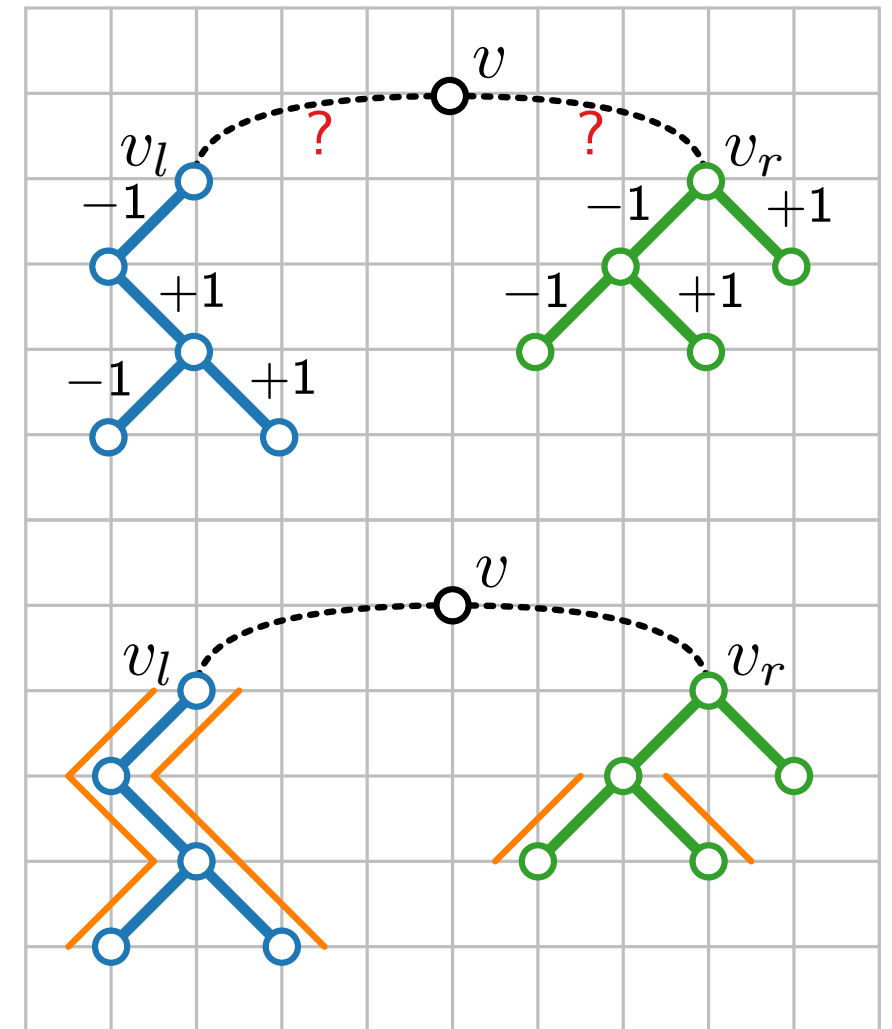

Layered Drawings – Algorithm Details

Phase 1 – postorder traversal:

- For each vertex v , compute horizontal displacement of left child v_l and right child v_r .
- At every vertex v store left and right **contour** of subtree $T(v)$.
- A contour is a linked list of vertex coordinates/offsets.

Phase 2 – preorder traversal:

- Compute x- and y-coordinates

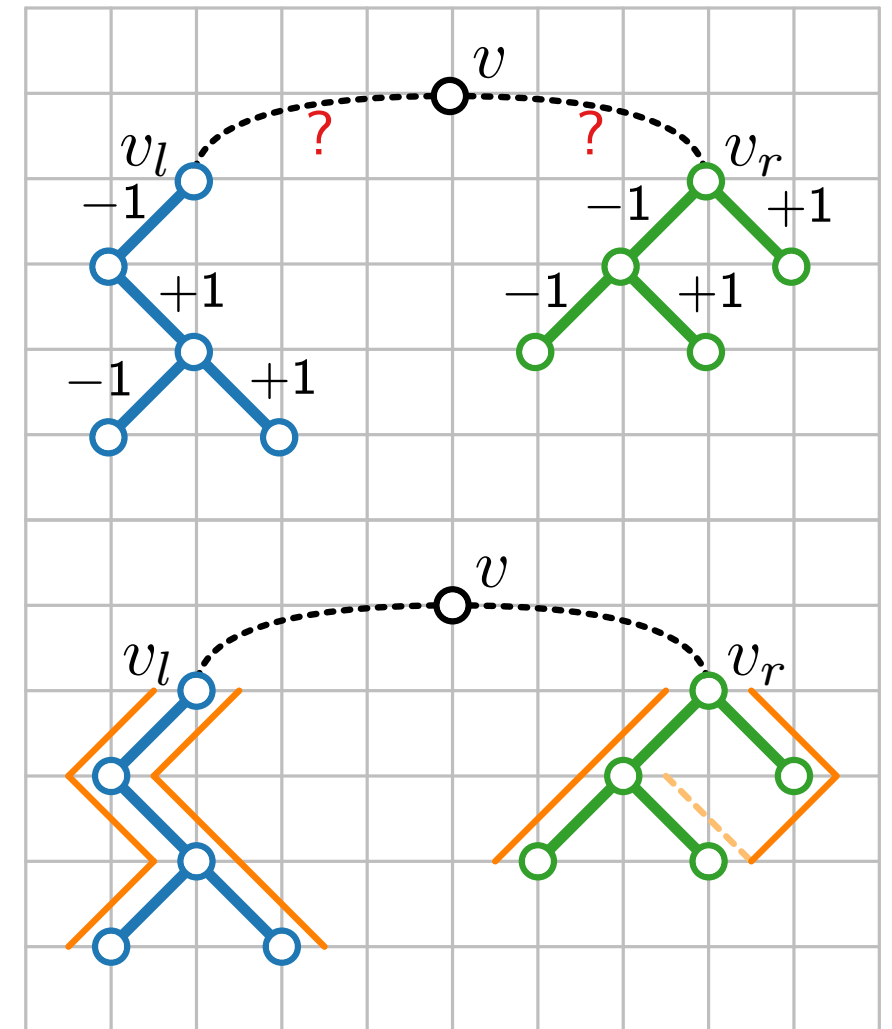

Layered Drawings – Algorithm Details

Phase 1 – postorder traversal:

- For each vertex v , compute horizontal displacement of left child v_l and right child v_r .
- At every vertex v store left and right **contour** of subtree $T(v)$.
- A contour is a linked list of vertex coordinates/offsets.
- Find $d_v = \min.$ horiz. distance between v_l and v_r .

Phase 2 – preorder traversal:

- Compute x- and y-coordinates

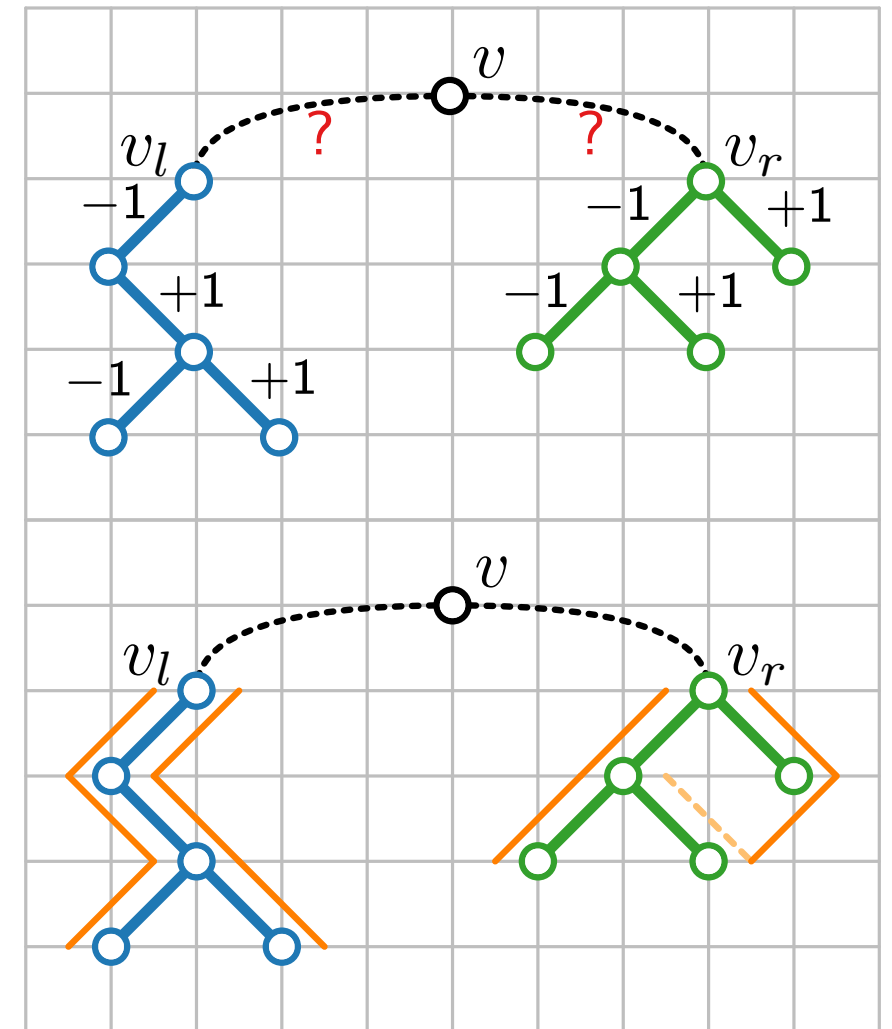

Layered Drawings – Algorithm Details

Phase 1 – postorder traversal:

- For each vertex v , compute horizontal displacement of left child v_l and right child v_r .
- At every vertex v store left and right **contour** of subtree $T(v)$.
- A contour is a linked list of vertex coordinates/offsets.
- Find $d_v = \min.$ horiz. distance between v_l and v_r .

Phase 2 – preorder traversal:

- Compute x- and y-coordinates

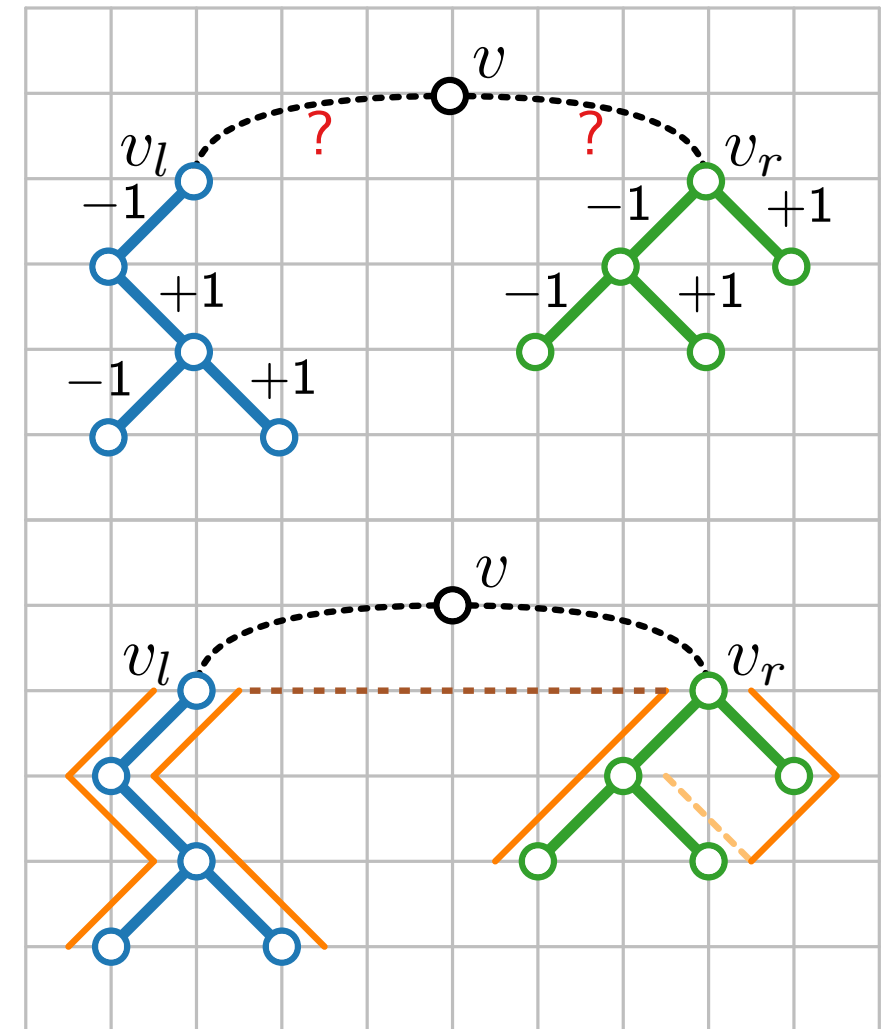

Layered Drawings – Algorithm Details

Phase 1 – postorder traversal:

- For each vertex v , compute horizontal displacement of left child v_l and right child v_r .
- At every vertex v store left and right **contour** of subtree $T(v)$.
- A contour is a linked list of vertex coordinates/offsets.
- Find $d_v = \min.$ horiz. distance between v_l and v_r .

Phase 2 – preorder traversal:

- Compute x- and y-coordinates

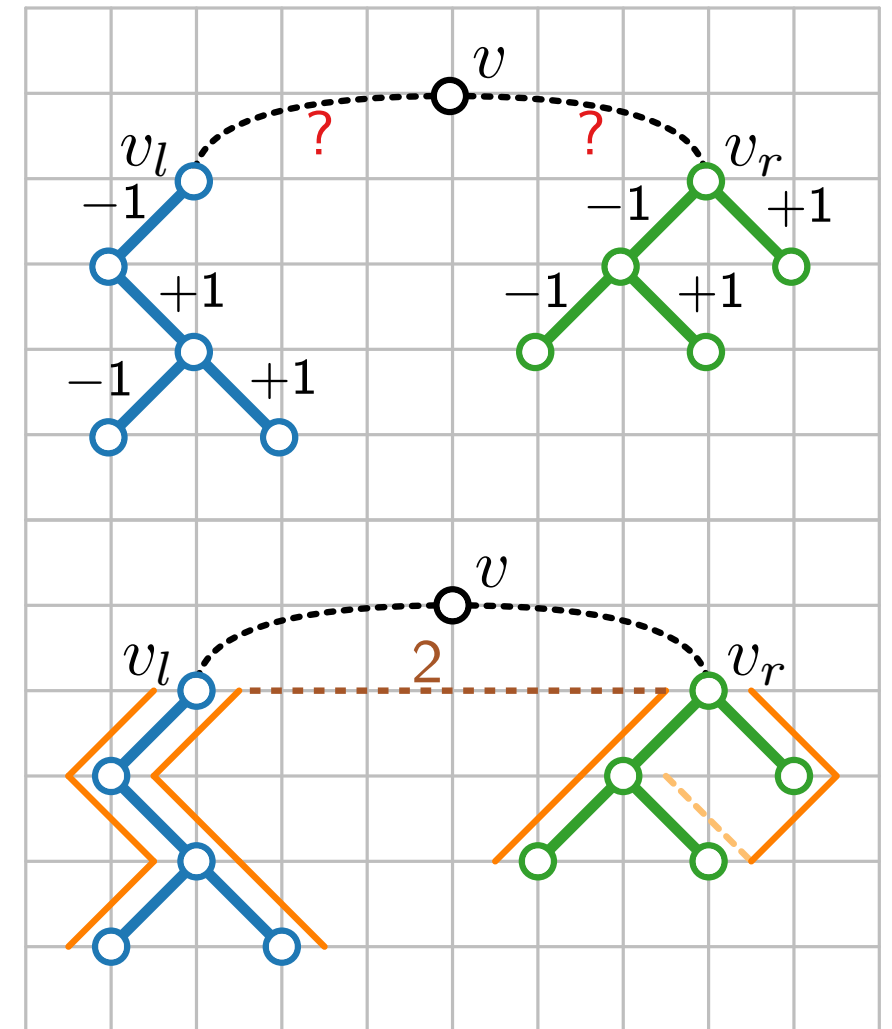

Layered Drawings – Algorithm Details

Phase 1 – postorder traversal:

- For each vertex v , compute horizontal displacement of left child v_l and right child v_r .
- At every vertex v store left and right **contour** of subtree $T(v)$.
- A contour is a linked list of vertex coordinates/offsets.
- Find $d_v = \min.$ horiz. distance between v_l and v_r .

Phase 2 – preorder traversal:

- Compute x- and y-coordinates

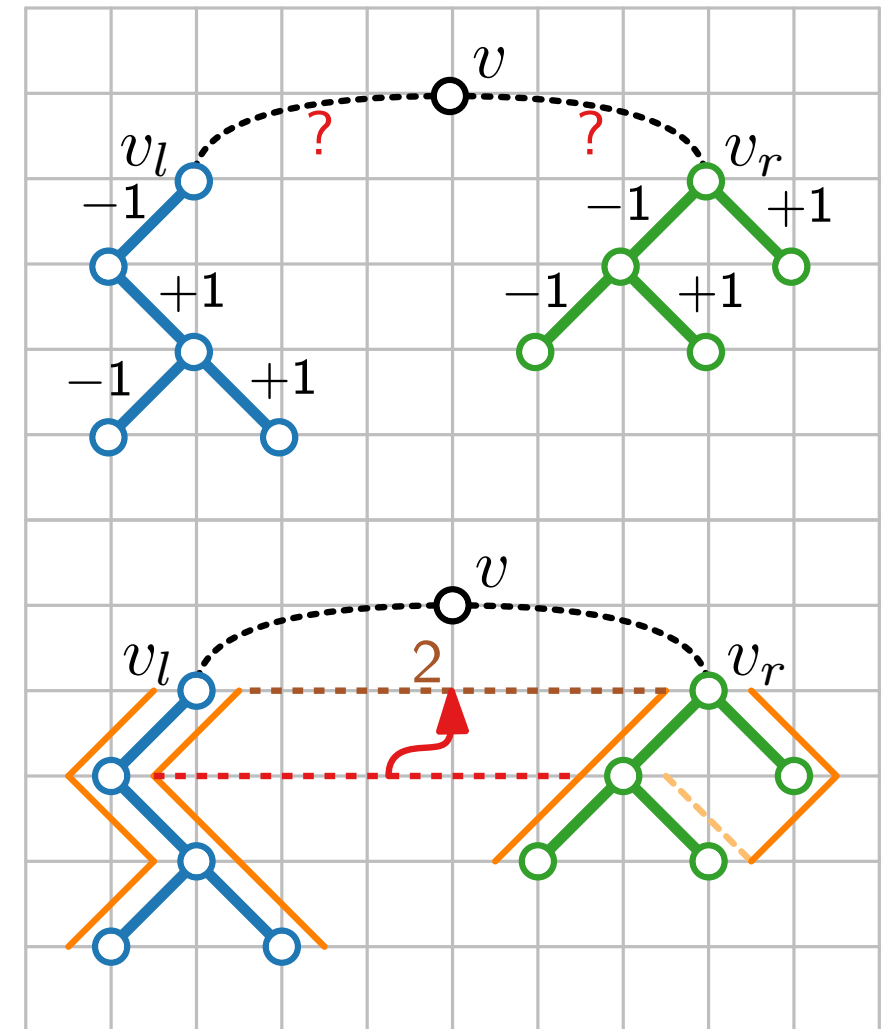

Layered Drawings – Algorithm Details

Phase 1 – postorder traversal:

- For each vertex v , compute horizontal displacement of left child v_l and right child v_r .
- At every vertex v store left and right **contour** of subtree $T(v)$.
- A contour is a linked list of vertex coordinates/offsets.
- Find $d_v = \min.$ horiz. distance between v_l and v_r .

Phase 2 – preorder traversal:

- Compute x- and y-coordinates

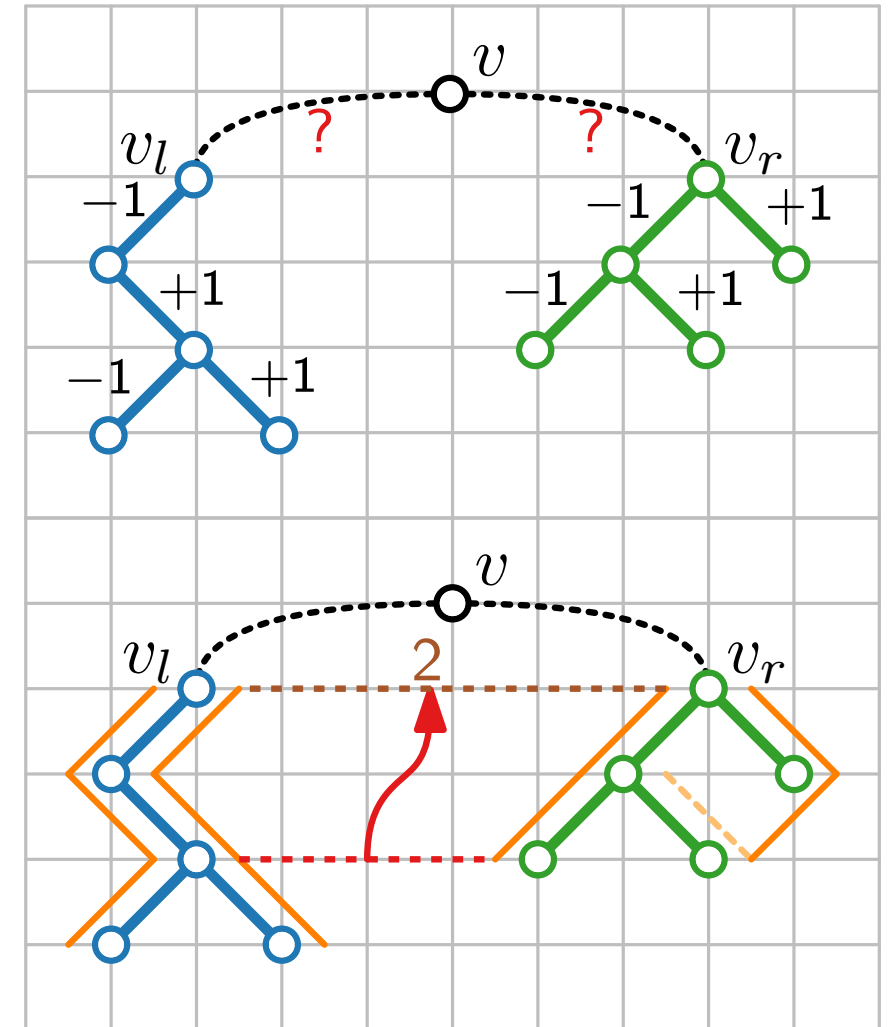

Layered Drawings – Algorithm Details

Phase 1 – postorder traversal:

- For each vertex v , compute horizontal displacement of left child v_l and right child v_r .
- At every vertex v store left and right **contour** of subtree $T(v)$.
- A contour is a linked list of vertex coordinates/offsets.
- Find $d_v = \min.$ horiz. distance between v_l and v_r .

Phase 2 – preorder traversal:

- Compute x- and y-coordinates

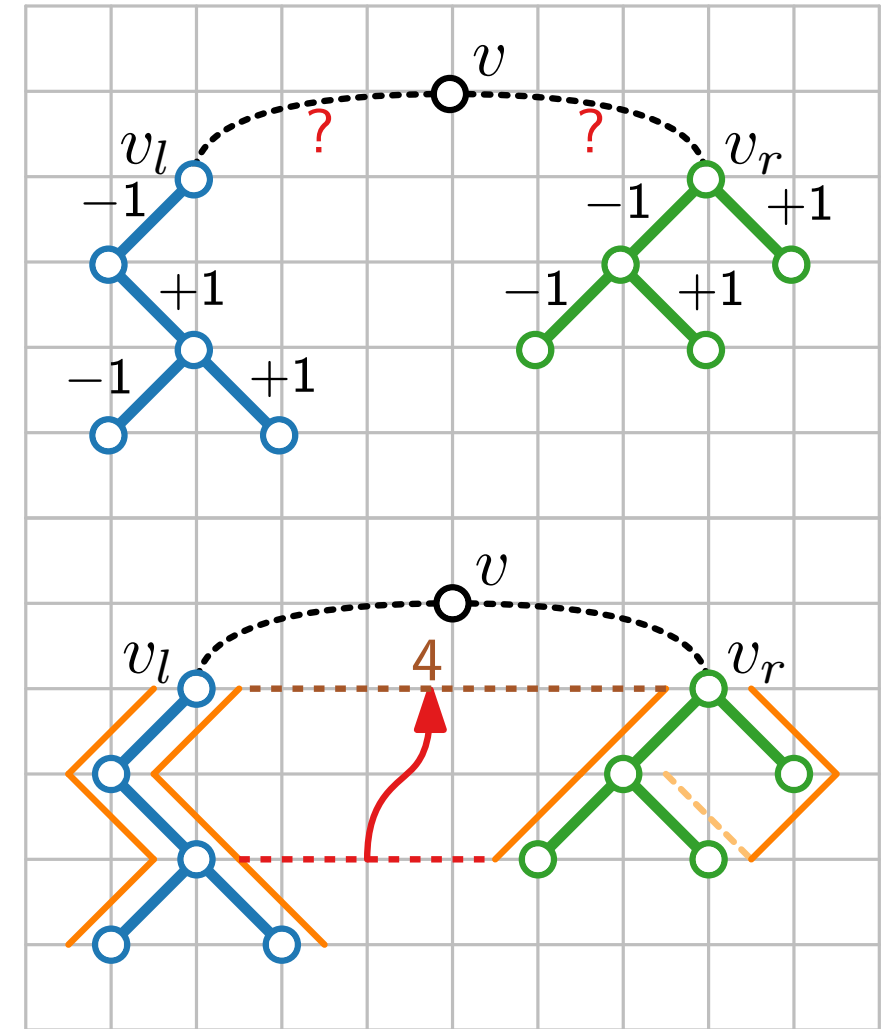

Layered Drawings – Algorithm Details

Phase 1 – postorder traversal:

- For each vertex v , compute horizontal displacement of left child v_l and right child v_r .
- $x\text{-offset}(v_l) = -\lceil d_v/2 \rceil$, $x\text{-offset}(v_r) = \lceil d_v/2 \rceil$
- At every vertex v store left and right **contour** of subtree $T(v)$.
- A contour is a linked list of vertex coordinates/offsets.
- Find $d_v = \text{min. horiz. distance between } v_l \text{ and } v_r$.

Phase 2 – preorder traversal:

- Compute x- and y-coordinates

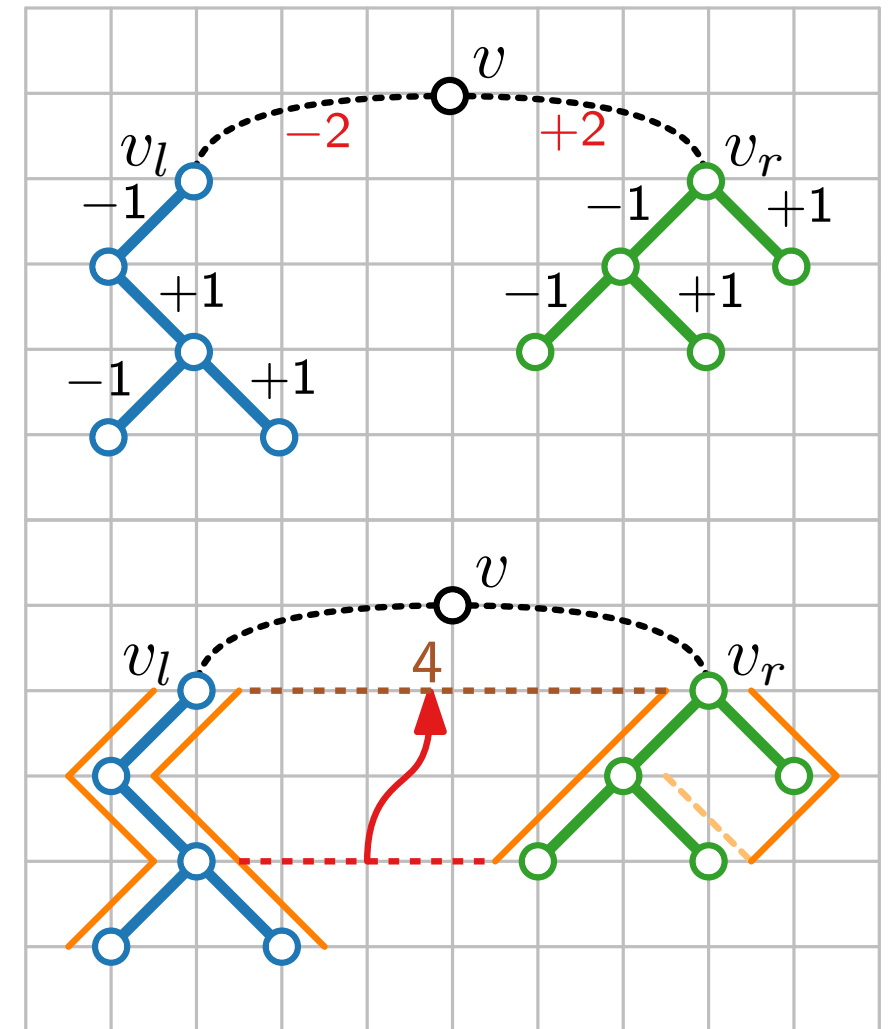

Layered Drawings – Algorithm Details

Phase 1 – postorder traversal:

- For each vertex v , compute horizontal displacement of left child v_l and right child v_r .
- $x\text{-offset}(v_l) = -\lceil d_v/2 \rceil$, $x\text{-offset}(v_r) = \lceil d_v/2 \rceil$
- At every vertex v store left and right **contour** of subtree $T(v)$.
- A contour is a linked list of vertex coordinates/offsets.
- Find $d_v = \text{min. horiz. distance between } v_l \text{ and } v_r$.

Phase 2 – preorder traversal:

- Compute x- and y-coordinates

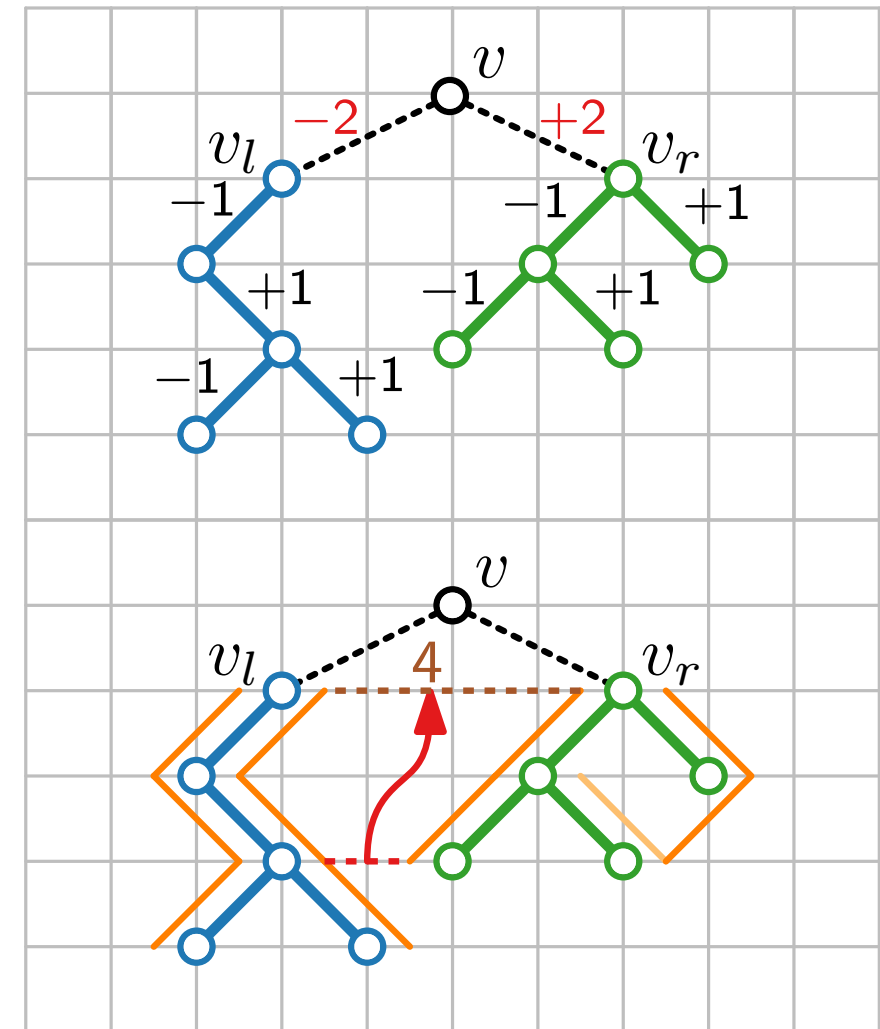

Layered Drawings – Algorithm Details

Phase 1 – postorder traversal:

- For each vertex v , compute horizontal displacement of left child v_l and right child v_r .
- $x\text{-offset}(v_l) = -\lceil d_v/2 \rceil$, $x\text{-offset}(v_r) = \lceil d_v/2 \rceil$
- At every vertex v store left and right **contour** of subtree $T(v)$.
- A contour is a linked list of vertex coordinates/offsets.
- Find $d_v = \text{min. horiz. distance between } v_l \text{ and } v_r$.

Phase 2 – preorder traversal:

- Compute x- and y-coordinates

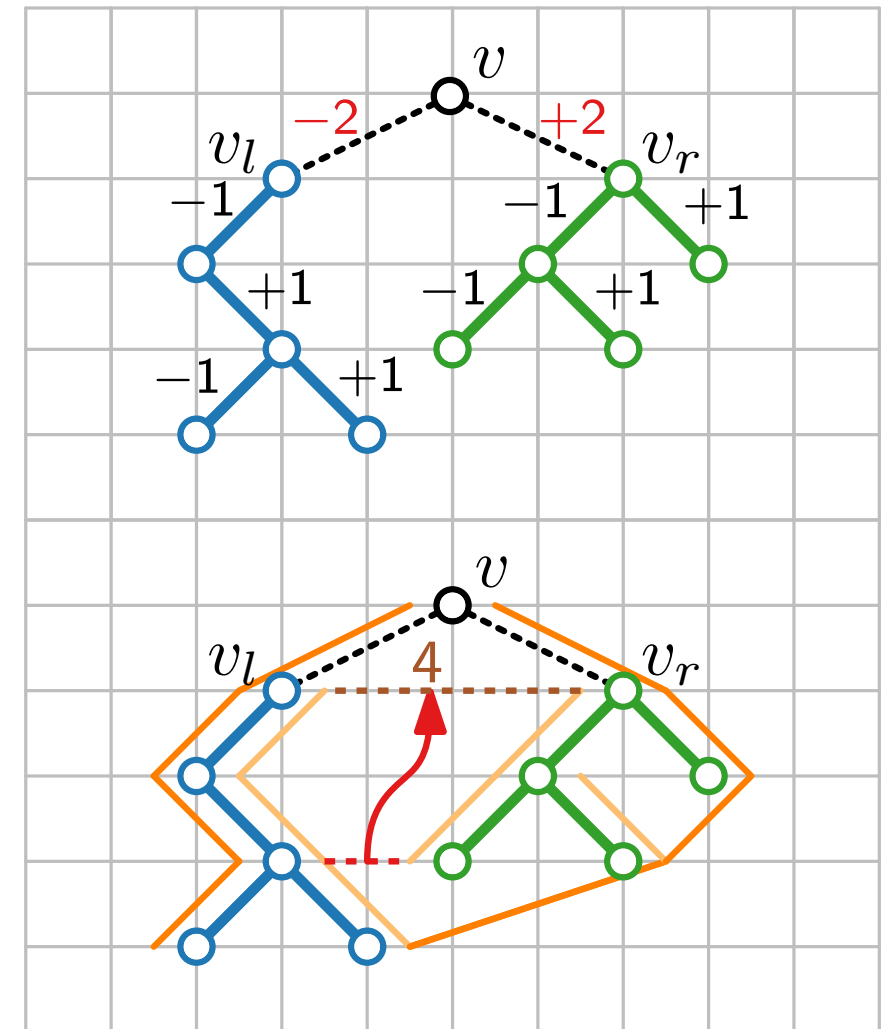

Layered Drawings – Algorithm Details

Phase 1 – postorder traversal:

- For each vertex v , compute horizontal displacement of left child v_l and right child v_r .
- $x\text{-offset}(v_l) = -\lceil d_v/2 \rceil$, $x\text{-offset}(v_r) = \lceil d_v/2 \rceil$
- At every vertex v store left and right **contour** of subtree $T(v)$.
- A contour is a linked list of vertex coordinates/offsets.
- Find $d_v = \text{min. horiz. distance between } v_l \text{ and } v_r$.

Phase 2 – preorder traversal:

- Compute x- and y-coordinates

Runtime?

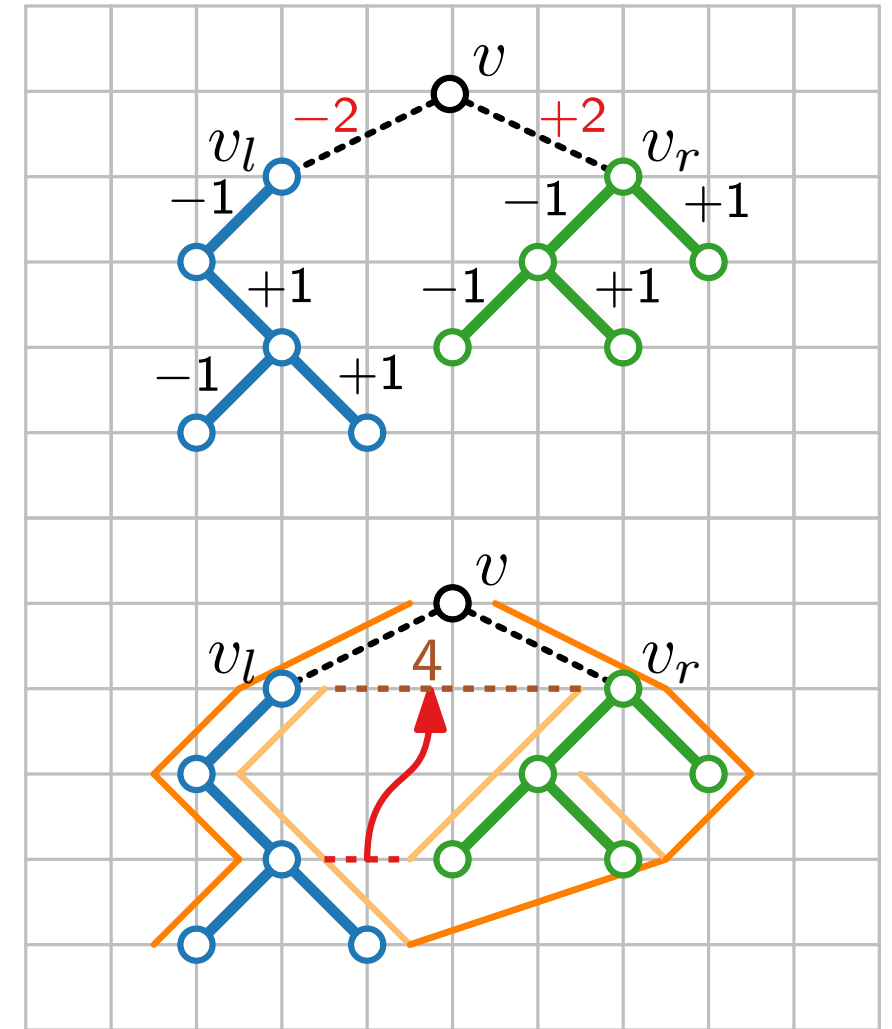

Layered Drawings – Algorithm Details

Phase 1 – postorder traversal:

- For each vertex v , compute horizontal displacement of left child v_l and right child v_r .
- $x\text{-offset}(v_l) = -\lceil d_v/2 \rceil$, $x\text{-offset}(v_r) = \lceil d_v/2 \rceil$
- At every vertex v store left and right **contour** of subtree $T(v)$.
- A contour is a linked list of vertex coordinates/offsets.
- Find $d_v = \text{min. horiz. distance between } v_l \text{ and } v_r$.

Phase 2 – preorder traversal:

- Compute x- and y-coordinates

Runtime?

- How often do we take a **step along a contour**?

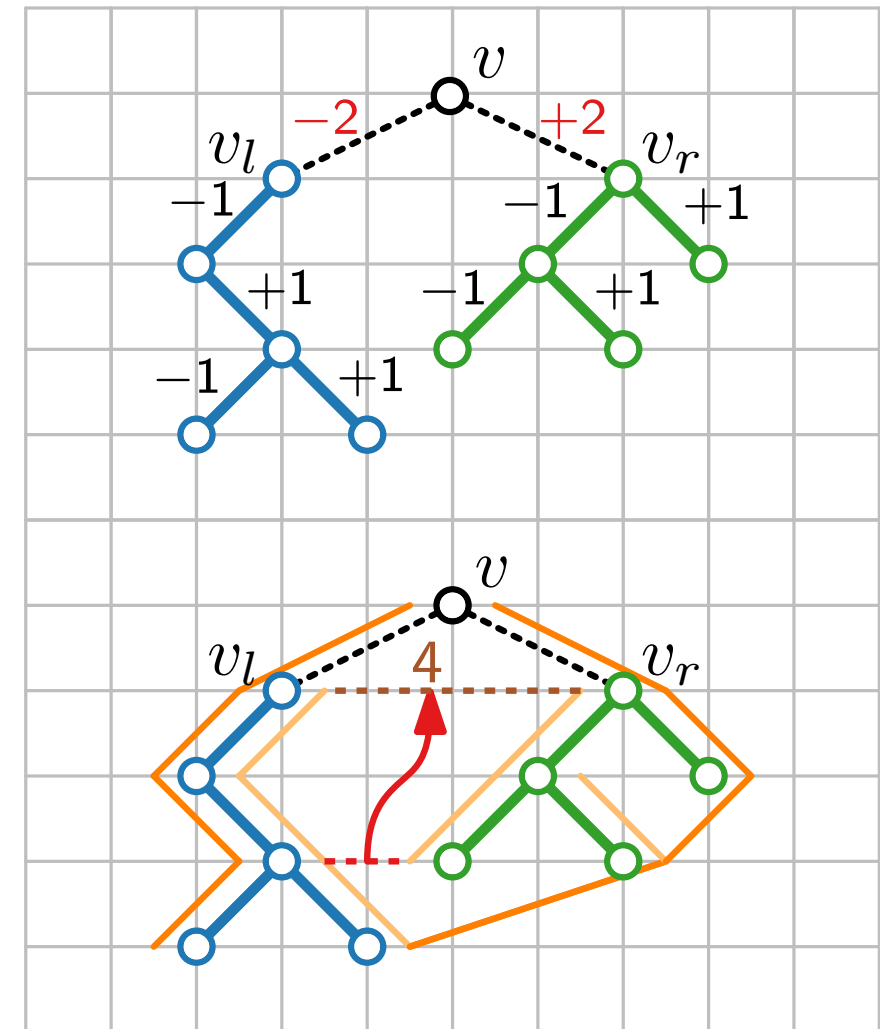

Layered Drawings – Algorithm Details

Phase 1 – postorder traversal:

- For each vertex v , compute horizontal displacement of left child v_l and right child v_r .
- $x\text{-offset}(v_l) = -\lceil d_v/2 \rceil$, $x\text{-offset}(v_r) = \lceil d_v/2 \rceil$
- At every vertex v store left and right **contour** of subtree $T(v)$.
- A contour is a linked list of vertex coordinates/offsets.
- Find $d_v = \text{min. horiz. distance between } v_l \text{ and } v_r$.

Phase 2 – preorder traversal:

- Compute x- and y-coordinates

Runtime?

- How often do we take a **step along a contour**?

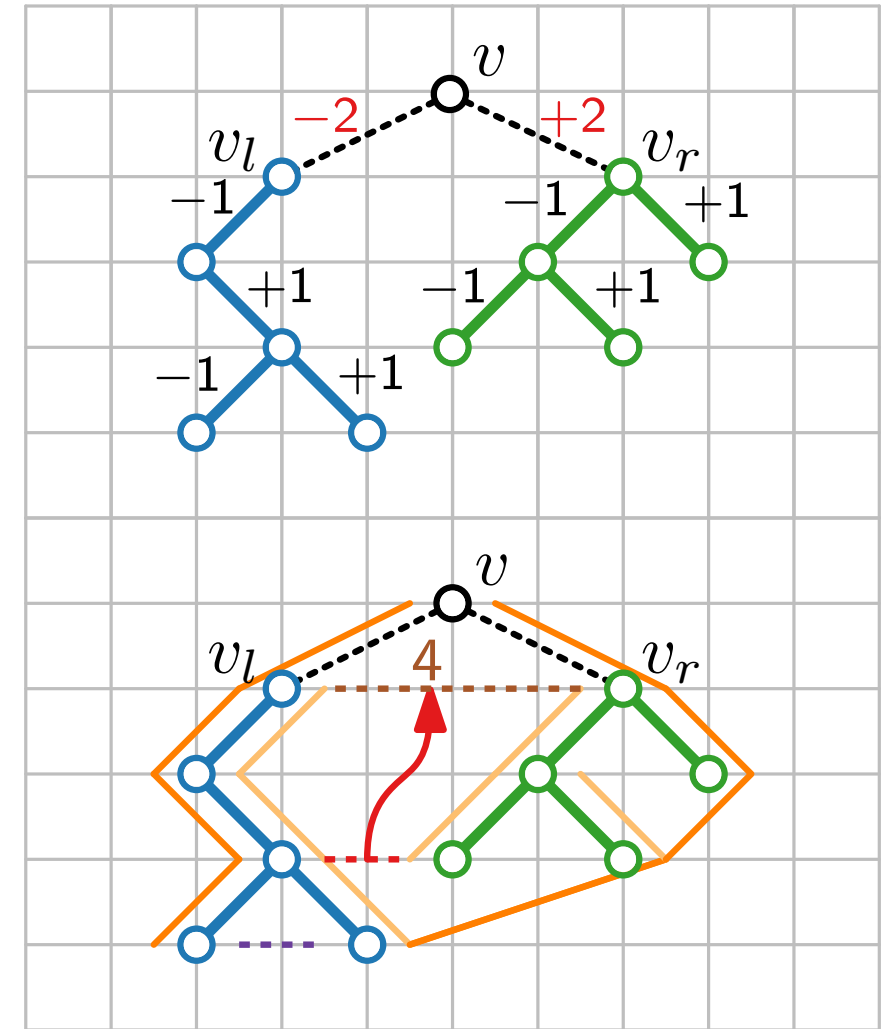

Layered Drawings – Algorithm Details

Phase 1 – postorder traversal:

- For each vertex v , compute horizontal displacement of left child v_l and right child v_r .
- $x\text{-offset}(v_l) = -\lceil d_v/2 \rceil$, $x\text{-offset}(v_r) = \lceil d_v/2 \rceil$
- At every vertex v store left and right **contour** of subtree $T(v)$.
- A contour is a linked list of vertex coordinates/offsets.
- Find $d_v = \text{min. horiz. distance between } v_l \text{ and } v_r$.

Phase 2 – preorder traversal:

- Compute x- and y-coordinates

Runtime?

- How often do we take a **step along a contour**?

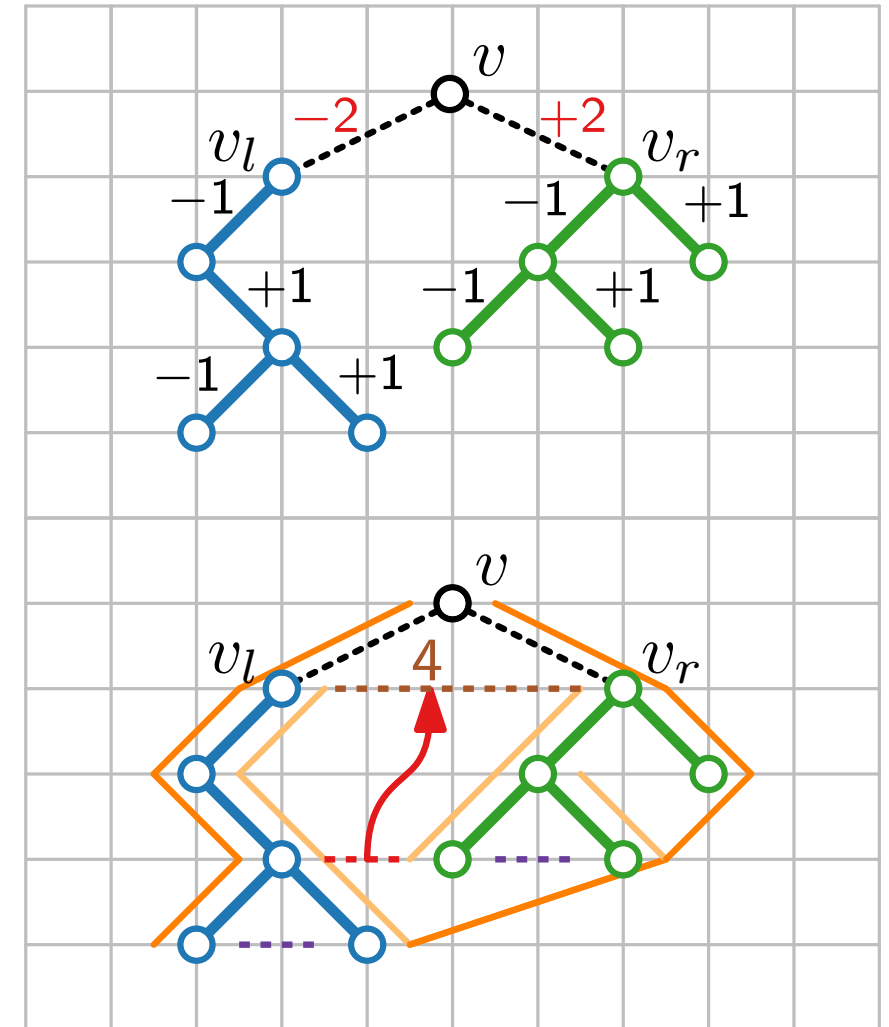

Layered Drawings – Algorithm Details

Phase 1 – postorder traversal:

- For each vertex v , compute horizontal displacement of left child v_l and right child v_r .
- $x\text{-offset}(v_l) = -\lceil d_v/2 \rceil$, $x\text{-offset}(v_r) = \lceil d_v/2 \rceil$
- At every vertex v store left and right **contour** of subtree $T(v)$.
- A contour is a linked list of vertex coordinates/offsets.
- Find $d_v = \text{min. horiz. distance between } v_l \text{ and } v_r$.

Phase 2 – preorder traversal:

- Compute x- and y-coordinates

Runtime?

- How often do we take a **step along a contour**?

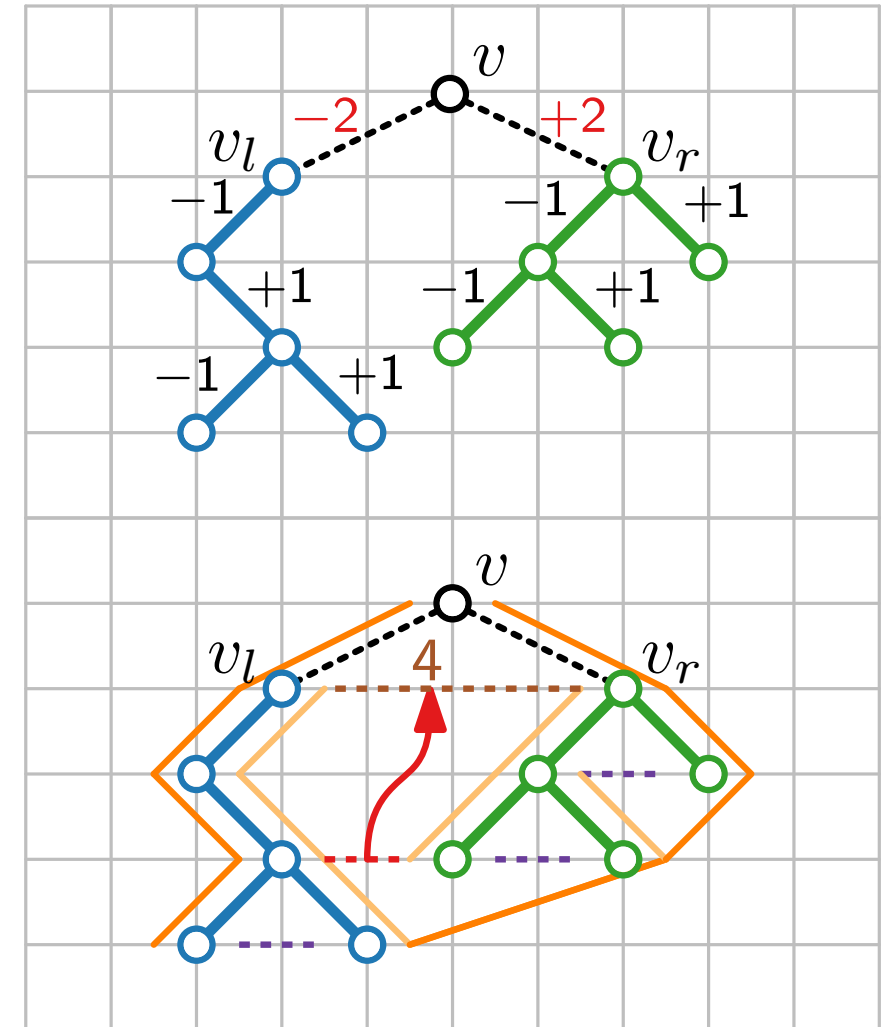

Layered Drawings – Algorithm Details

Phase 1 – postorder traversal:

- For each vertex v , compute horizontal displacement of left child v_l and right child v_r .
- $x\text{-offset}(v_l) = -\lceil d_v/2 \rceil$, $x\text{-offset}(v_r) = \lceil d_v/2 \rceil$
- At every vertex v store left and right **contour** of subtree $T(v)$.
- A contour is a linked list of vertex coordinates/offsets.
- Find $d_v = \text{min. horiz. distance between } v_l \text{ and } v_r$.

Phase 2 – preorder traversal:

- Compute x- and y-coordinates

Runtime?

- How often do we take a **step along a contour**?

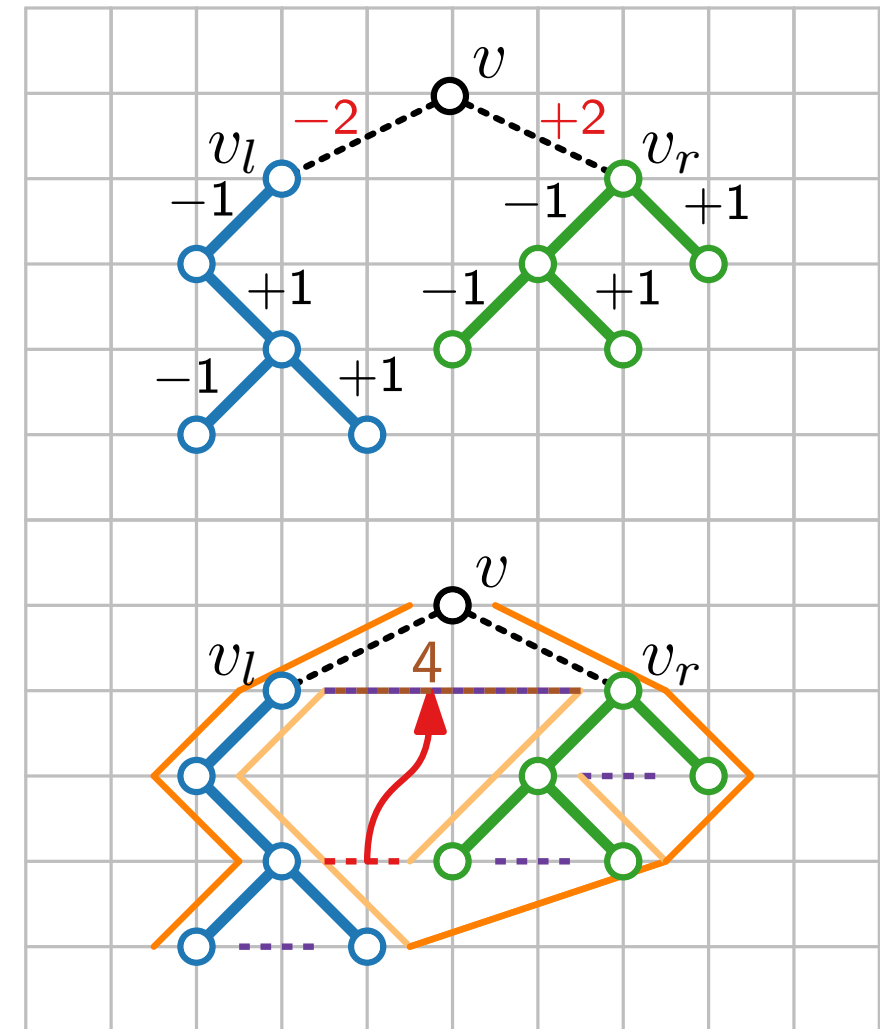

Layered Drawings – Algorithm Details

Phase 1 – postorder traversal:

- For each vertex v , compute horizontal displacement of left child v_l and right child v_r .
- $x\text{-offset}(v_l) = -\lceil d_v/2 \rceil$, $x\text{-offset}(v_r) = \lceil d_v/2 \rceil$
- At every vertex v store left and right **contour** of subtree $T(v)$.
- A contour is a linked list of vertex coordinates/offsets.
- Find $d_v = \text{min. horiz. distance between } v_l \text{ and } v_r$.

Phase 2 – preorder traversal:

- Compute x- and y-coordinates

Runtime?

- How often do we take a **step along a contour**?

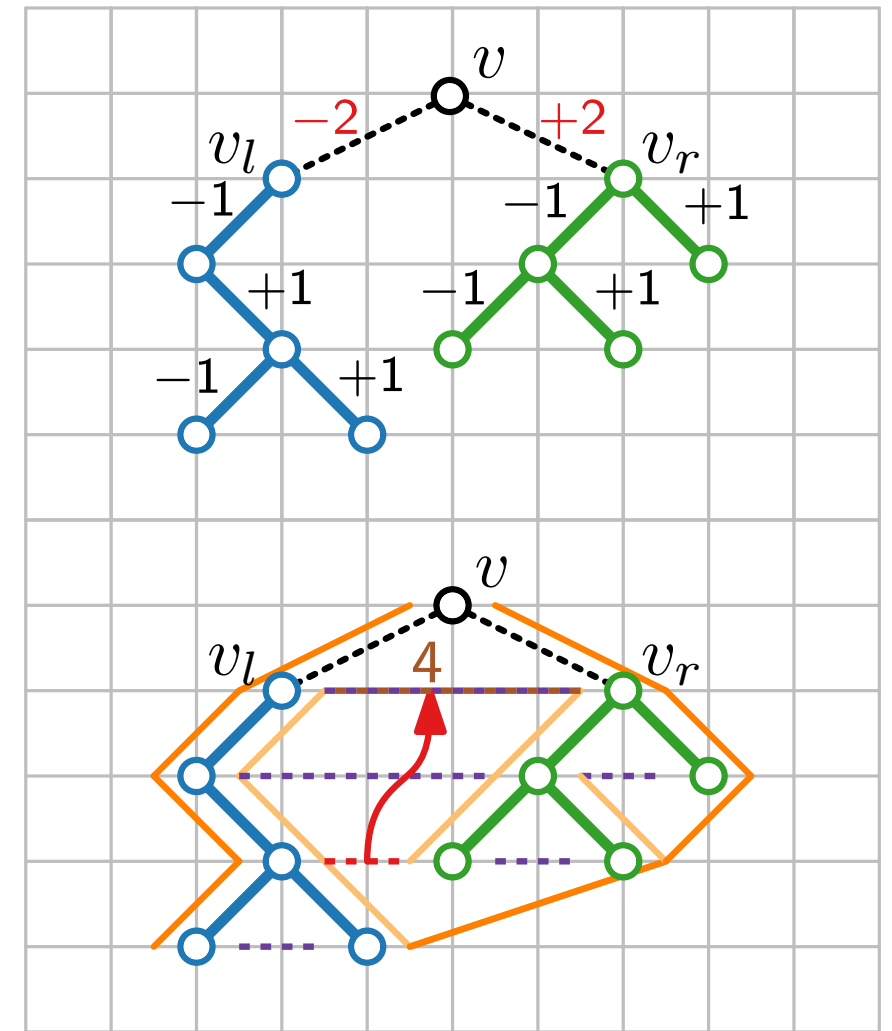

Layered Drawings – Algorithm Details

Phase 1 – postorder traversal:

- For each vertex v , compute horizontal displacement of left child v_l and right child v_r .
- $x\text{-offset}(v_l) = -\lceil d_v/2 \rceil$, $x\text{-offset}(v_r) = \lceil d_v/2 \rceil$
- At every vertex v store left and right **contour** of subtree $T(v)$.
- A contour is a linked list of vertex coordinates/offsets.
- Find $d_v = \text{min. horiz. distance between } v_l \text{ and } v_r$.

Phase 2 – preorder traversal:

- Compute x- and y-coordinates

Runtime?

- How often do we take a **step along a contour**?

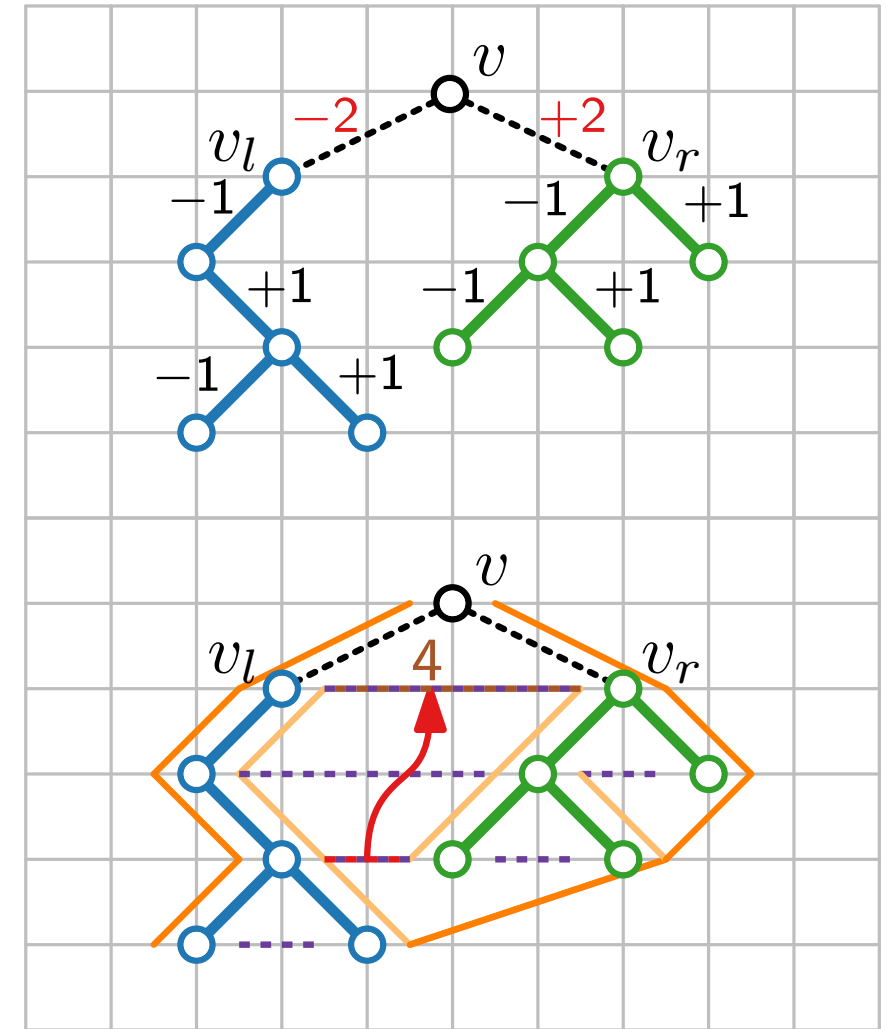

Layered Drawings – Result

Theorem.

[Reingold & Tilford '81]

Let T be a binary tree with n vertices. We can construct a drawing Γ of T in $\mathcal{O}(n)$ time such that:

Layered Drawings – Result

Theorem.

[Reingold & Tilford '81]

Let T be a binary tree with n vertices. We can construct a drawing Γ of T in $\mathcal{O}(n)$ time such that:

- Γ is planar, straight-line and strictly downward

Layered Drawings – Result

Theorem.

[Reingold & Tilford '81]

Let T be a binary tree with n vertices. We can construct a drawing Γ of T in $\mathcal{O}(n)$ time such that:

- Γ is planar, straight-line and strictly downward
- Γ is layered: y-coordinate of vertex v is $-\text{depth}(v)$

Layered Drawings – Result

Theorem.

[Reingold & Tilford '81]

Let T be a binary tree with n vertices. We can construct a drawing Γ of T in $\mathcal{O}(n)$ time such that:

- Γ is planar, straight-line and strictly downward
- Γ is layered: y-coordinate of vertex v is $-\text{depth}(v)$
- Horizontal and vertical distances are at least 1

Layered Drawings – Result

Theorem.

[Reingold & Tilford '81]

Let T be a binary tree with n vertices. We can construct a drawing Γ of T in $\mathcal{O}(n)$ time such that:

- Γ is planar, straight-line and strictly downward
- Γ is layered: y-coordinate of vertex v is $-\text{depth}(v)$
- Horizontal and vertical distances are at least 1
- Each vertex with > 1 child is centered w.r.t. its children

Layered Drawings – Result

Theorem.

[Reingold & Tilford '81]

Let T be a binary tree with n vertices. We can construct a drawing Γ of T in $\mathcal{O}(n)$ time such that:

- Γ is planar, straight-line and strictly downward
- Γ is layered: y-coordinate of vertex v is $-\text{depth}(v)$
- Horizontal and vertical distances are at least 1
- Each vertex with > 1 child is centered w.r.t. its children
- Area of Γ is in $\mathcal{O}(n^2)$

Layered Drawings – Result

Theorem.

[Reingold & Tilford '81]

Let T be a binary tree with n vertices. We can construct a drawing Γ of T in $\mathcal{O}(n)$ time such that:

- Γ is planar, straight-line and strictly downward
- Γ is layered: y-coordinate of vertex v is $-\text{depth}(v)$
- Horizontal and vertical distances are at least 1
- Each vertex with > 1 child is centered w.r.t. its children
- Area of Γ is in $\mathcal{O}(n^2)$ – but not optimal!

Layered Drawings – Result

Theorem.

[Reingold & Tilford '81]

Let T be a binary tree with n vertices. We can construct a drawing Γ of T in $\mathcal{O}(n)$ time such that:

- Γ is planar, straight-line and strictly downward
- Γ is layered: y-coordinate of vertex v is $-\text{depth}(v)$
- Horizontal and vertical distances are at least 1
- Each vertex with > 1 child is centered w.r.t. its children
- Area of Γ is in $\mathcal{O}(n^2)$ – but not optimal!

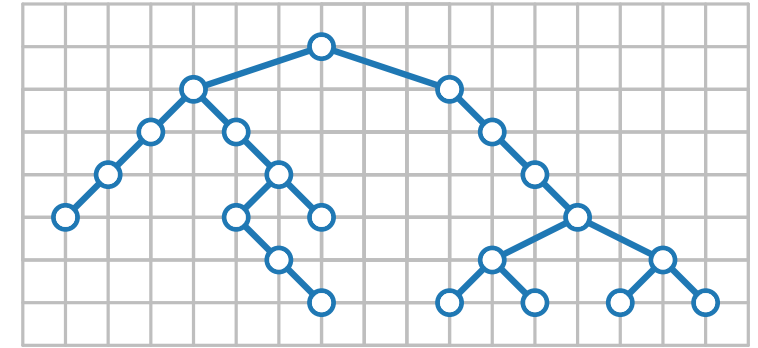

Layered Drawings – Result

Theorem.

[Reingold & Tilford '81]

Let T be a binary tree with n vertices. We can construct a drawing Γ of T in $\mathcal{O}(n)$ time such that:

- Γ is planar, straight-line and strictly downward
- Γ is layered: y-coordinate of vertex v is $-\text{depth}(v)$
- Horizontal and vertical distances are at least 1
- Each vertex with > 1 child is centered w.r.t. its children
- Area of Γ is in $\mathcal{O}(n^2)$ – but not optimal!

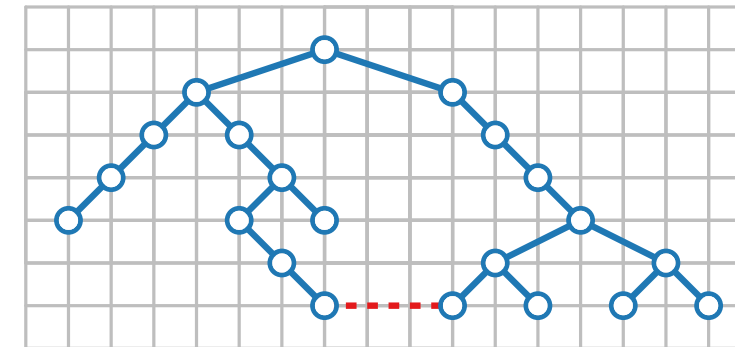

Layered Drawings – Result

Theorem.

[Reingold & Tilford '81]

Let T be a binary tree with n vertices. We can construct a drawing Γ of T in $\mathcal{O}(n)$ time such that:

- Γ is planar, straight-line and strictly downward
- Γ is layered: y-coordinate of vertex v is $-\text{depth}(v)$
- Horizontal and vertical distances are at least 1
- Each vertex with > 1 child is centered w.r.t. its children
- Area of Γ is in $\mathcal{O}(n^2)$ – but not optimal!

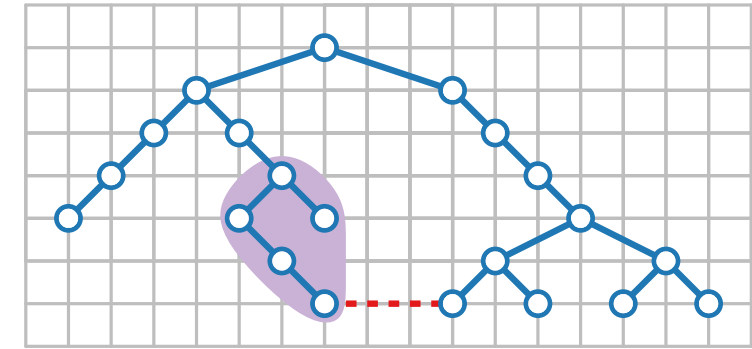

Layered Drawings – Result

Theorem.

[Reingold & Tilford '81]

Let T be a binary tree with n vertices. We can construct a drawing Γ of T in $\mathcal{O}(n)$ time such that:

- Γ is planar, straight-line and strictly downward
- Γ is layered: y-coordinate of vertex v is $-\text{depth}(v)$
- Horizontal and vertical distances are at least 1
- Each vertex with > 1 child is centered w.r.t. its children
- Area of Γ is in $\mathcal{O}(n^2)$ – but not optimal!

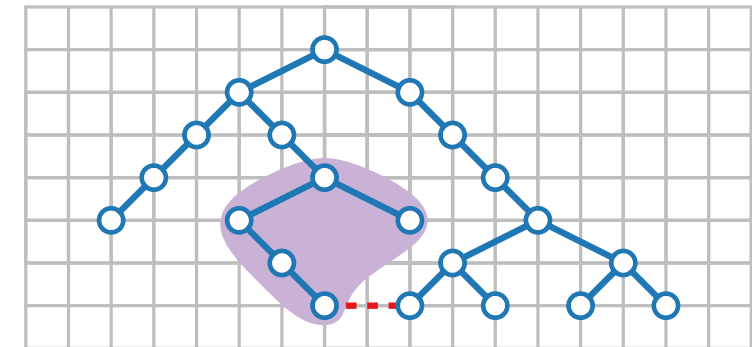
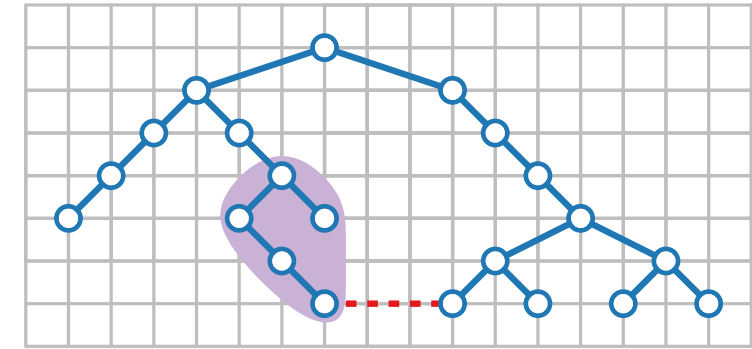

Layered Drawings – Result

Theorem.

[Reingold & Tilford '81]

Let T be a binary tree with n vertices. We can construct a drawing Γ of T in $\mathcal{O}(n)$ time such that:

- Γ is planar, straight-line and strictly downward
- Γ is layered: y-coordinate of vertex v is $-\text{depth}(v)$
- Horizontal and vertical distances are at least 1
- Each vertex with > 1 child is centered w.r.t. its children
- Area of Γ is in $\mathcal{O}(n^2)$ – but not optimal! ← NP-hard

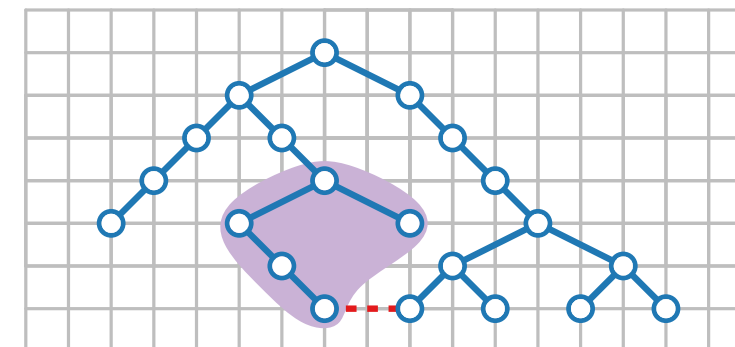
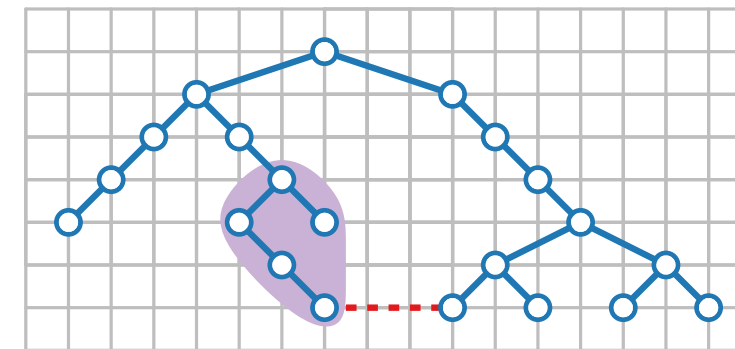

Layered Drawings – Result

Theorem.

[Reingold & Tilford '81]

Let T be a binary tree with n vertices. We can construct a drawing Γ of T in $\mathcal{O}(n)$ time such that:

- Γ is planar, straight-line and strictly downward
- Γ is layered: y-coordinate of vertex v is $-\text{depth}(v)$
- Horizontal and vertical distances are at least 1
- Each vertex with > 1 child is centered w.r.t. its children
- Area of Γ is in $\mathcal{O}(n^2)$ – but not optimal! ← NP-hard
- Simply isomorphic subtrees have congruent drawings, up to translation

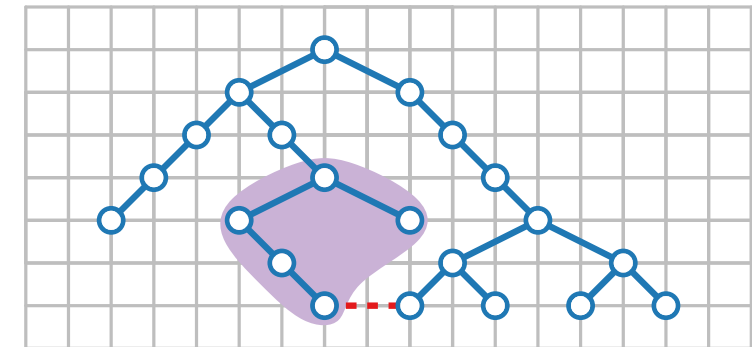
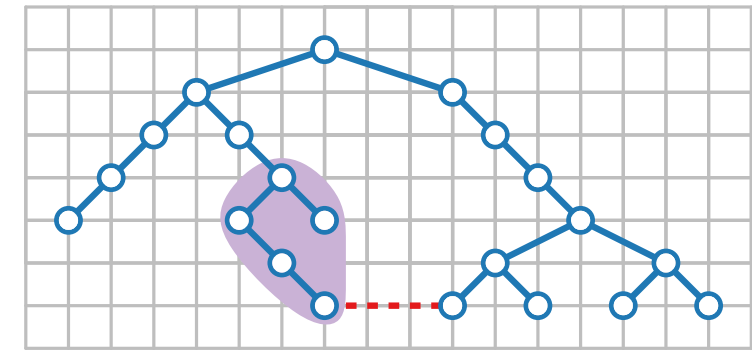

Layered Drawings – Result

Theorem.

[Reingold & Tilford '81]

Let T be a binary tree with n vertices. We can construct a drawing Γ of T in $\mathcal{O}(n)$ time such that:

- Γ is planar, straight-line and strictly downward
- Γ is layered: y-coordinate of vertex v is $-\text{depth}(v)$
- Horizontal and vertical distances are at least 1
- Each vertex with > 1 child is centered w.r.t. its children
- Area of Γ is in $\mathcal{O}(n^2)$ – but not optimal! ← NP-hard
- Simply isomorphic subtrees have congruent drawings, up to translation

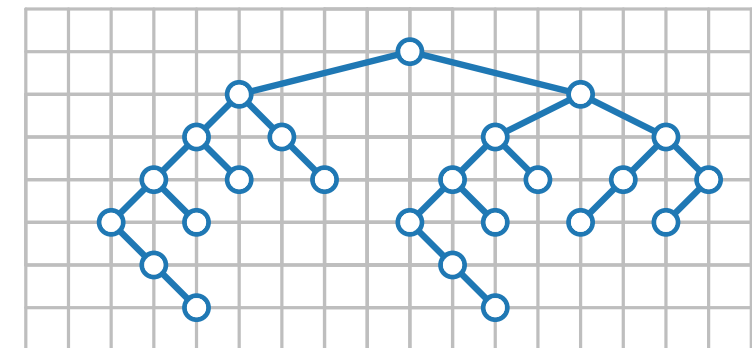
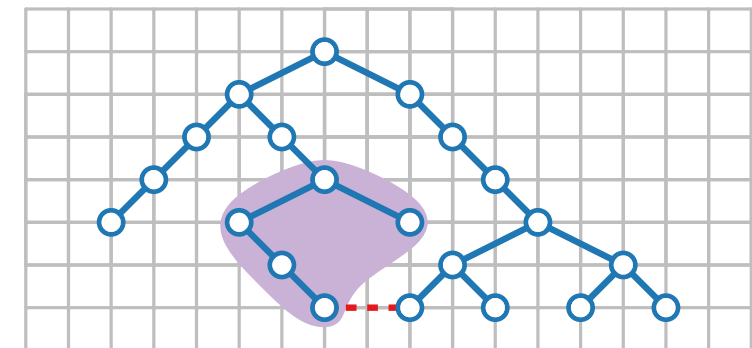
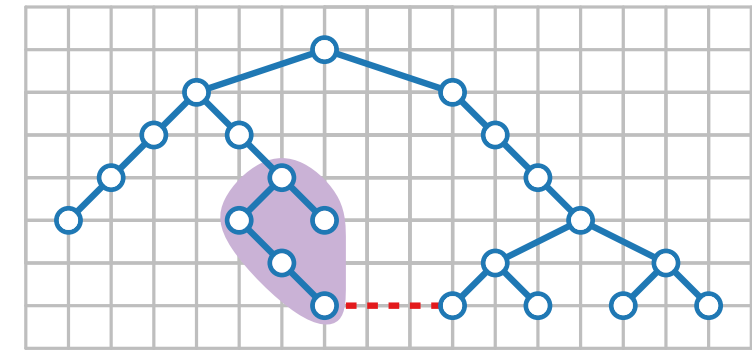

Layered Drawings – Result

Theorem.

[Reingold & Tilford '81]

Let T be a binary tree with n vertices. We can construct a drawing Γ of T in $\mathcal{O}(n)$ time such that:

- Γ is planar, straight-line and strictly downward
- Γ is layered: y-coordinate of vertex v is $-\text{depth}(v)$
- Horizontal and vertical distances are at least 1
- Each vertex with > 1 child is centered w.r.t. its children
- Area of Γ is in $\mathcal{O}(n^2)$ – but not optimal! ← NP-hard
- Simply isomorphic subtrees have congruent drawings, up to translation

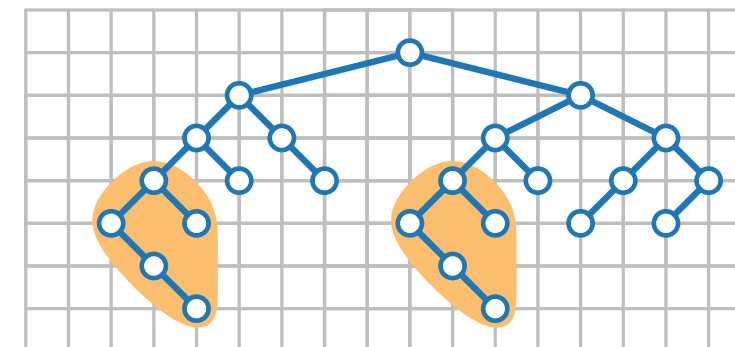
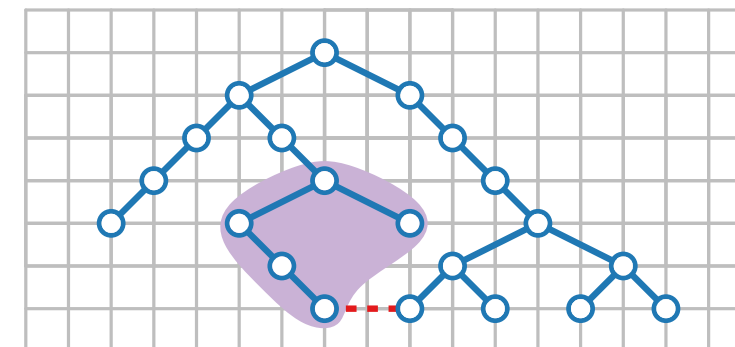
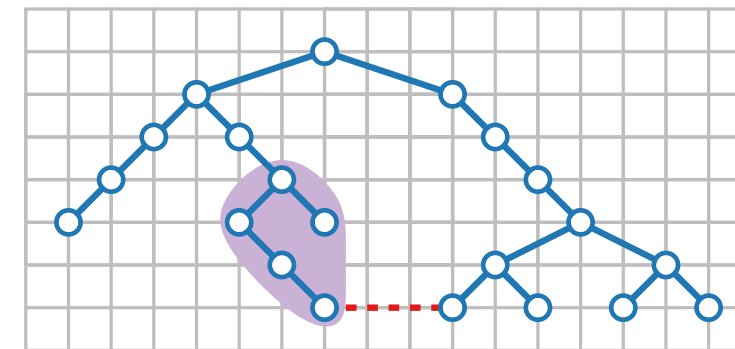

Layered Drawings – Result

Theorem.

[Reingold & Tilford '81]

Let T be a binary tree with n vertices. We can construct a drawing Γ of T in $\mathcal{O}(n)$ time such that:

- Γ is planar, straight-line and strictly downward
- Γ is layered: y-coordinate of vertex v is $-\text{depth}(v)$
- Horizontal and vertical distances are at least 1
- Each vertex with > 1 child is centered w.r.t. its children
- Area of Γ is in $\mathcal{O}(n^2)$ – but not optimal! ← NP-hard
- Simply isomorphic subtrees have congruent drawings, up to translation
- Axially isomorphic subtrees have congruent drawings, up to translation and reflection

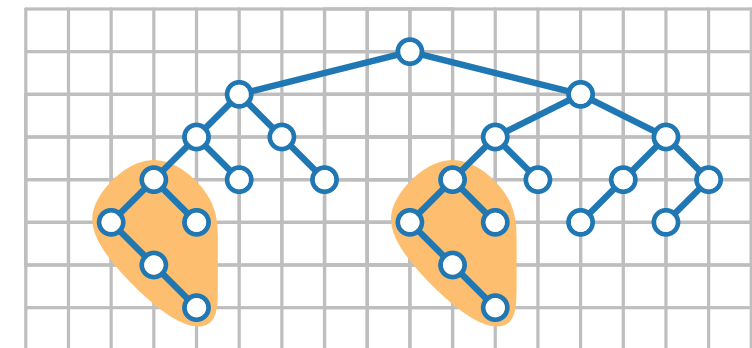
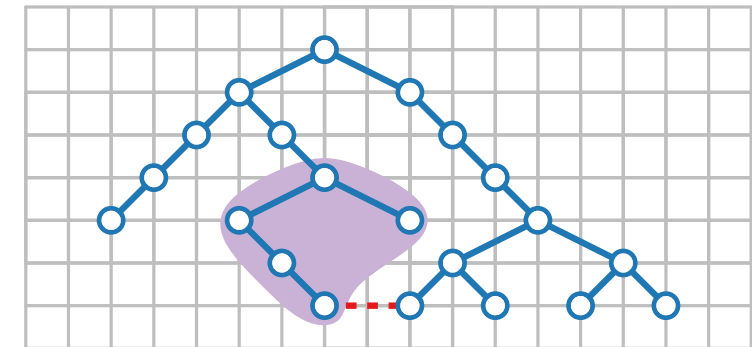
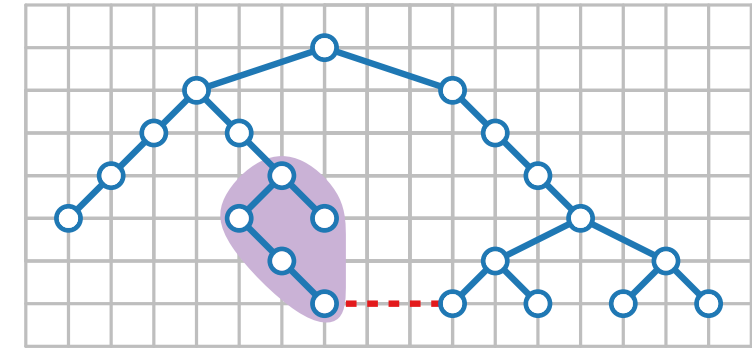

Layered Drawings – Result

Theorem.

[Reingold & Tilford '81]

Let T be a binary tree with n vertices. We can construct a drawing Γ of T in $\mathcal{O}(n)$ time such that:

- Γ is planar, straight-line and strictly downward
- Γ is layered: y-coordinate of vertex v is $-\text{depth}(v)$
- Horizontal and vertical distances are at least 1
- Each vertex with > 1 child is centered w.r.t. its children
- Area of Γ is in $\mathcal{O}(n^2)$ – but not optimal! ← NP-hard
- Simply isomorphic subtrees have congruent drawings, up to translation
- Axially isomorphic subtrees have congruent drawings, up to translation and reflection

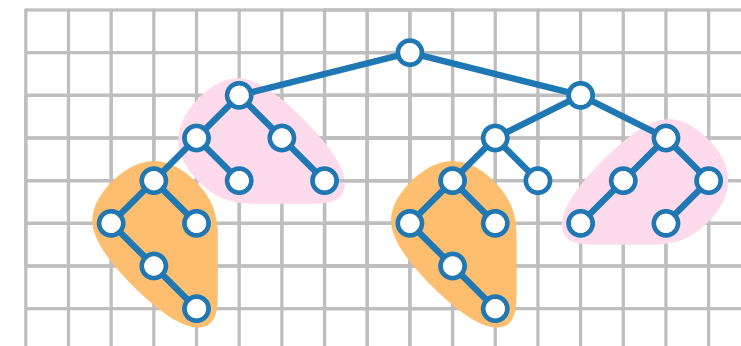
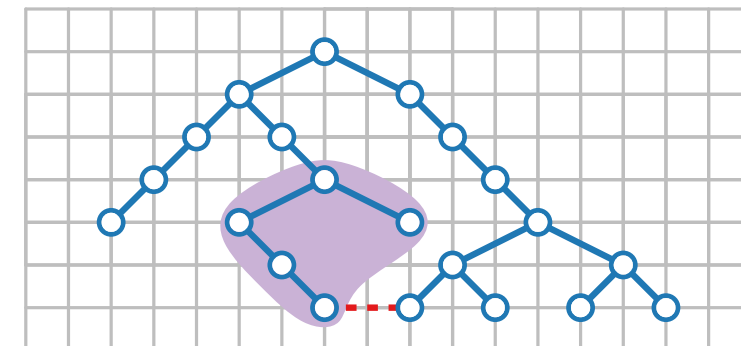
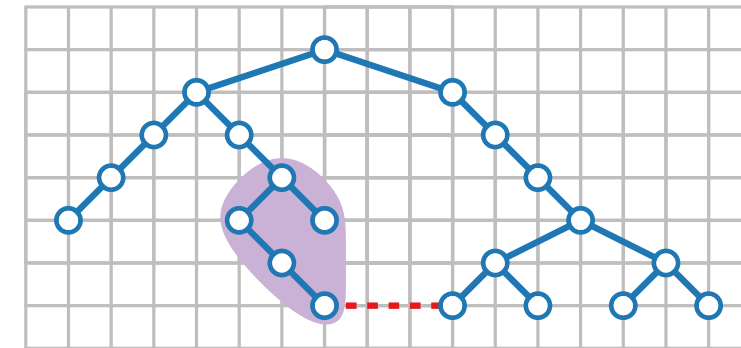

Layered Drawings – Result

Theorem. [Reingold & Tilford '81]

Let T be a ~~binary~~ ^{rooted} tree with n vertices. We can construct a drawing Γ of T in $\mathcal{O}(n)$ time such that:

- Γ is planar, straight-line and strictly downward
- Γ is layered: y-coordinate of vertex v is $-\text{depth}(v)$
- Horizontal and vertical distances are at least 1
- Each vertex with > 1 child is centered w.r.t. its children
- Area of Γ is in $\mathcal{O}(n^2)$ – but not optimal! ← NP-hard
- Simply isomorphic subtrees have congruent drawings, up to translation
- Axially isomorphic subtrees have congruent drawings, up to translation and reflection

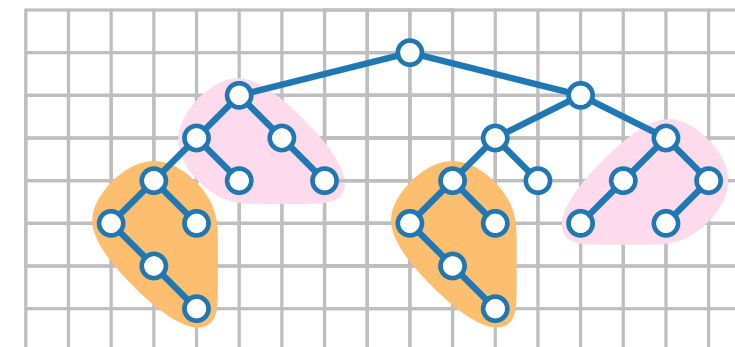
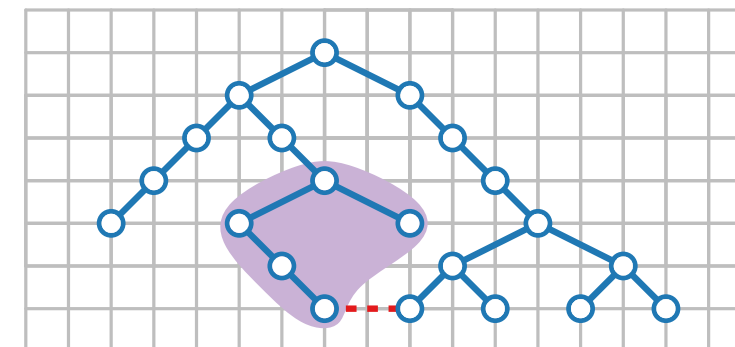
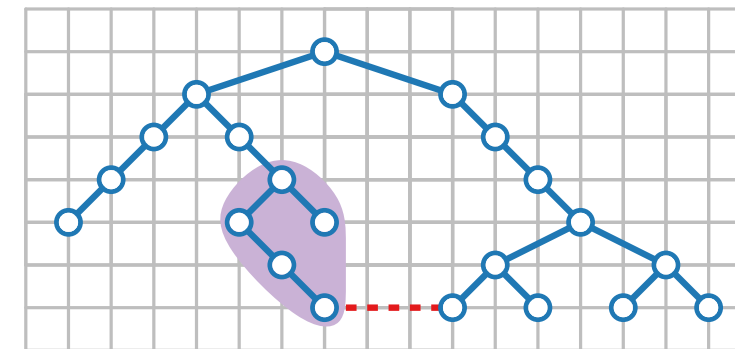

Layered Drawings – Result

Theorem. [Reingold & Tilford '81]

Let T be a ~~binary~~ ^{rooted} tree with n vertices. We can construct a drawing Γ of T in $\mathcal{O}(n)$ time such that:

- Γ is planar, straight-line and strictly downward
- Γ is layered: y-coordinate of vertex v is $-\text{depth}(v)$
- Horizontal and vertical distances are at least 1
- Each vertex with > 1 child is centered w.r.t. its children
- Area of Γ is in $\mathcal{O}(n^2)$ – but not optimal! ← NP-hard
- Simply isomorphic subtrees have congruent drawings, up to translation
- Axially isomorphic subtrees have congruent drawings, up to translation and reflection

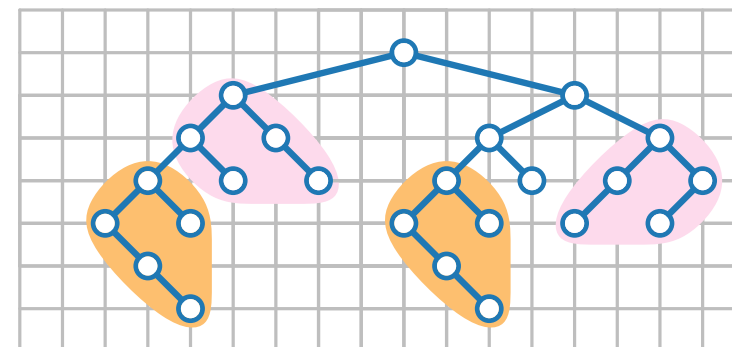
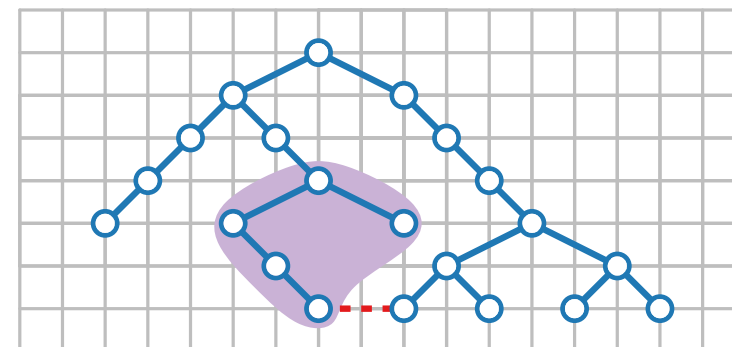
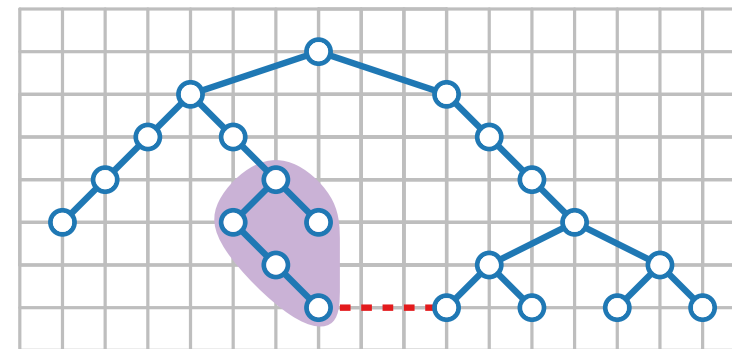

extension to non-binary rooted trees

Layered Drawings – Result

Theorem. [Reingold & Tilford '81]

Let T be a ~~binary~~ ^{rooted} tree with n vertices. We can construct a drawing Γ of T in $\mathcal{O}(n)$ time such that:

- Γ is planar, straight-line and strictly downward
- Γ is layered: y-coordinate of vertex v is $-\text{depth}(v)$
- Horizontal and vertical distances are at least 1
- Each vertex with > 1 child is centered w.r.t. its children
- Area of Γ is in $\mathcal{O}(n^2)$ – but not optimal! ← NP-hard
- Simply isomorphic subtrees have congruent drawings, up to translation
- Axially isomorphic subtrees have congruent drawings, up to translation and reflection

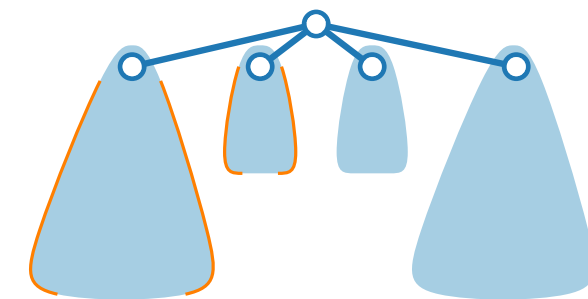
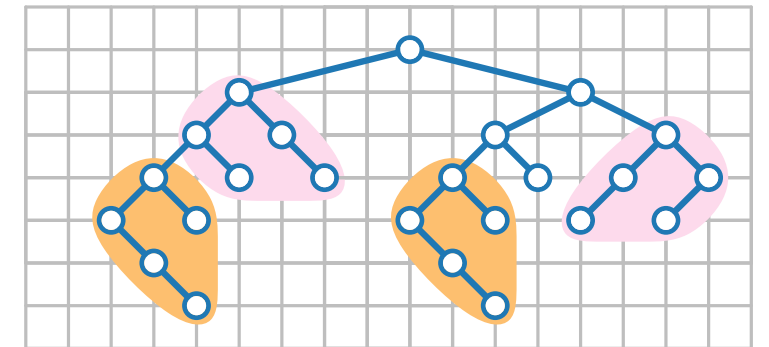
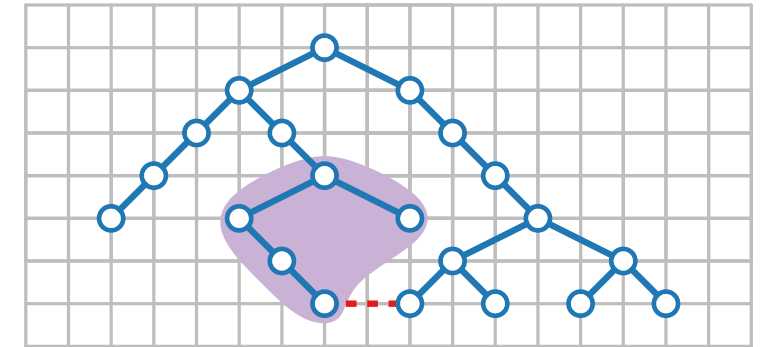
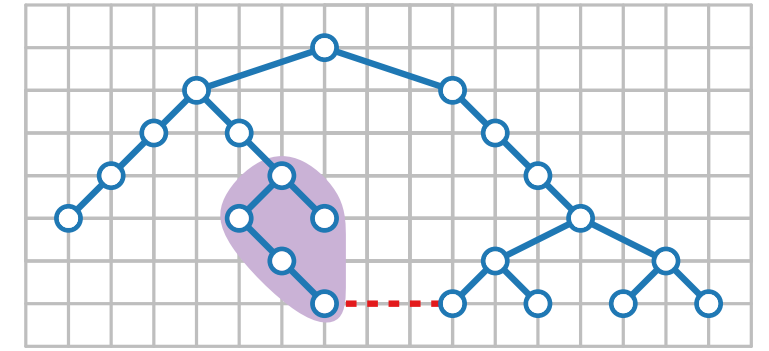

extension to non-binary rooted trees

Layered Drawings – Result

Theorem. [Reingold & Tilford '81]

Let T be a ~~binary~~ ^{rooted} tree with n vertices. We can construct a drawing Γ of T in $\mathcal{O}(n)$ time such that:

- Γ is planar, straight-line and strictly downward
- Γ is layered: y-coordinate of vertex v is $-\text{depth}(v)$
- Horizontal and vertical distances are at least 1
- Each vertex with > 1 child is centered w.r.t. its children
- Area of Γ is in $\mathcal{O}(n^2)$ – but not optimal! ← NP-hard
- Simply isomorphic subtrees have congruent drawings, up to translation
- Axially isomorphic subtrees have congruent drawings, up to translation and reflection

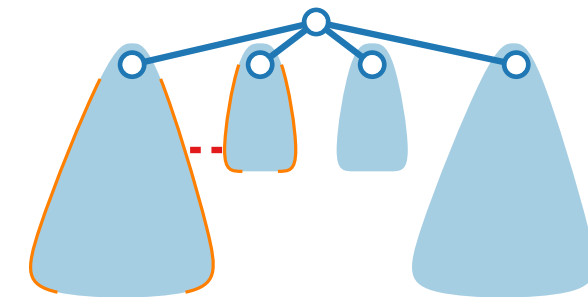
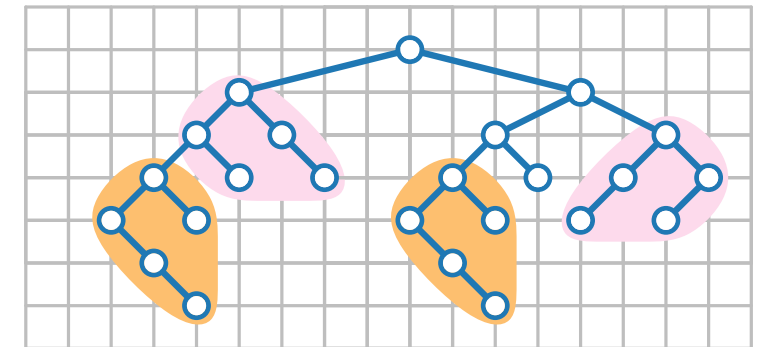
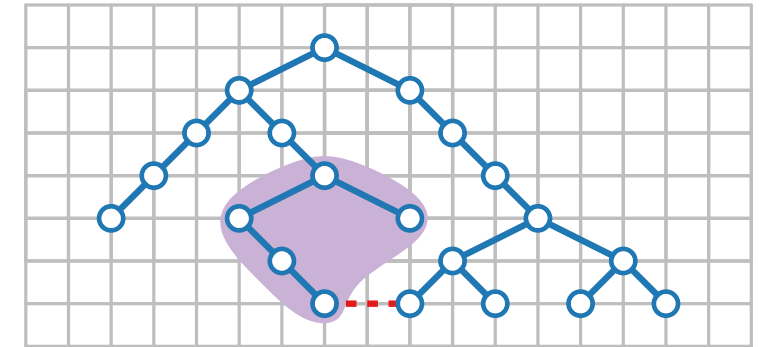
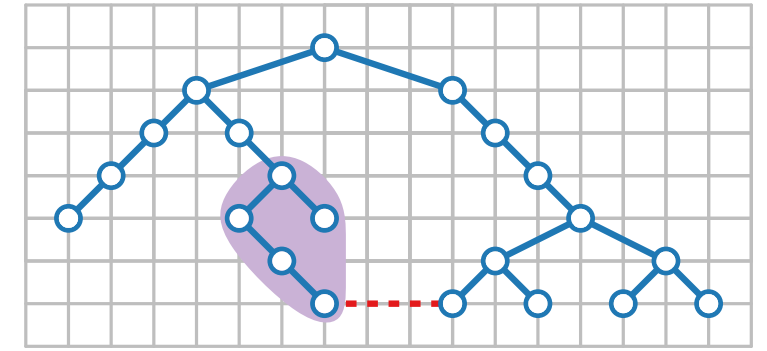

extension to non-binary rooted trees

Layered Drawings – Result

Theorem. [Reingold & Tilford '81]

Let T be a ~~binary~~ ^{rooted} tree with n vertices. We can construct a drawing Γ of T in $\mathcal{O}(n)$ time such that:

- Γ is planar, straight-line and strictly downward
- Γ is layered: y-coordinate of vertex v is $-\text{depth}(v)$
- Horizontal and vertical distances are at least 1
- Each vertex with > 1 child is centered w.r.t. its children
- Area of Γ is in $\mathcal{O}(n^2)$ – but not optimal! ← NP-hard
- Simply isomorphic subtrees have congruent drawings, up to translation
- Axially isomorphic subtrees have congruent drawings, up to translation and reflection

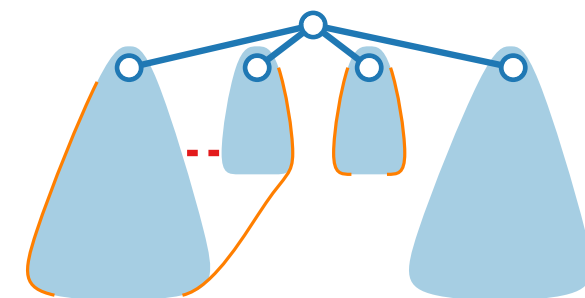
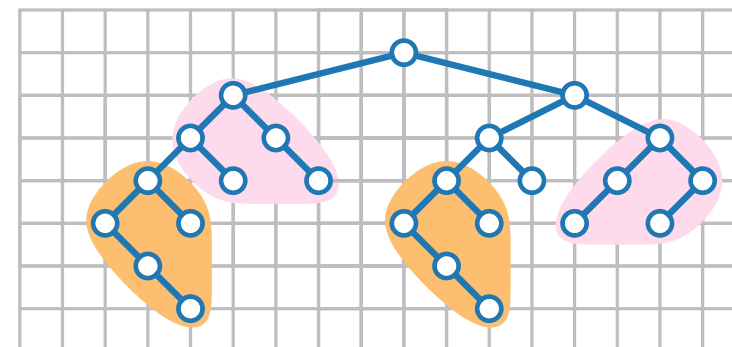
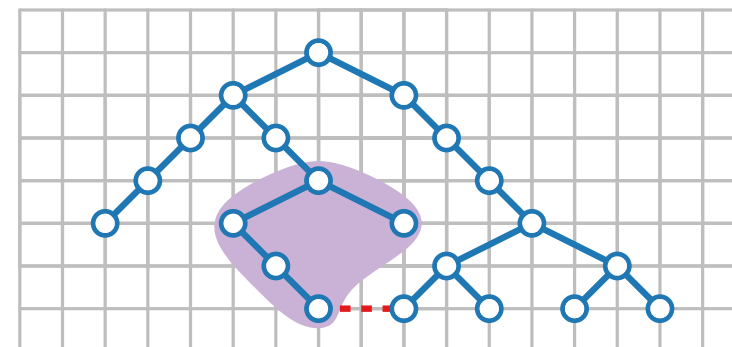
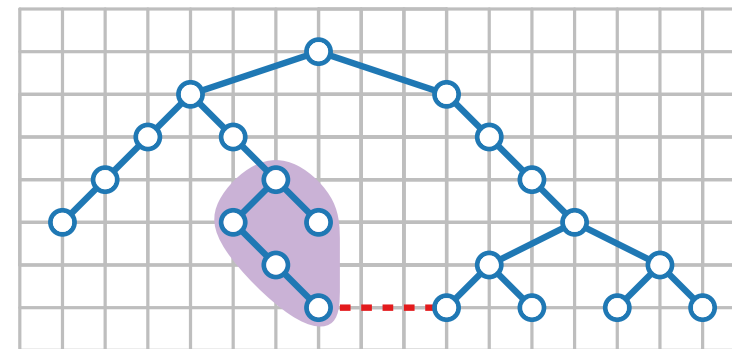

extension to non-binary rooted trees

Layered Drawings – Result

Theorem. [Reingold & Tilford '81]

Let T be a ~~binary~~ ^{rooted} tree with n vertices. We can construct a drawing Γ of T in $\mathcal{O}(n)$ time such that:

- Γ is planar, straight-line and strictly downward
- Γ is layered: y-coordinate of vertex v is $-\text{depth}(v)$
- Horizontal and vertical distances are at least 1
- Each vertex with > 1 child is centered w.r.t. its children
- Area of Γ is in $\mathcal{O}(n^2)$ – but not optimal! ← NP-hard
- Simply isomorphic subtrees have congruent drawings, up to translation
- Axially isomorphic subtrees have congruent drawings, up to translation and reflection

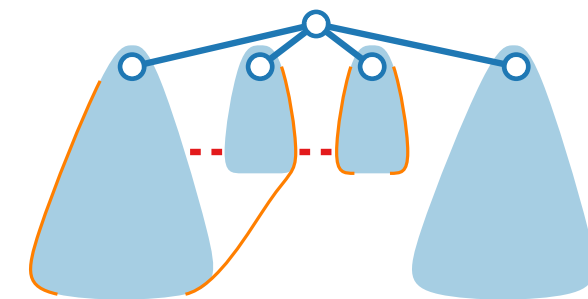
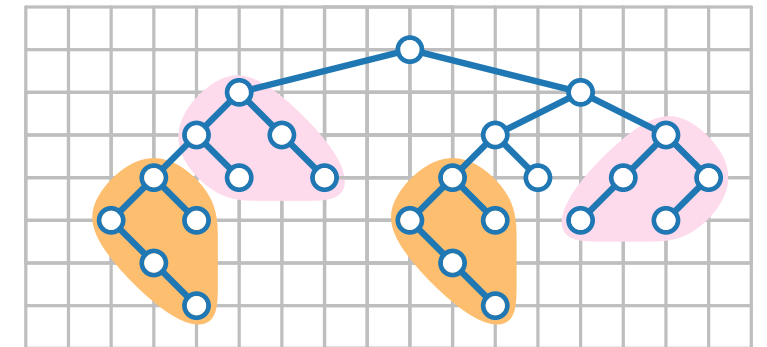
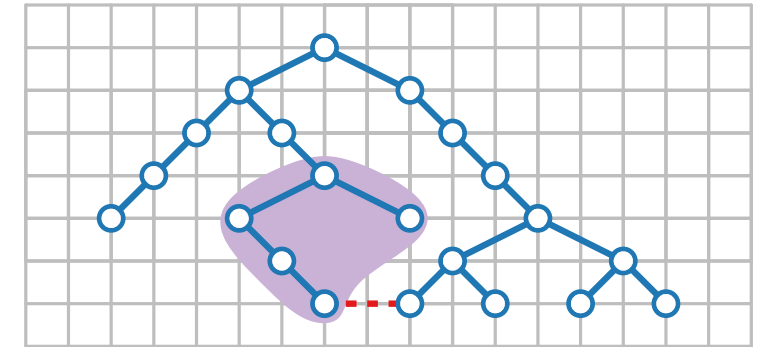
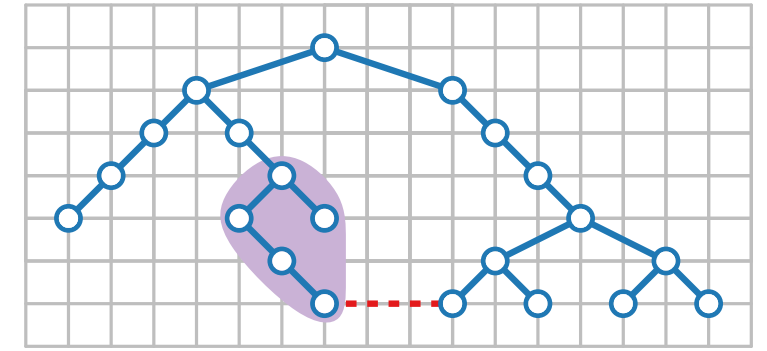

extension to non-binary rooted trees

Layered Drawings – Result

Theorem. [Reingold & Tilford '81]

Let T be a ~~binary~~ ^{rooted} tree with n vertices. We can construct a drawing Γ of T in $\mathcal{O}(n)$ time such that:

- Γ is planar, straight-line and strictly downward
- Γ is layered: y-coordinate of vertex v is $-\text{depth}(v)$
- Horizontal and vertical distances are at least 1
- Each vertex with > 1 child is centered w.r.t. its children
- Area of Γ is in $\mathcal{O}(n^2)$ – but not optimal! ← NP-hard
- Simply isomorphic subtrees have congruent drawings, up to translation
- Axially isomorphic subtrees have congruent drawings, up to translation and reflection

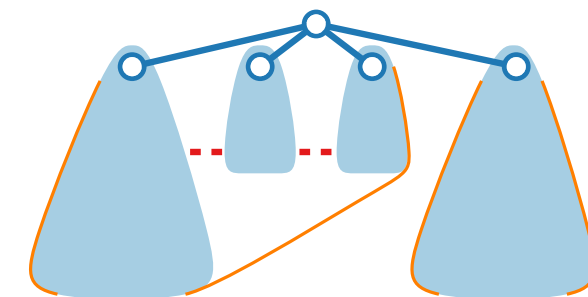
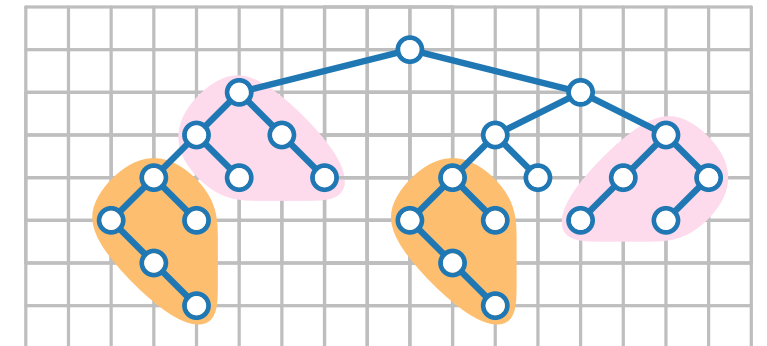
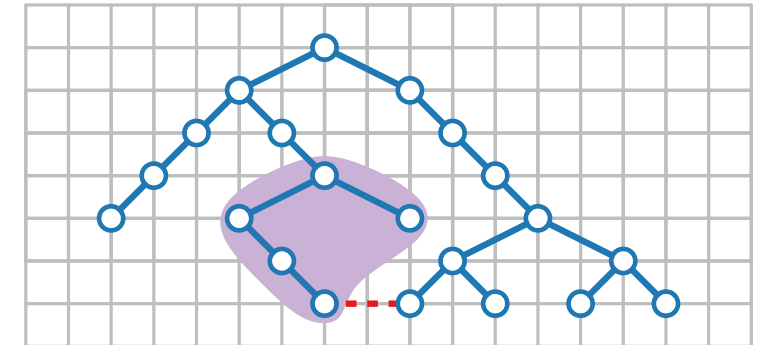
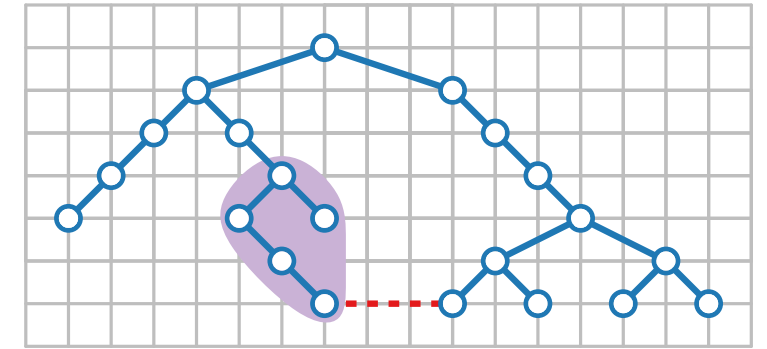

extension to non-binary rooted trees

Layered Drawings – Result

Theorem. [Reingold & Tilford '81]

Let T be a ~~binary~~ ^{rooted} tree with n vertices. We can construct a drawing Γ of T in $\mathcal{O}(n)$ time such that:

- Γ is planar, straight-line and strictly downward
- Γ is layered: y-coordinate of vertex v is $-\text{depth}(v)$
- Horizontal and vertical distances are at least 1
- Each vertex with > 1 child is centered w.r.t. its children
- Area of Γ is in $\mathcal{O}(n^2)$ – but not optimal! ← NP-hard
- Simply isomorphic subtrees have congruent drawings, up to translation
- Axially isomorphic subtrees have congruent drawings, up to translation and reflection

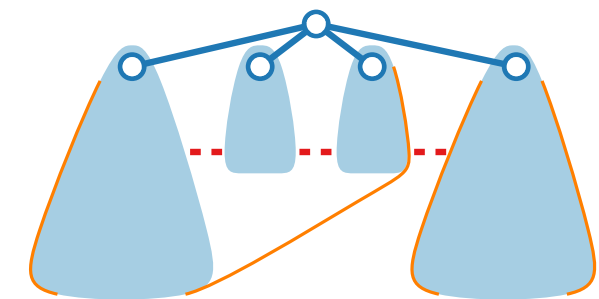
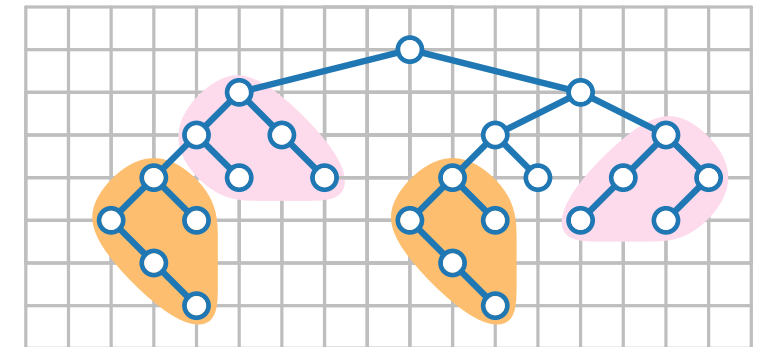
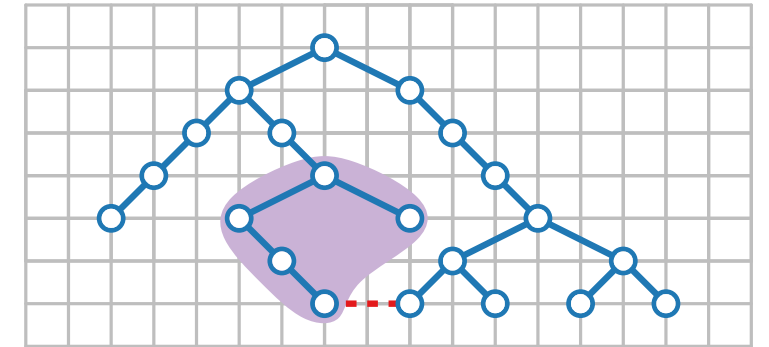
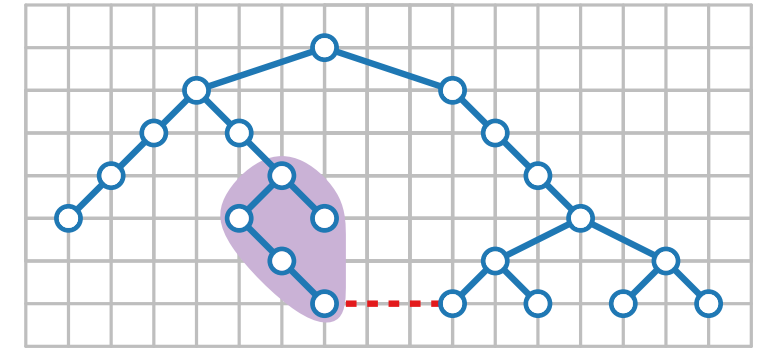

extension to non-binary rooted trees

Layered Drawings – Result

Theorem. ~~rooted~~ [Reingold & Tilford '81]

Let T be a ~~binary~~ tree with n vertices. We can construct a drawing Γ of T in $\mathcal{O}(n)$ time such that:

- Γ is planar, straight-line and strictly downward
- Γ is layered: y-coordinate of vertex v is $-\text{depth}(v)$
- Horizontal and vertical distances are at least 1
- Each vertex with > 1 child is centered w.r.t. its children
- Area of Γ is in $\mathcal{O}(n^2)$ – but not optimal! ← NP-hard
- Simply isomorphic subtrees have congruent drawings, up to translation
- Axially isomorphic subtrees have congruent drawings, up to translation and reflection

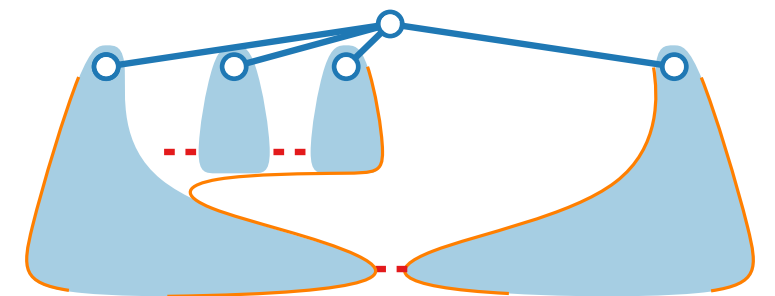
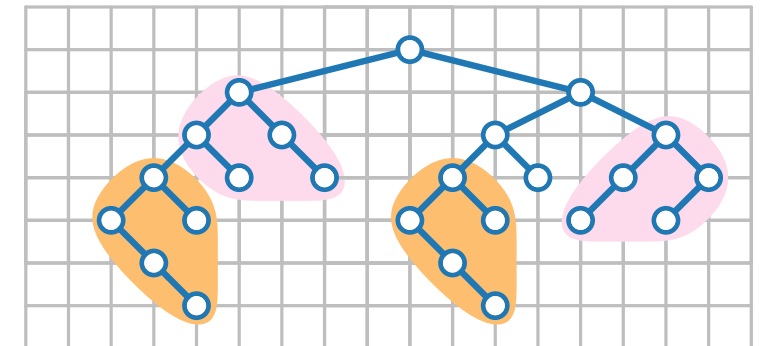
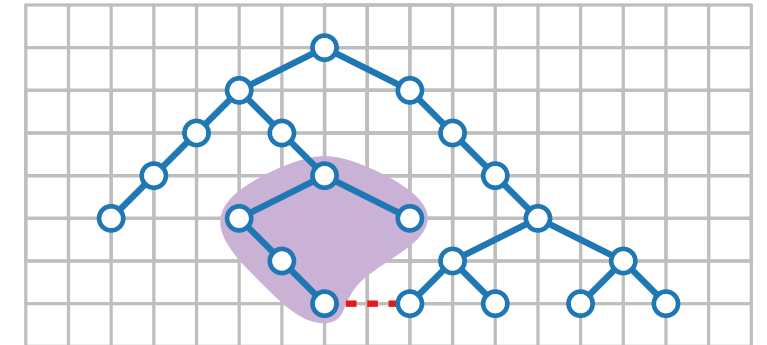
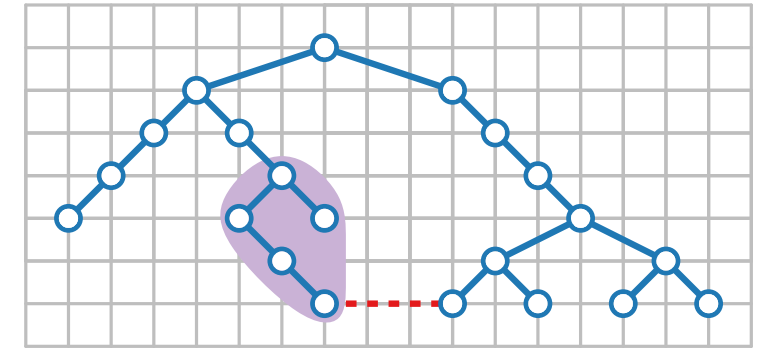

extension to non-binary rooted trees

Layered Drawings – Result

Theorem. [Reingold & Tilford '81]

Let T be a ~~binary~~ ^{rooted} tree with n vertices. We can construct a drawing Γ of T in $\mathcal{O}(n)$ time such that:

- Γ is planar, straight-line and strictly downward
- Γ is layered: y-coordinate of vertex v is $-\text{depth}(v)$
- Horizontal and vertical distances are at least 1
- Each vertex with > 1 child is centered w.r.t. its children
- Area of Γ is in $\mathcal{O}(n^2)$ – but not optimal! ← NP-hard
- Simply isomorphic subtrees have congruent drawings, up to translation
- ~~■ Axially isomorphic subtrees have congruent drawings, up to translation and reflection~~

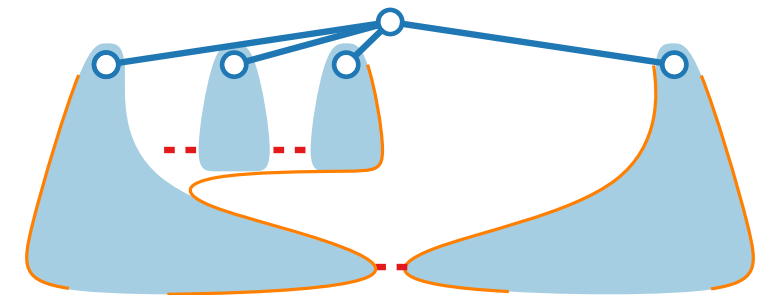
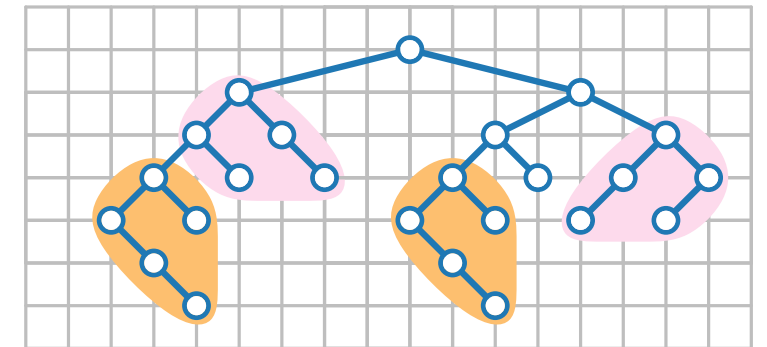
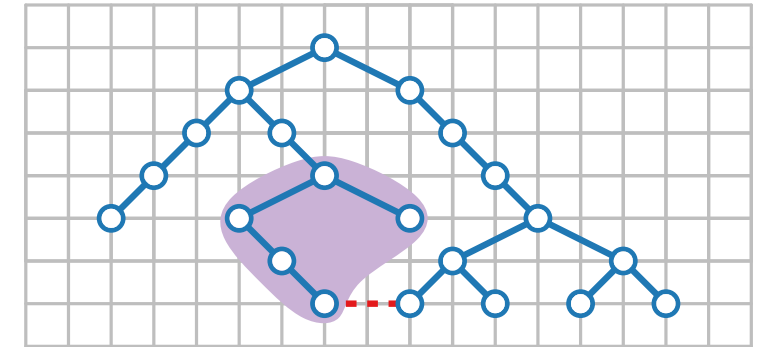
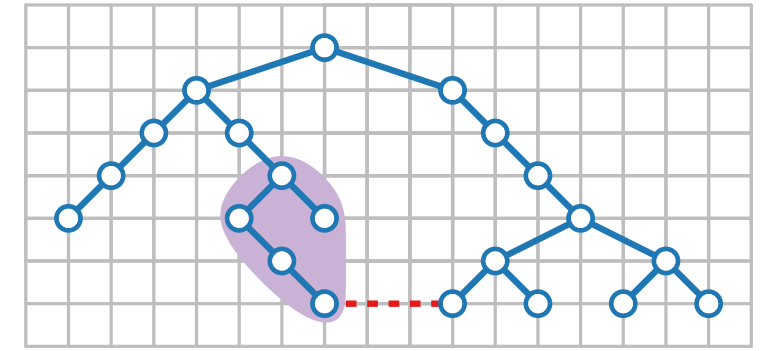

extension to non-binary rooted trees

Visualization of Graphs

Lecture 1: Drawing Trees

Part II: HV-Drawings

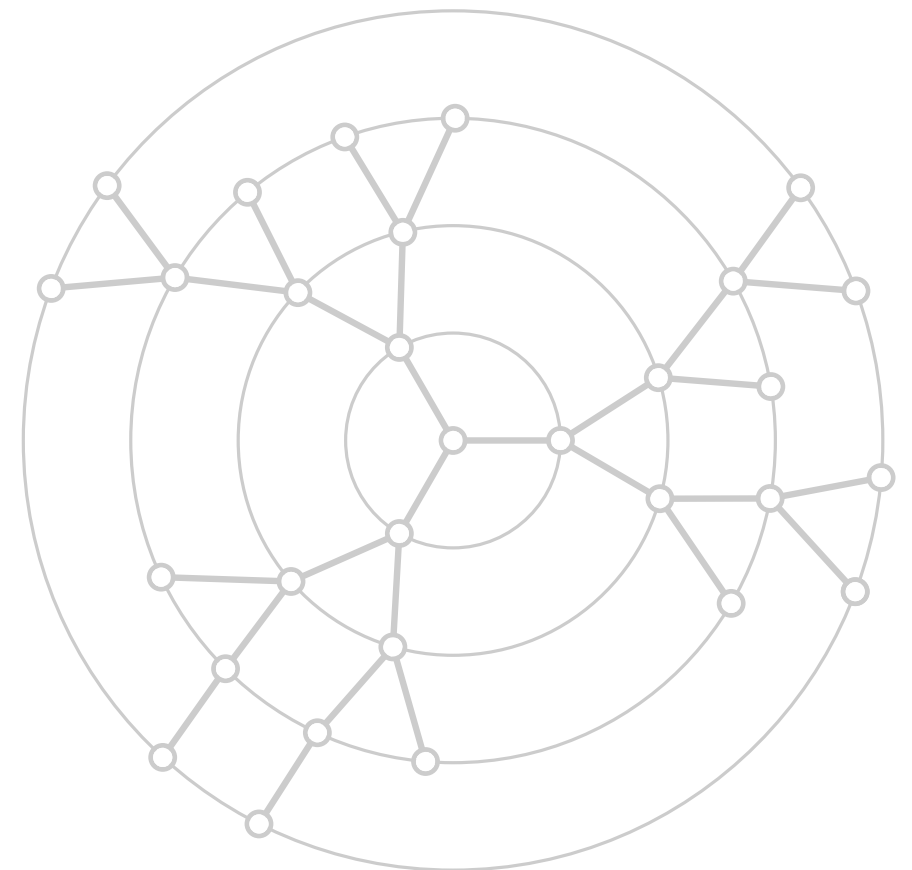
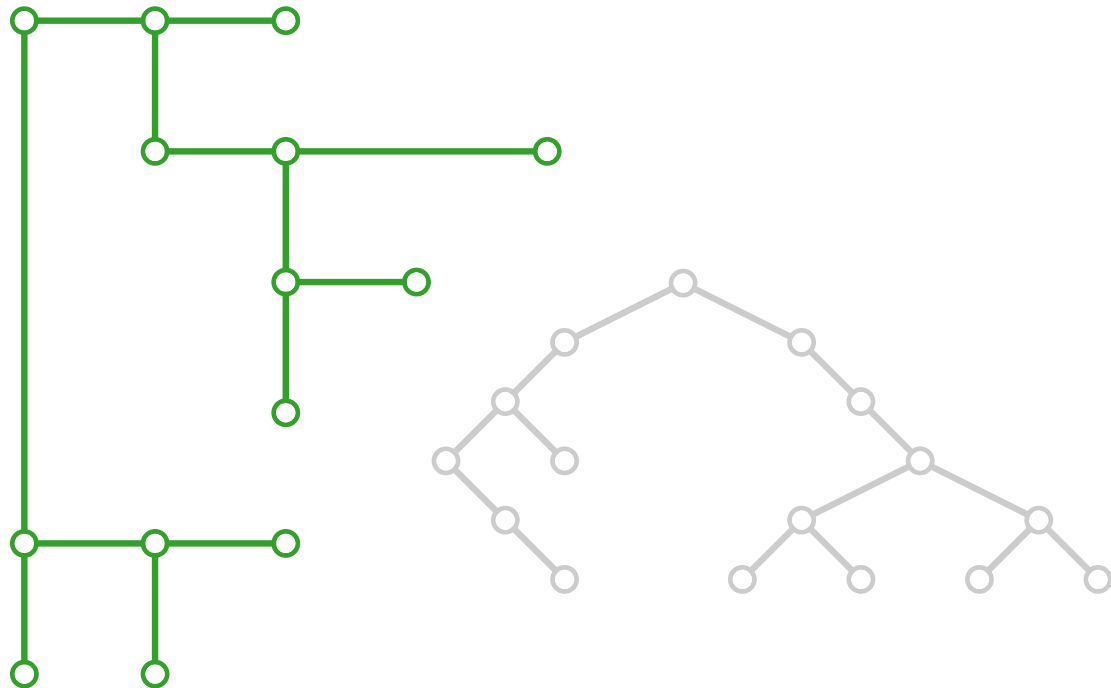

HV-Drawings – Drawing Style

Applications

- Cons cell diagram in LISP

HV-Drawings – Drawing Style

Applications

- Cons cell diagram in LISP
- *Cons* (constructs) are memory objects that hold two values or pointers to values

HV-Drawings – Drawing Style

Applications

- Cons cell diagram in LISP
- *Cons* (constructs) are memory objects that hold two values or pointers to values

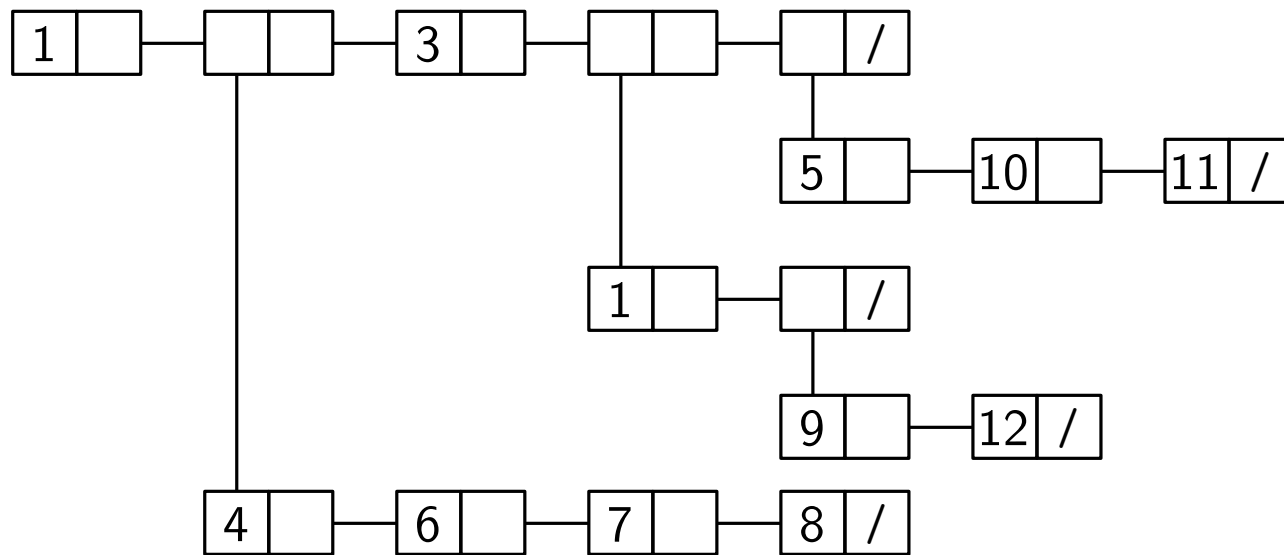

Source: after gajon.org/trees-linked-lists-common-lisp/

HV-Drawings – Drawing Style

Applications

- Cons cell diagram in LISP
- *Cons* (constructs) are memory objects that hold two values or pointers to values

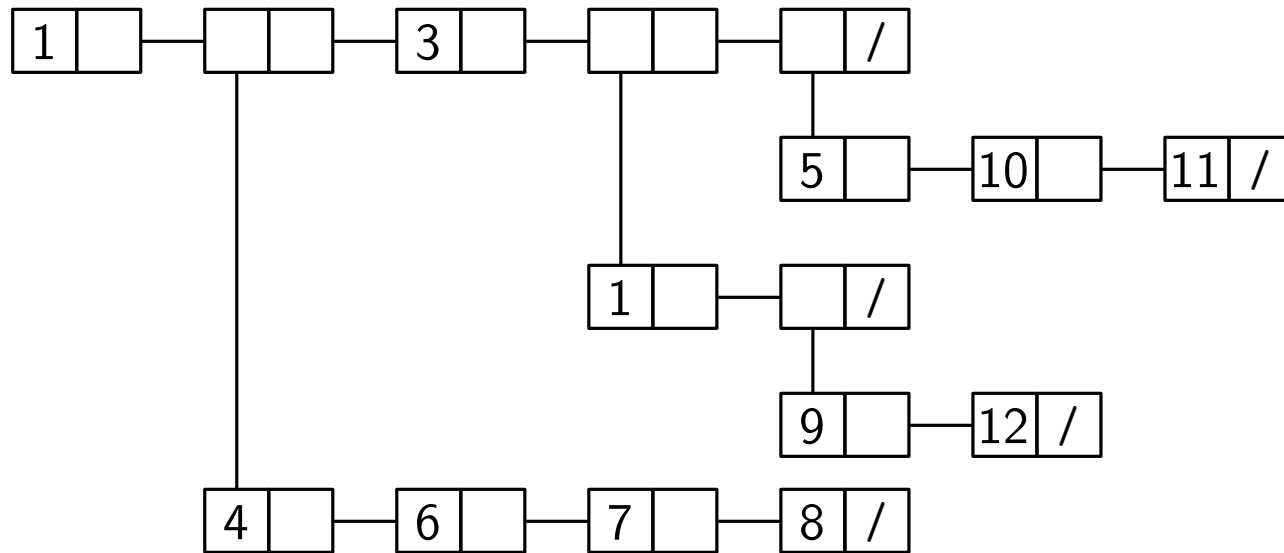

Source: after gajon.org/trees-linked-lists-common-lisp/

Drawing conventions

Drawing aesthetics to optimize

HV-Drawings – Drawing Style

Applications

- Cons cell diagram in LISP
- *Cons* (constructs) are memory objects that hold two values or pointers to values

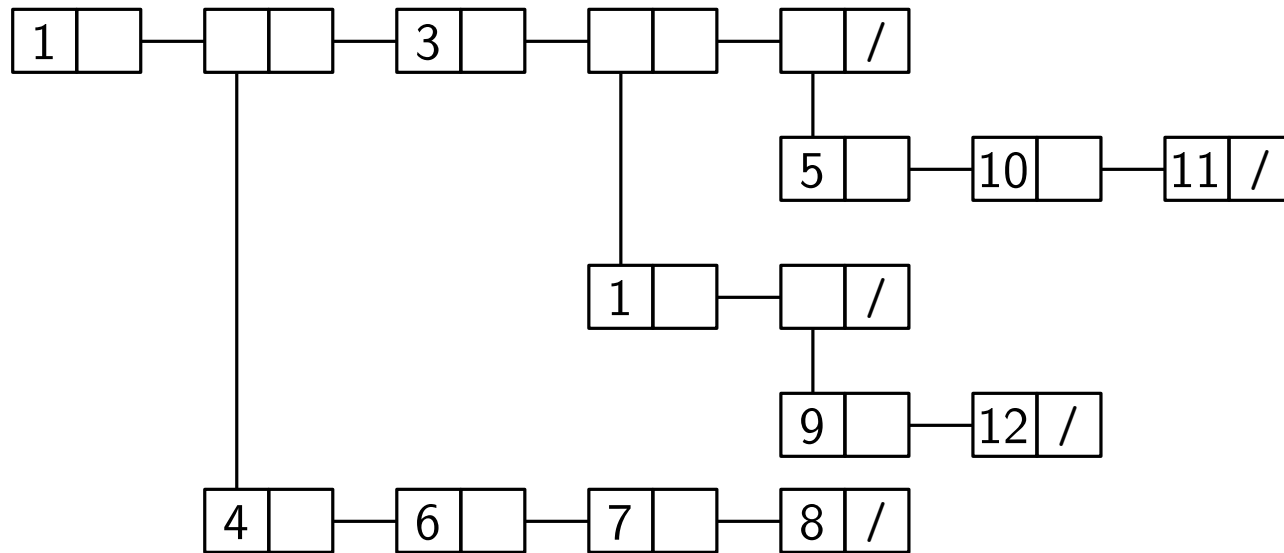

Source: after gajon.org/trees-linked-lists-common-lisp/

Drawing conventions

- Children are vertically or horizontally aligned with their parent

Drawing aesthetics to optimize

HV-Drawings – Drawing Style

Applications

- Cons cell diagram in LISP
- *Cons* (constructs) are memory objects that hold two values or pointers to values

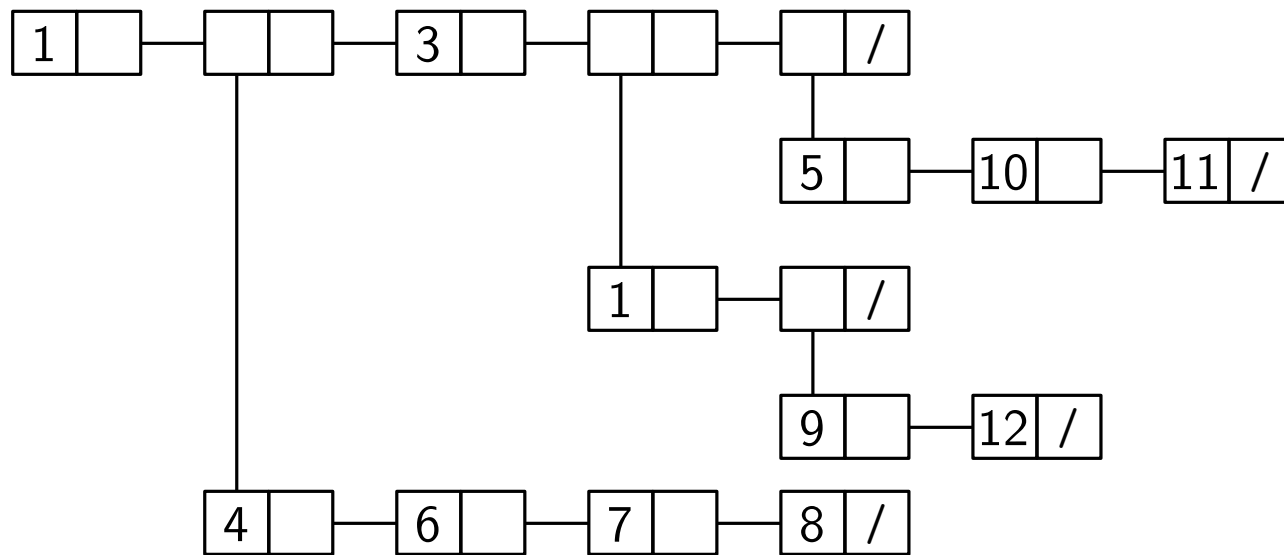

Source: after gajon.org/trees-linked-lists-common-lisp/

Drawing conventions

- Children are vertically or horizontally aligned with their parent
- The bounding boxes of the subtrees of the children are disjoint

Drawing aesthetics to optimize

HV-Drawings – Drawing Style

Applications

- Cons cell diagram in LISP
- *Cons* (constructs) are memory objects that hold two values or pointers to values

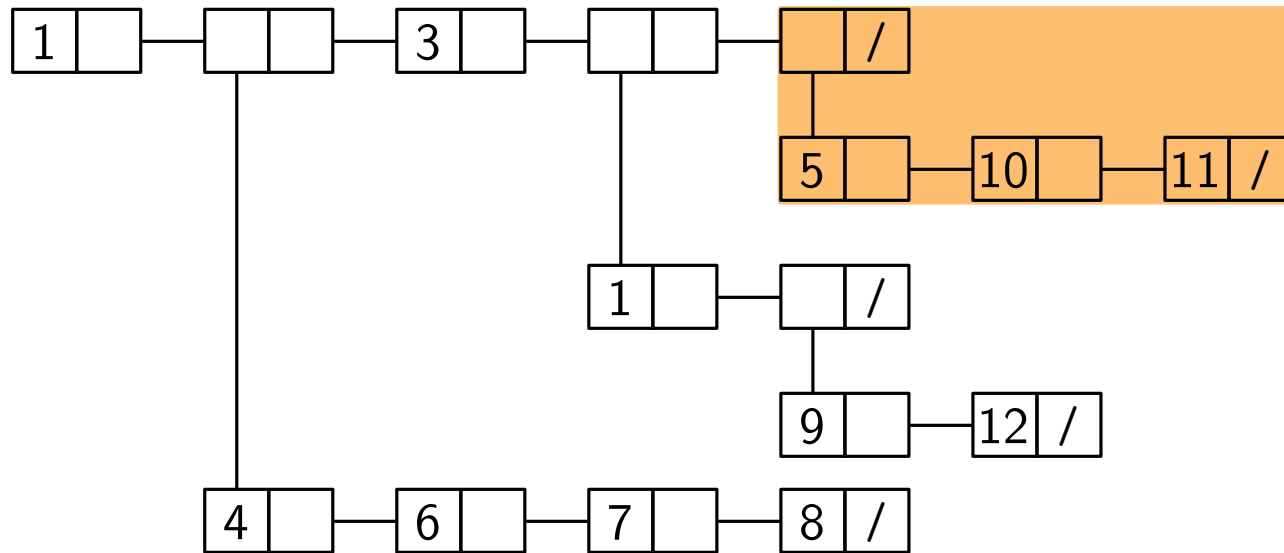

Source: after gajon.org/trees-linked-lists-common-lisp/

Drawing conventions

- Children are vertically or horizontally aligned with their parent
- The bounding boxes of the subtrees of the children are disjoint

Drawing aesthetics to optimize

HV-Drawings – Drawing Style

Applications

- Cons cell diagram in LISP
- *Cons* (constructs) are memory objects that hold two values or pointers to values

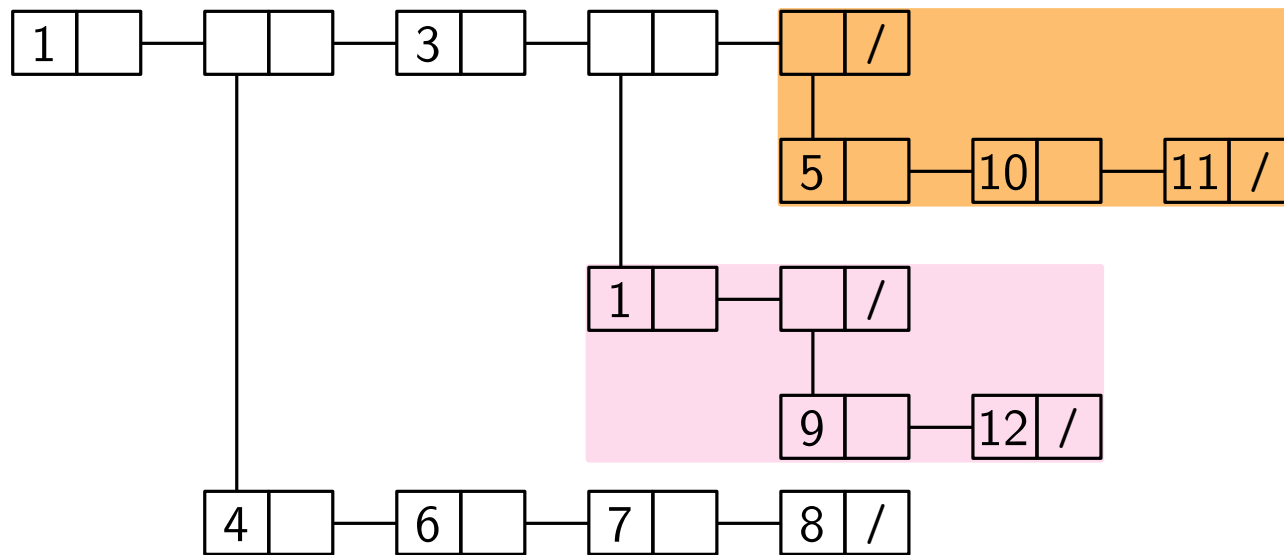

Source: after gajon.org/trees-linked-lists-common-lisp/

Drawing conventions

- Children are vertically or horizontally aligned with their parent
- The bounding boxes of the subtrees of the children are disjoint

Drawing aesthetics to optimize

HV-Drawings – Drawing Style

Applications

- Cons cell diagram in LISP
- *Cons* (constructs) are memory objects that hold two values or pointers to values

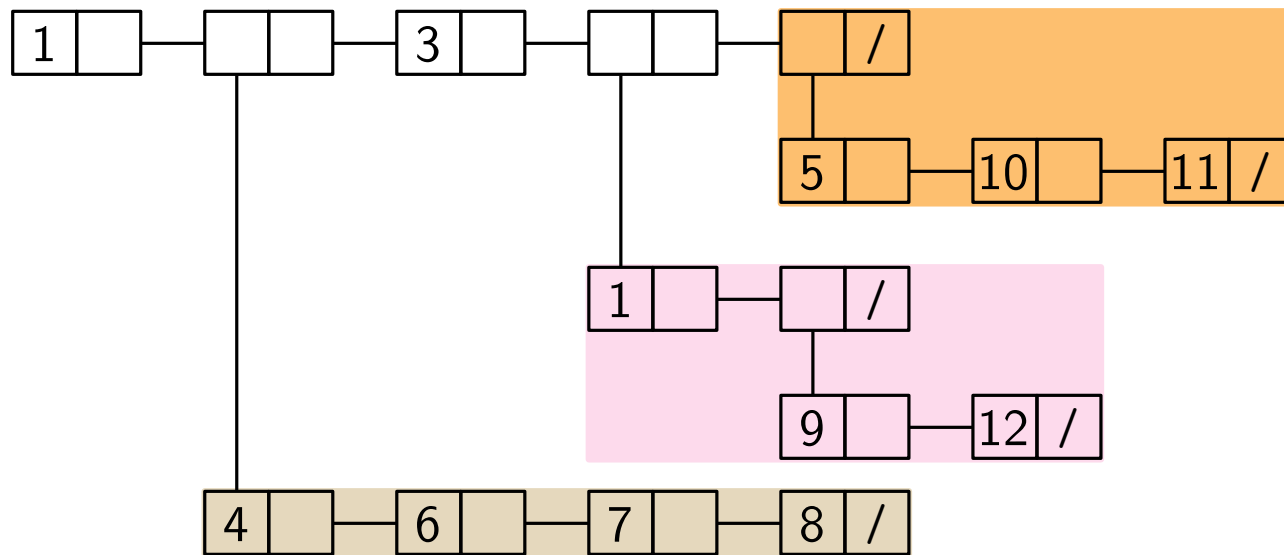

Source: after gajon.org/trees-linked-lists-common-lisp/

Drawing conventions

- Children are vertically or horizontally aligned with their parent
- The bounding boxes of the subtrees of the children are disjoint

Drawing aesthetics to optimize

HV-Drawings – Drawing Style

Applications

- Cons cell diagram in LISP
- *Cons* (constructs) are memory objects that hold two values or pointers to values

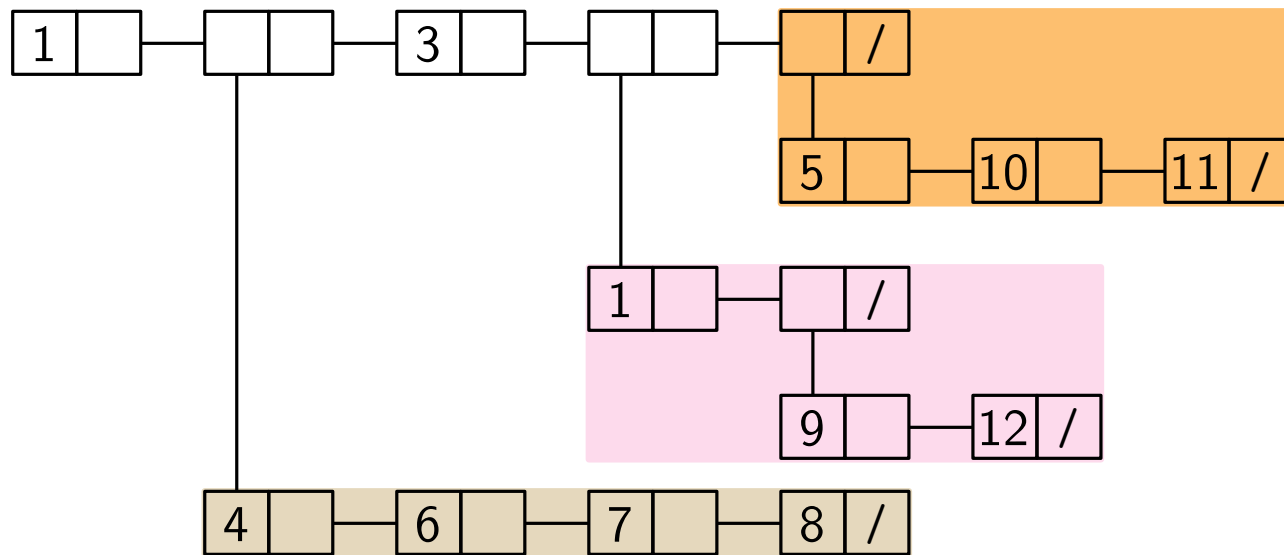

Source: after gajon.org/trees-linked-lists-common-lisp/

Drawing conventions

- Children are vertically or horizontally aligned with their parent
- The bounding boxes of the subtrees of the children are disjoint
- Edges are strictly down- or rightwards

Drawing aesthetics to optimize

HV-Drawings – Drawing Style

Applications

- Cons cell diagram in LISP
- *Cons* (constructs) are memory objects that hold two values or pointers to values

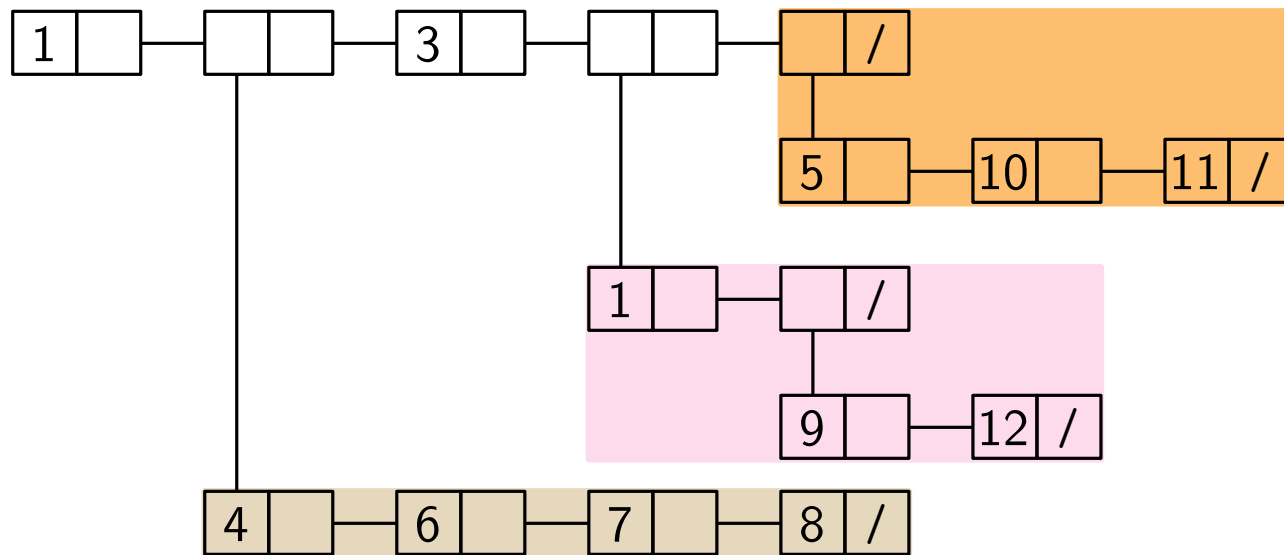

Source: after gajon.org/trees-linked-lists-common-lisp/

Drawing conventions

- Children are vertically or horizontally aligned with their parent
- The bounding boxes of the subtrees of the children are disjoint
- Edges are strictly down- or rightwards

Drawing aesthetics to optimize

- Height, width, area

HV-Drawings – Algorithm

Input: A binary tree T

Output: An HV-drawing of T

HV-Drawings – Algorithm

Input: A binary tree T

Output: An HV-drawing of T

Base case: 

HV-Drawings – Algorithm

Input: A binary tree T

Output: An HV-drawing of T

Base case: 

Divide: Recursively apply the algorithm to draw the left and right subtrees

HV-Drawings – Algorithm

Input: A binary tree T

Output: An HV-drawing of T

Base case: 

Divide: Recursively apply the algorithm to draw the left and right subtrees

Conquer:

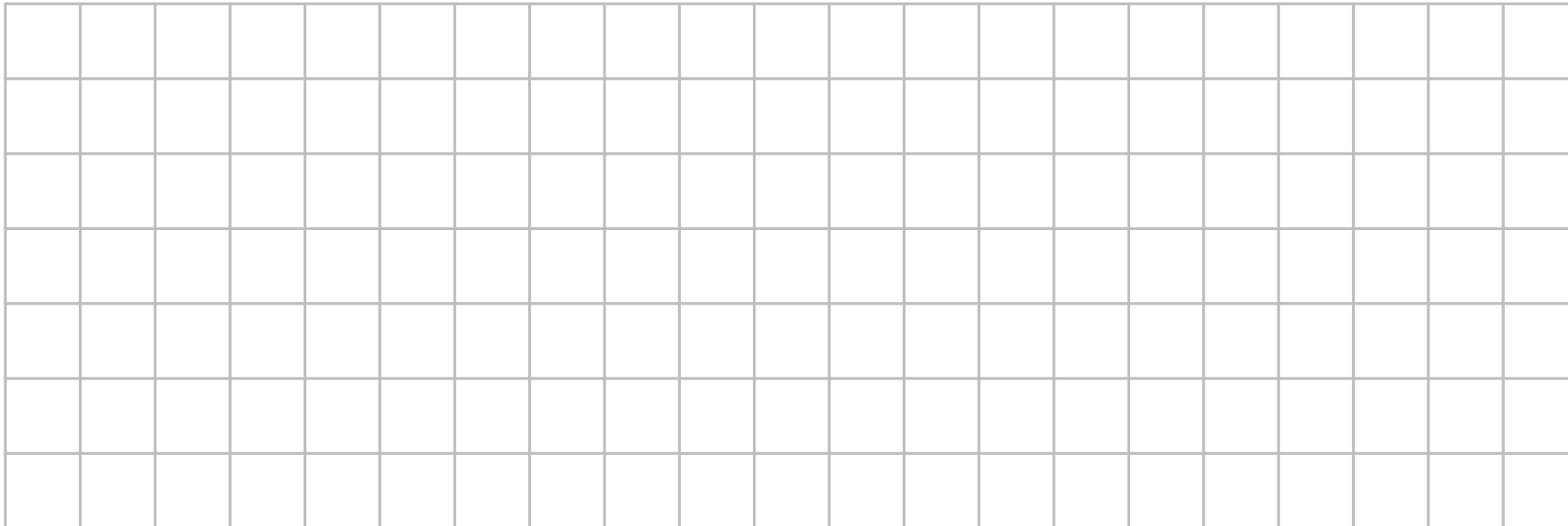

HV-Drawings – Algorithm

Input: A binary tree T

Output: An HV-drawing of T

Base case: 

Divide: Recursively apply the algorithm to draw the left and right subtrees

Conquer:

horizontal combination

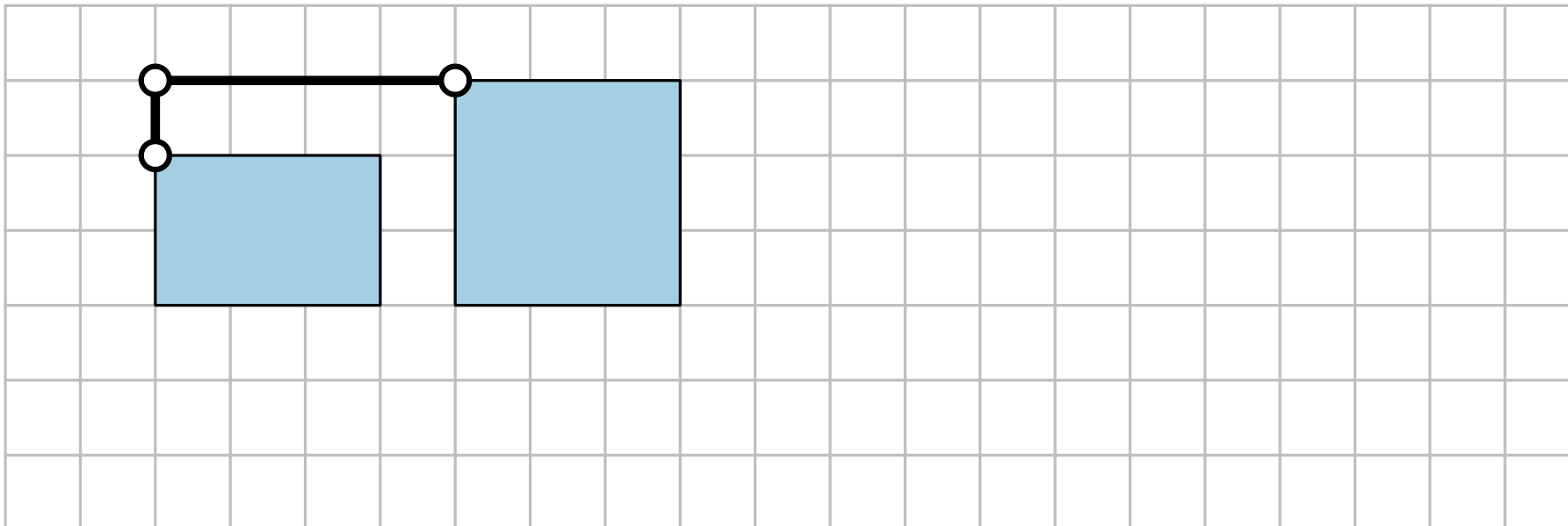

HV-Drawings – Algorithm

Input: A binary tree T

Output: An HV-drawing of T

Base case: 

Divide: Recursively apply the algorithm to draw the left and right subtrees

Conquer:

horizontal combination

vertical combination

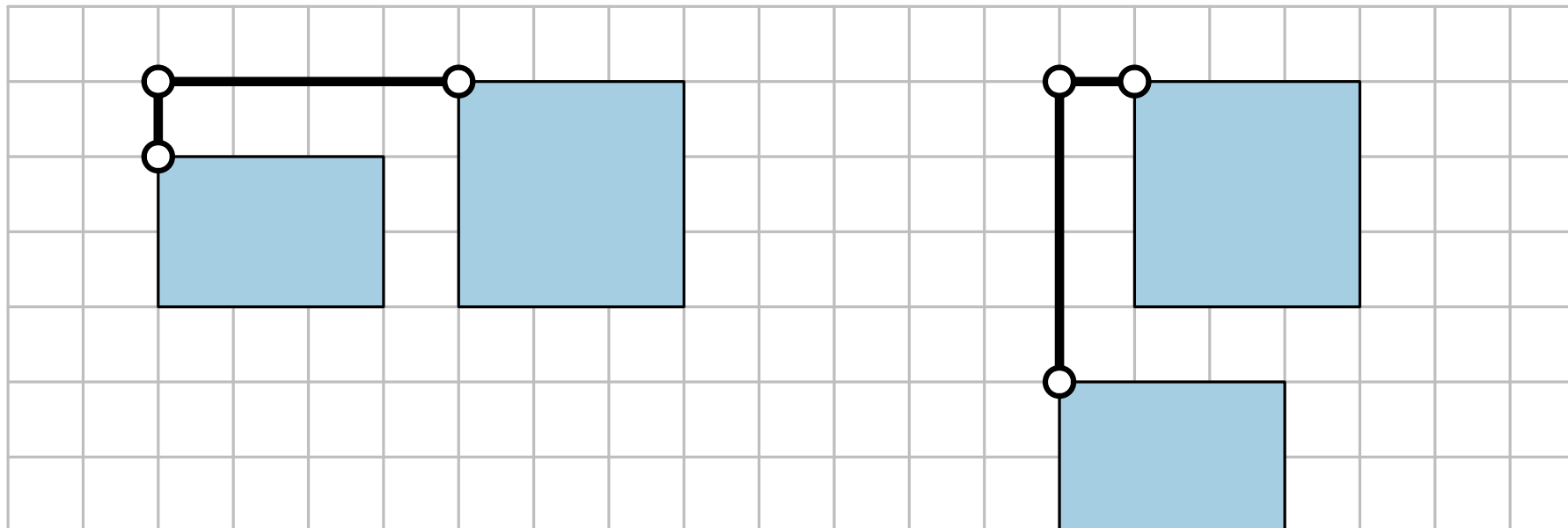

HV-Drawings – Right-Heavy HV-Layout

Right-heavy approach

- Always apply horizontal combination

HV-Drawings – Right-Heavy HV-Layout

Right-heavy approach

- Always apply horizontal combination
- Place the larger subtree to the right

HV-Drawings – Right-Heavy HV-Layout

Right-heavy approach

- Always apply horizontal combination
- Place the larger subtree to the right ← *This can change the embedding!*

HV-Drawings – Right-Heavy HV-Layout

Right-heavy approach

- Always apply horizontal combination
- Place the larger subtree to the right ← *This can change the embedding!*
Size of subtree := number of vertices

HV-Drawings – Right-Heavy HV-Layout

Right-heavy approach

- Always apply horizontal combination
- Place the larger subtree to the right ← *This can change the embedding!*
Size of subtree := number of vertices

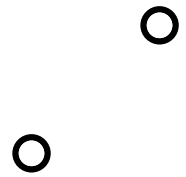

HV-Drawings – Right-Heavy HV-Layout

Right-heavy approach

- Always apply horizontal combination
- Place the larger subtree to the right ← *This can change the embedding!*
Size of subtree := number of vertices

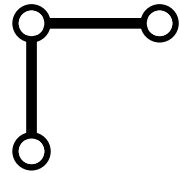

HV-Drawings – Right-Heavy HV-Layout

Right-heavy approach

- Always apply horizontal combination
- Place the larger subtree to the right ← *This can change the embedding!*
Size of subtree := number of vertices

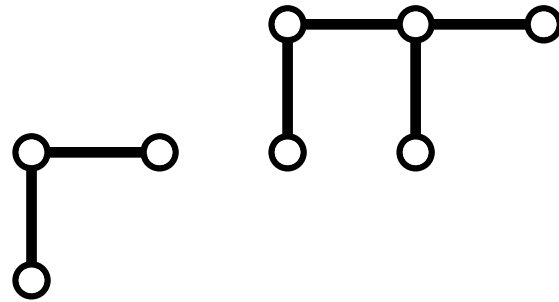

HV-Drawings – Right-Heavy HV-Layout

Right-heavy approach

- Always apply horizontal combination
- Place the larger subtree to the right ← *This can change the embedding!*
Size of subtree := number of vertices

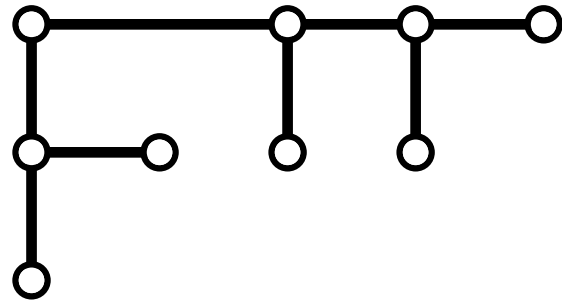

HV-Drawings – Right-Heavy HV-Layout

Right-heavy approach

- Always apply horizontal combination
- Place the larger subtree to the right
Size of subtree := number of vertices

← *This can change the embedding!*

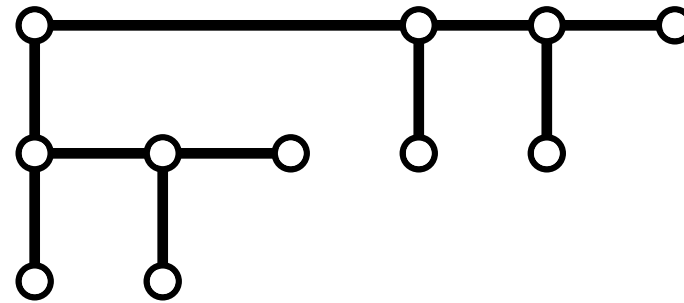
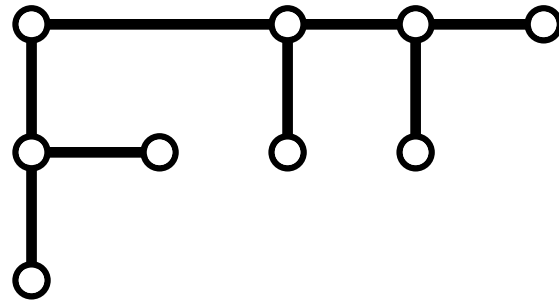

HV-Drawings – Right-Heavy HV-Layout

Right-heavy approach

- Always apply horizontal combination
- Place the larger subtree to the right ← *This can change the embedding!*
 Size of subtree := number of vertices

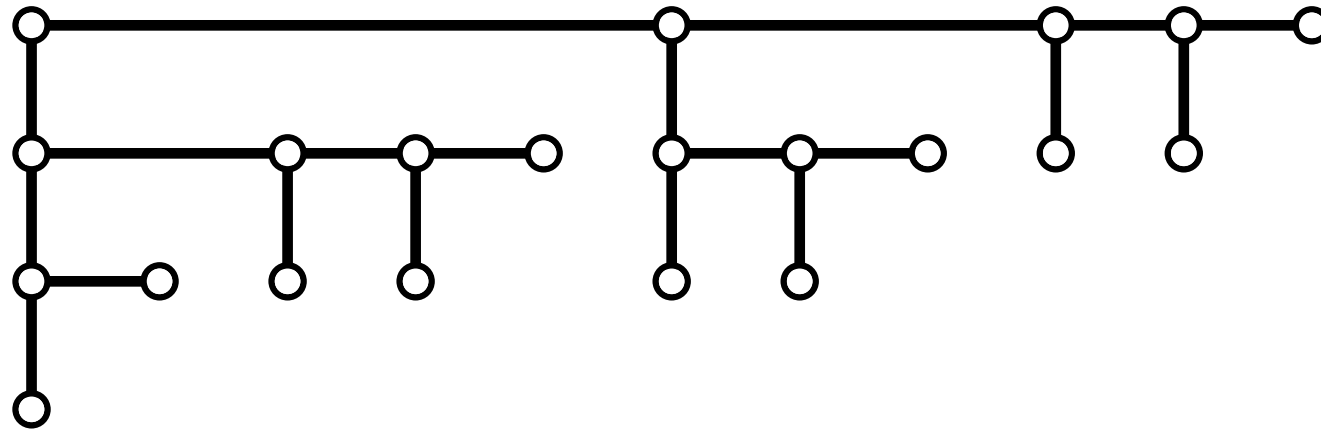

Lemma. Let T be a binary tree. The drawing constructed by the right-heavy approach has

- width at most $2n$ and
- height at most $2 \log n$.

HV-Drawings – Right-Heavy HV-Layout

Right-heavy approach

- Always apply horizontal combination
- Place the larger subtree to the right ← *This can change the embedding!*
 Size of subtree := number of vertices

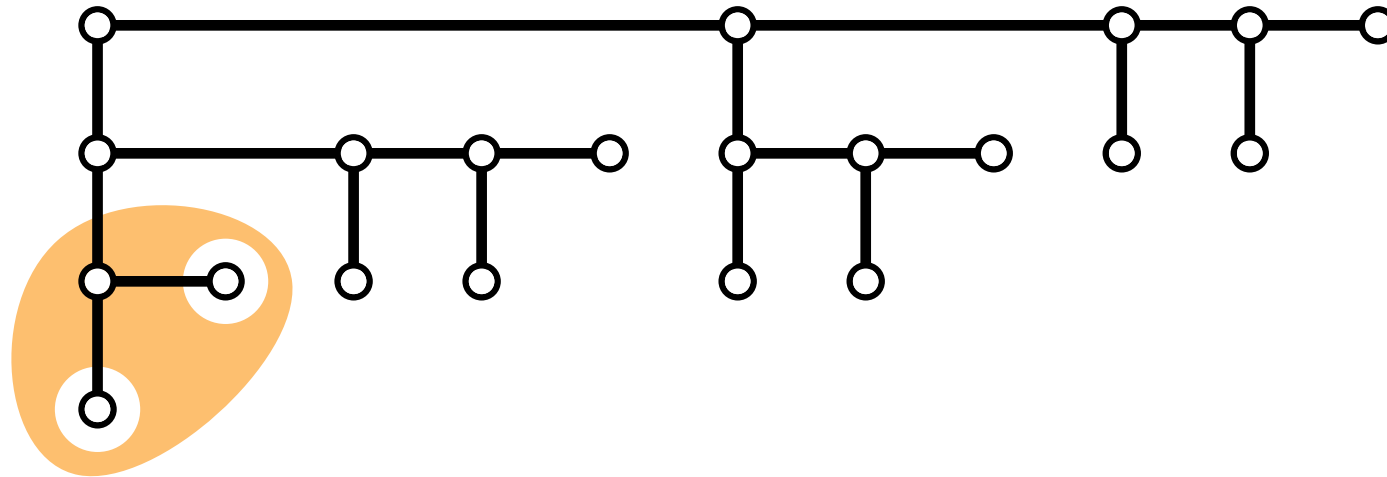

Lemma. Let T be a binary tree. The drawing constructed by the right-heavy approach has

- width at most $n - 1$ and
- height at most

HV-Drawings – Right-Heavy HV-Layout

Right-heavy approach

- Always apply horizontal combination
- Place the larger subtree to the right ← *This can change the embedding!*
 Size of subtree := number of vertices

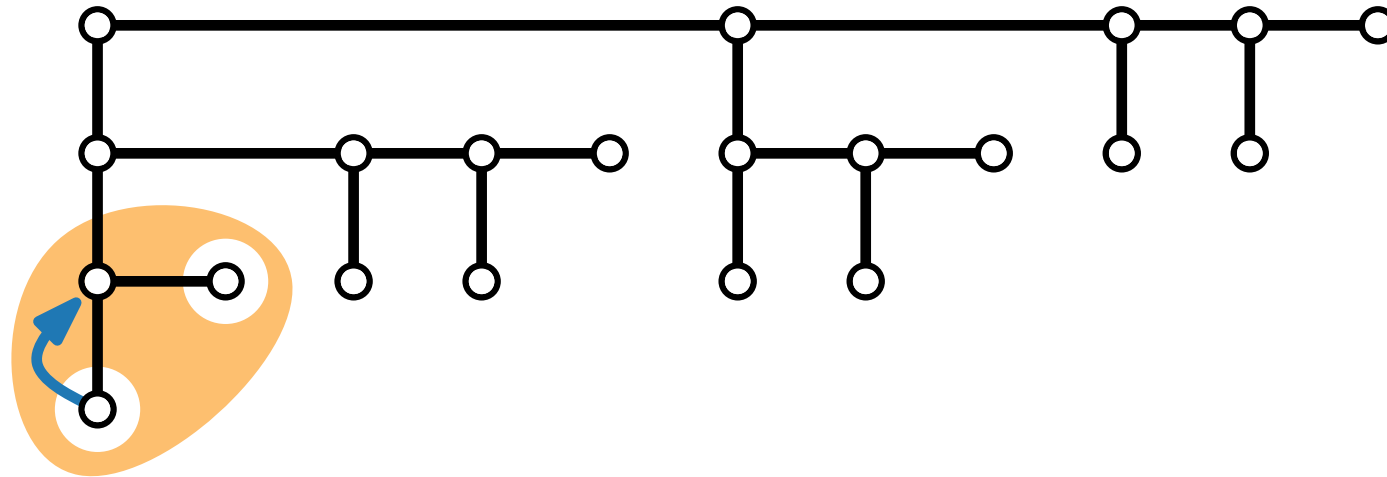

Lemma. Let T be a binary tree. The drawing constructed by the right-heavy approach has

- width at most $n - 1$ and
- height at most

HV-Drawings – Right-Heavy HV-Layout

Right-heavy approach

- Always apply horizontal combination
- Place the larger subtree to the right ← *This can change the embedding!*
 Size of subtree := number of vertices

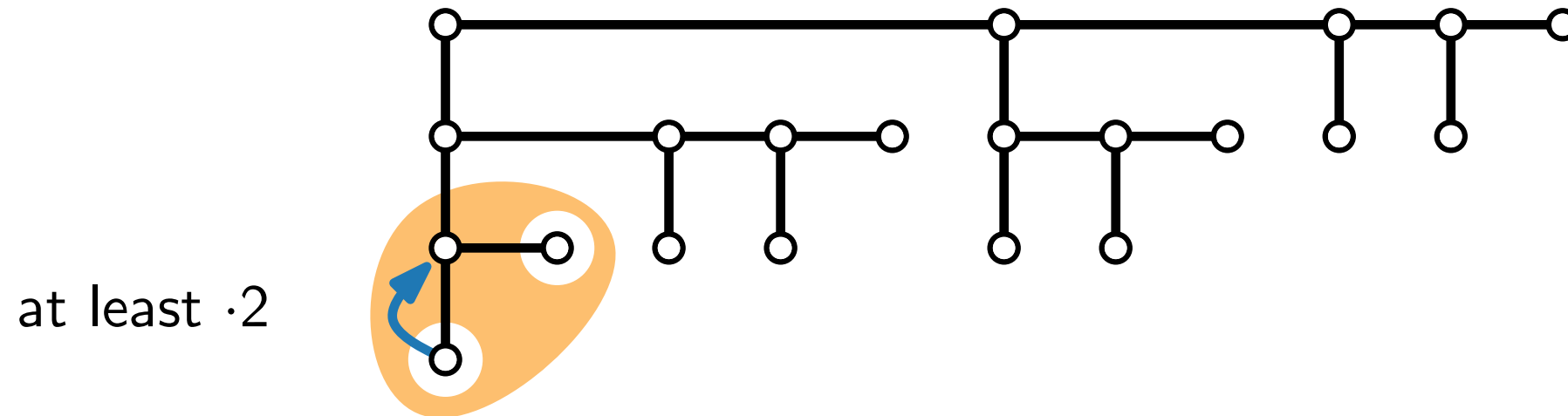

Lemma. Let T be a binary tree. The drawing constructed by the right-heavy approach has

- width at most $n - 1$ and
- height at most

HV-Drawings – Right-Heavy HV-Layout

Right-heavy approach

- Always apply horizontal combination
- Place the larger subtree to the right ← *This can change the embedding!*
 Size of subtree := number of vertices

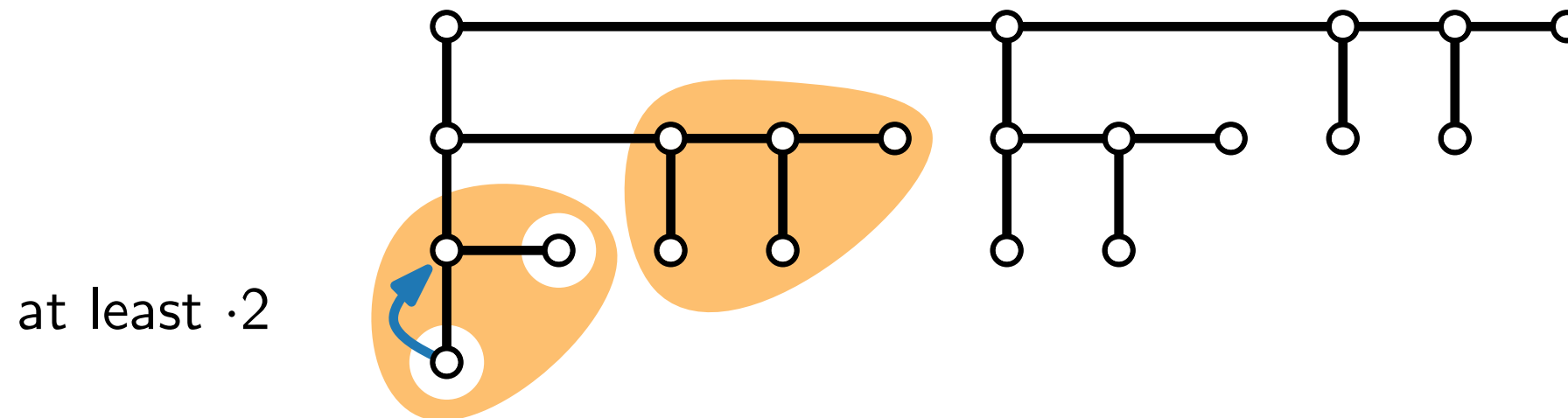

Lemma. Let T be a binary tree. The drawing constructed by the right-heavy approach has

- width at most $n - 1$ and
- height at most

HV-Drawings – Right-Heavy HV-Layout

Right-heavy approach

- Always apply horizontal combination
- Place the larger subtree to the right ← *This can change the embedding!*
 Size of subtree := number of vertices

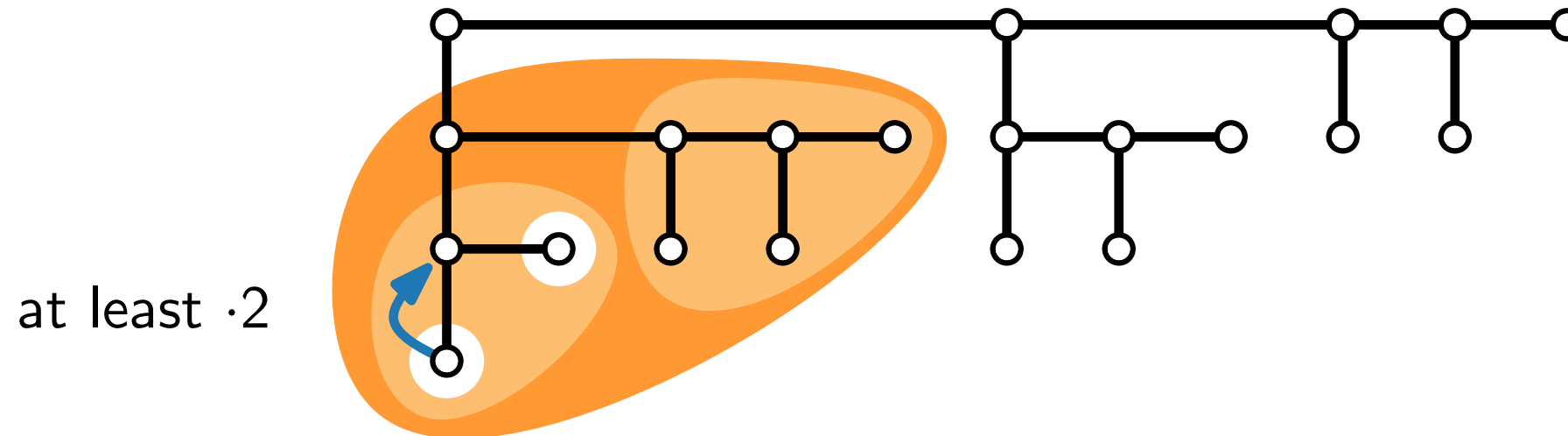

Lemma. Let T be a binary tree. The drawing constructed by the right-heavy approach has

- width at most $n - 1$ and
- height at most

HV-Drawings – Right-Heavy HV-Layout

Right-heavy approach

- Always apply horizontal combination
- Place the larger subtree to the right ← *This can change the embedding!*
 Size of subtree := number of vertices

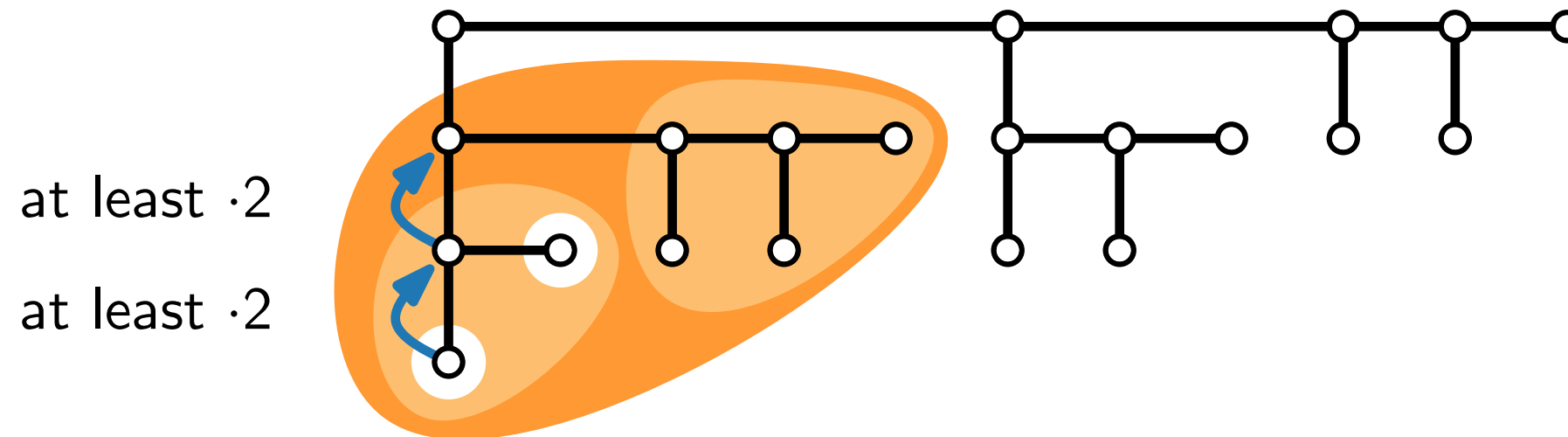

Lemma. Let T be a binary tree. The drawing constructed by the right-heavy approach has

- width at most $n - 1$ and
- height at most

HV-Drawings – Right-Heavy HV-Layout

Right-heavy approach

- Always apply horizontal combination
- Place the larger subtree to the right ← *This can change the embedding!*
 Size of subtree := number of vertices

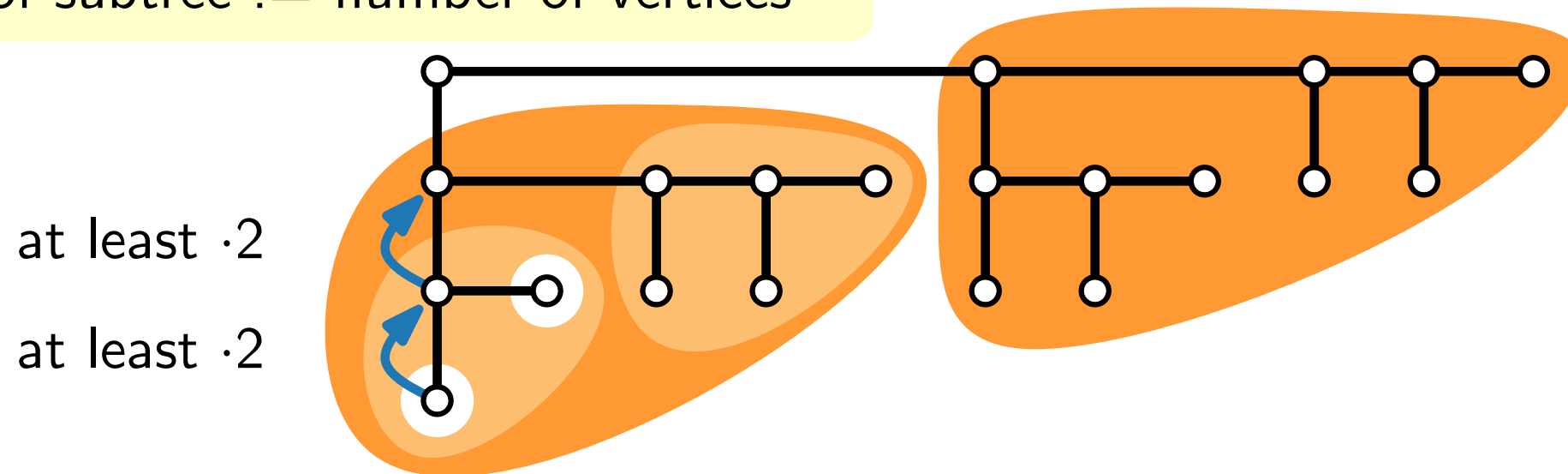

Lemma. Let T be a binary tree. The drawing constructed by the right-heavy approach has

- width at most $n - 1$ and
- height at most

HV-Drawings – Right-Heavy HV-Layout

Right-heavy approach

- Always apply horizontal combination
- Place the larger subtree to the right ← *This can change the embedding!*
 Size of subtree := number of vertices

at least $\cdot 2$

at least $\cdot 2$

at least $\cdot 2$

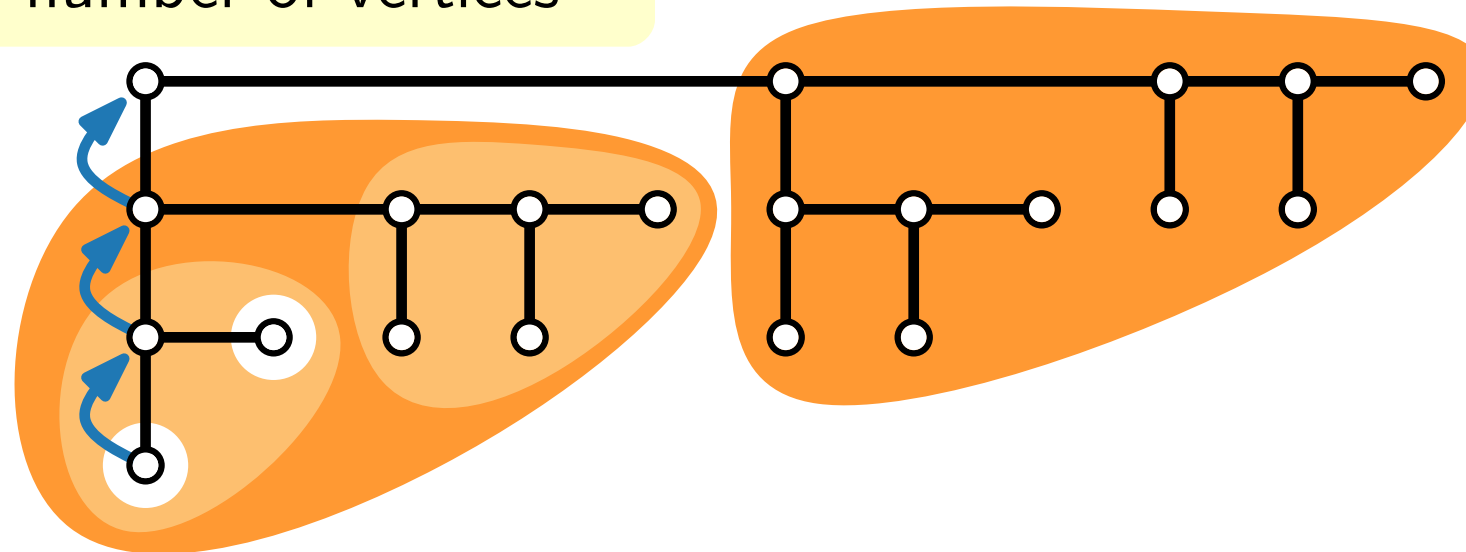

Lemma. Let T be a binary tree. The drawing constructed by the right-heavy approach has

- width at most $n - 1$ and
- height at most

HV-Drawings – Right-Heavy HV-Layout

Right-heavy approach

- Always apply horizontal combination
- Place the larger subtree to the right ← *This can change the embedding!*
 Size of subtree := number of vertices

at least $\cdot 2$

at least $\cdot 2$

at least $\cdot 2$

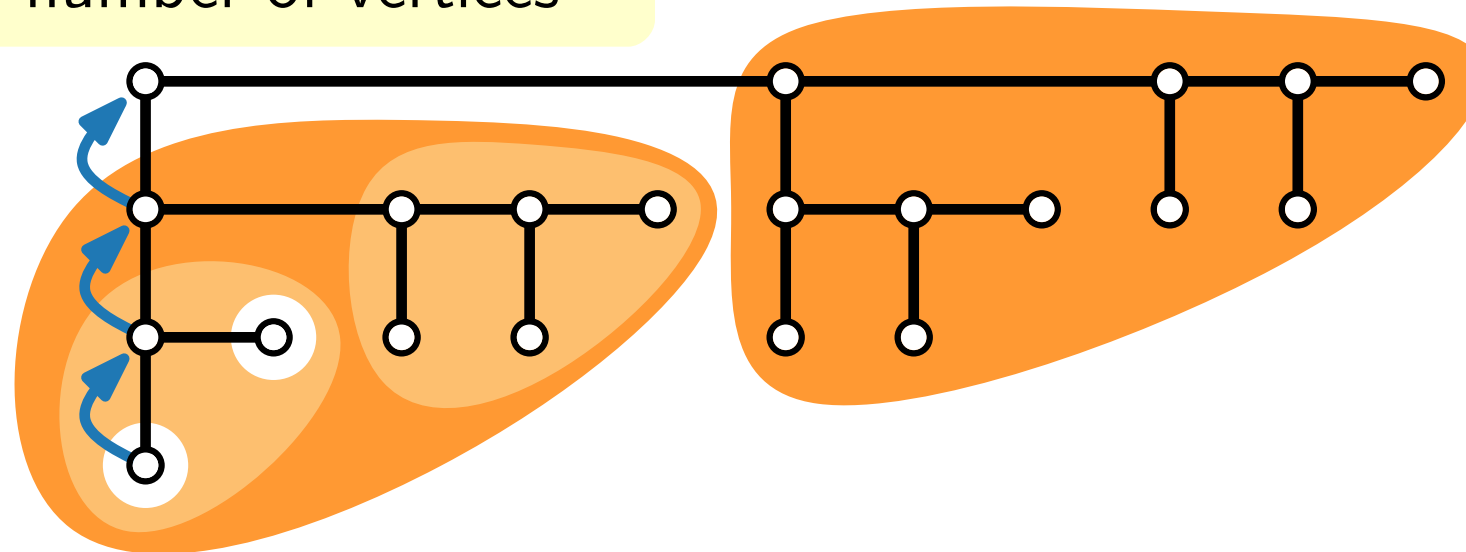

Lemma. Let T be a binary tree. The drawing constructed by the right-heavy approach has

- width at most $n - 1$ and
- height at most $\log_2 n$.

HV-Drawings – Right-Heavy HV-Layout

Right-heavy approach

- Always apply horizontal combination
- Place the larger subtree to the right
Size of subtree := number of vertices

← *This can change the embedding!*

at least $\cdot 2$

at least $\cdot 2$

at least $\cdot 2$

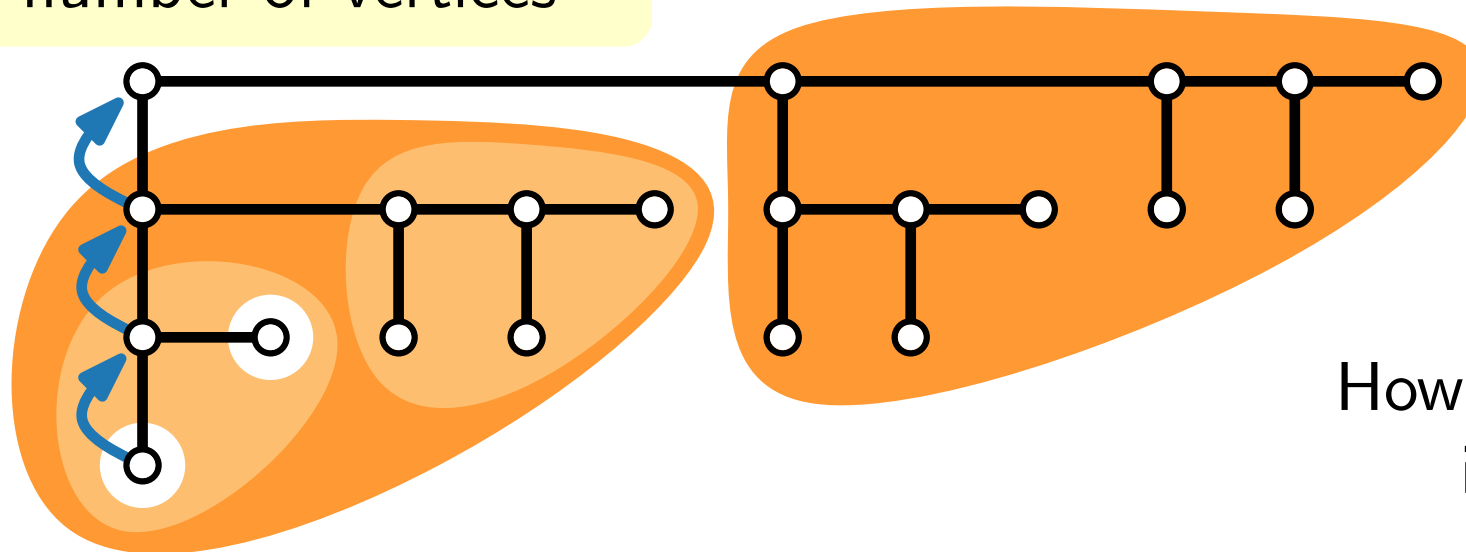

How to implement this
in **linear time**?

Lemma. Let T be a binary tree. The drawing constructed by the right-heavy approach has

- width at most $n - 1$ and
- height at most $\log_2 n$.

HV-Drawings – Result

Theorem.

Let T be a binary tree with n vertices. The right-heavy algorithm constructs in $O(n)$ time a drawing Γ of T s.t.:

HV-Drawings – Result

Theorem.

Let T be a binary tree with n vertices. The right-heavy algorithm constructs in $O(n)$ time a drawing Γ of T s.t.:

- Γ is an HV-drawing
(planar, orthogonal, strictly right-/downward)

HV-Drawings – Result

Theorem.

Let T be a binary tree with n vertices. The right-heavy algorithm constructs in $O(n)$ time a drawing Γ of T s.t.:

- Γ is an HV-drawing
(planar, orthogonal, strictly right-/downward)
- Width is at most $n - 1$

HV-Drawings – Result

Theorem.

Let T be a binary tree with n vertices. The right-heavy algorithm constructs in $O(n)$ time a drawing Γ of T s.t.:

- Γ is an HV-drawing
(planar, orthogonal, strictly right-/downward)
- Width is at most $n - 1$
- Height is at most $\log_2 n$

HV-Drawings – Result

Theorem.

Let T be a binary tree with n vertices. The right-heavy algorithm constructs in $O(n)$ time a drawing Γ of T s.t.:

- Γ is an HV-drawing
(planar, orthogonal, strictly right-/downward)
- Width is at most $n - 1$
- Height is at most $\log_2 n$
- Area is in $O(n \log n)$

HV-Drawings – Result

Theorem.

Let T be a binary tree with n vertices. The right-heavy algorithm constructs in $O(n)$ time a drawing Γ of T s.t.:

- Γ is an HV-drawing
(planar, orthogonal, strictly right-/downward)
- Width is at most $n - 1$
- Height is at most $\log_2 n$
- Area is in $O(n \log n)$  worst-case optimal [exercise]

HV-Drawings – Result

Theorem.

Let T be a binary tree with n vertices. The right-heavy algorithm constructs in $O(n)$ time a drawing Γ of T s.t.:

- Γ is an HV-drawing
(planar, orthogonal, strictly right-/downward)
- Width is at most $n - 1$
- Height is at most $\log_2 n$
- Area is in $O(n \log n)$ ← worst-case optimal [exercise]
- Simply and axially isomorphic subtrees have congruent drawings up to translation

HV-Drawings – Result

Theorem. ~~binary~~ rooted

Let T be a ~~binary~~ tree with n vertices. The right-heavy algorithm constructs in $O(n)$ time a drawing Γ of T s.t.:

- Γ is an HV-drawing
(planar, orthogonal, strictly right-/downward)
- Width is at most $n - 1$
- Height is at most $\log_2 n$
- Area is in $\mathcal{O}(n \log n)$ ← worst-case optimal [exercise]
- Simply and axially isomorphic subtrees have congruent drawings up to translation

HV-Drawings – Result

Theorem. ~~binary~~ ^{rooted}

Let T be a ~~binary~~ tree with n vertices. The right-heavy algorithm constructs in $O(n)$ time a drawing Γ of T s.t.:

- Γ is an HV-drawing
(planar, orthogonal, strictly right-/downward)
- Width is at most $n - 1$
- Height is at most $\log_2 n$
- Area is in $O(n \log n)$  worst-case optimal [exercise]
- Simply and axially isomorphic subtrees have congruent drawings up to translation

General rooted tree

○

HV-Drawings – Result

Theorem. ~~binary~~ ^{rooted}

Let T be a ~~binary~~ tree with n vertices. The right-heavy algorithm constructs in $O(n)$ time a drawing Γ of T s.t.:

- Γ is an HV-drawing
(planar, orthogonal, strictly right-/downward)
- Width is at most $n - 1$
- Height is at most $\log_2 n$
- Area is in $O(n \log n)$ ← **worst-case optimal [exercise]**
- Simply and axially isomorphic subtrees have congruent drawings up to translation

General rooted tree



HV-Drawings – Result

Theorem. ~~binary~~ ^{rooted}

Let T be a ~~binary~~ tree with n vertices. The right-heavy algorithm constructs in $O(n)$ time a drawing Γ of T s.t.:

- Γ is an HV-drawing
(planar, orthogonal, strictly right-/downward)
- Width is at most $n - 1$
- Height is at most $\log_2 n$
- Area is in $O(n \log n)$ ← **worst-case optimal [exercise]**
- Simply and axially isomorphic subtrees have congruent drawings up to translation

General rooted tree

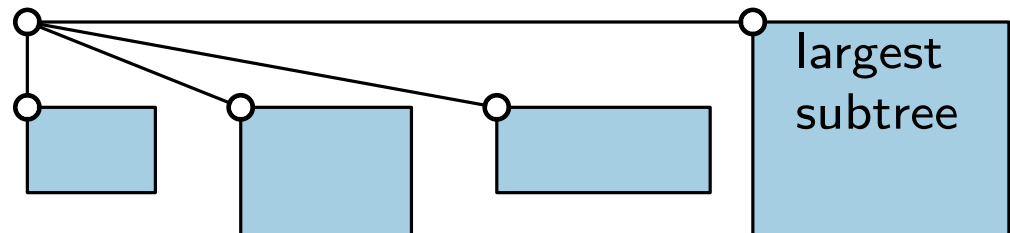

HV-Drawings – Result

Theorem. ~~rooted~~

Let T be a ~~binary~~ tree with n vertices. The right-heavy algorithm constructs in $O(n)$ time a drawing Γ of T s.t.:

- Γ is an HV-drawing
(planar, ~~orthogonal~~, strictly right-/downward)
- Width is at most $n - 1$
- Height is at most $\log_2 n$
- Area is in $O(n \log n)$ ← worst-case optimal [exercise]
- Simply and axially isomorphic subtrees have congruent drawings up to translation

General rooted tree

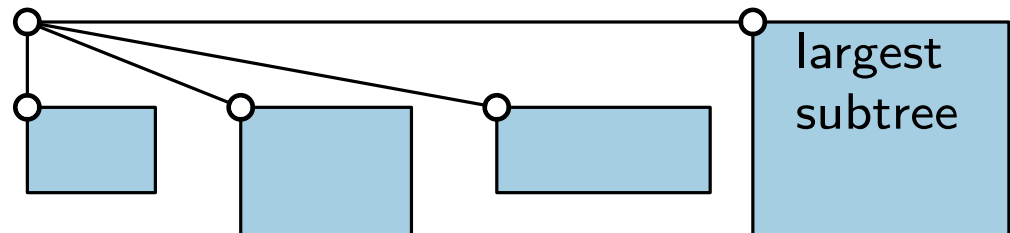

HV-Drawings – Result

Theorem. ~~rooted~~

Let T be a ~~binary~~ tree with n vertices. The right-heavy algorithm constructs in $O(n)$ time a drawing Γ of T s.t.:

- Γ is an HV-drawing
(planar, ~~orthogonal~~, strictly right-/downward)
- Width is at most $n - 1$
- Height is at most $\log_2 n$
- Area is in $O(n \log n)$ ← worst-case optimal [exercise]
- Simply and axially isomorphic subtrees have congruent drawings up to translation

General rooted tree

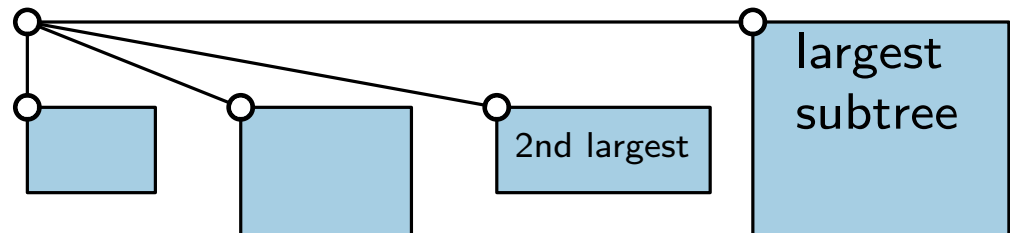

HV-Drawings – Result

Theorem. ~~rooted~~

Let T be a ~~binary~~ tree with n vertices. The right-heavy algorithm constructs in $O(n)$ time a drawing Γ of T s.t.:

- Γ is an HV-drawing
(planar, ~~orthogonal~~, strictly right-/downward)
- Width is at most $n - 1$
- Height is at most $\log_2 n$
- Area is in $O(n \log n)$ ← worst-case optimal [exercise]
- Simply and axially isomorphic subtrees have congruent drawings up to translation

General rooted tree

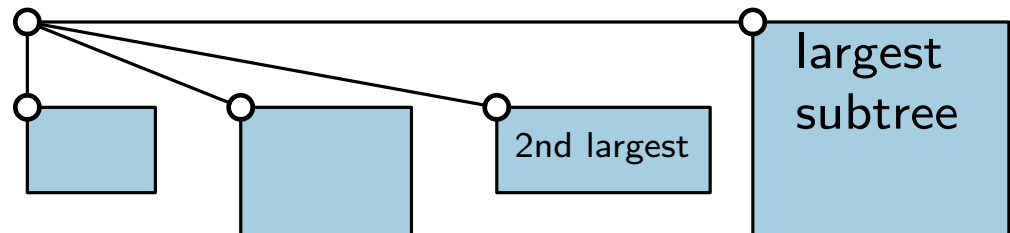

Optimal area?

HV-Drawings – Result

Theorem. ~~rooted~~

Let T be a ~~binary~~ tree with n vertices. The right-heavy algorithm constructs in $O(n)$ time a drawing Γ of T s.t.:

- Γ is an HV-drawing
(planar, ~~orthogonal~~, strictly right-/downward)
- Width is at most $n - 1$
- Height is at most $\log_2 n$
- Area is in $O(n \log n)$ ← **worst-case optimal [exercise]**
- Simply and axially isomorphic subtrees have congruent drawings up to translation

General rooted tree

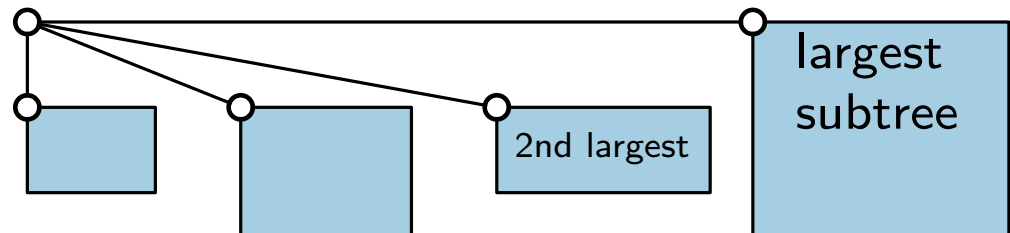

Optimal area?

Not with divide & conquer approach, but can be computed with Dynamic Programming.

Visualization of Graphs

Lecture 1: Drawing Trees

Part III: Radial Layouts

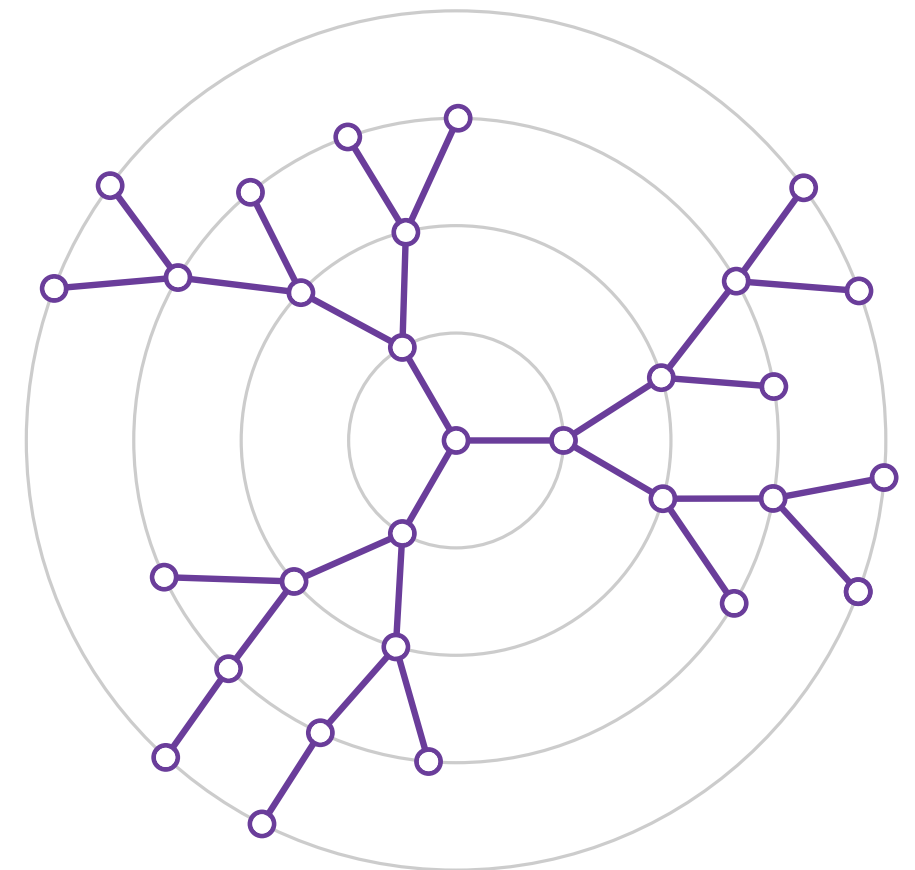
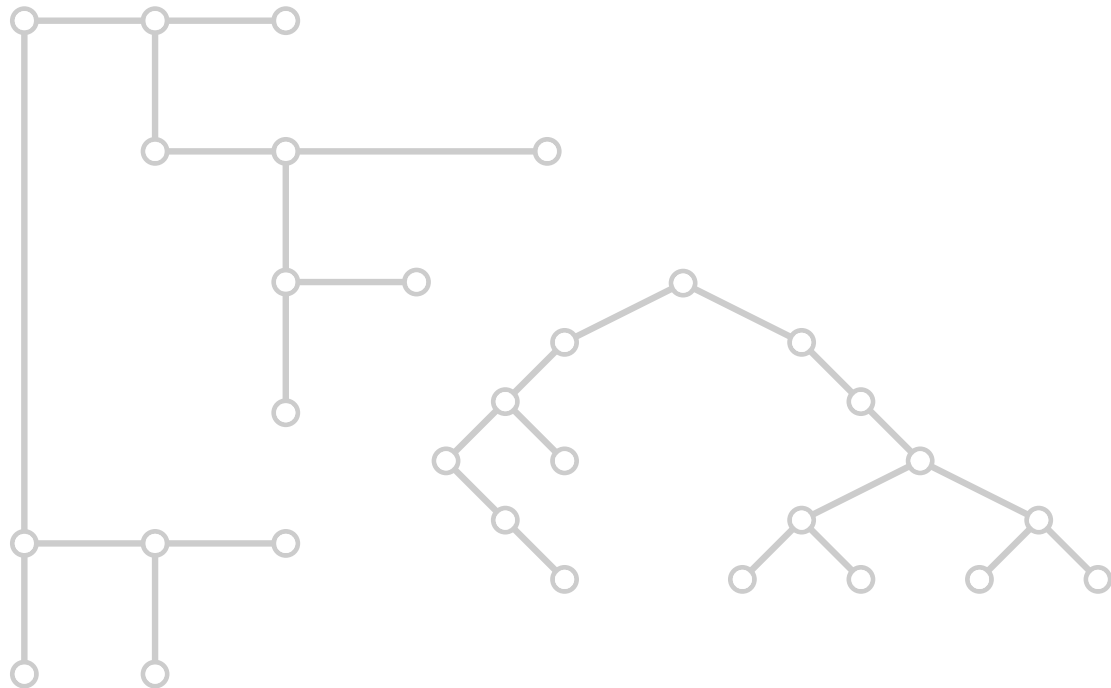

Radial Layouts – Drawing Style

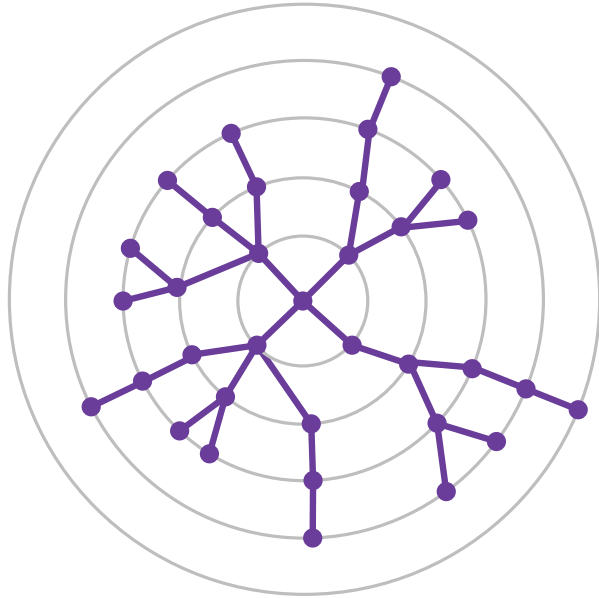

Drawing conventions

Drawing aesthetics to optimize

Radial Layouts – Drawing Style

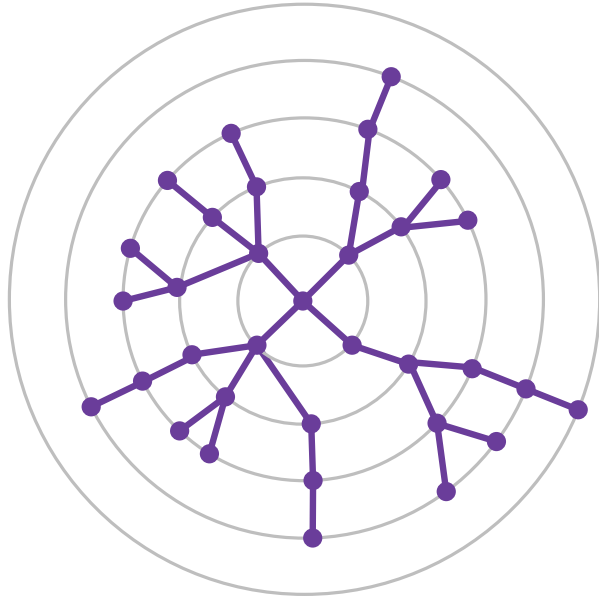

Drawing conventions

- Vertices lie on circular layers according to their depth

Drawing aesthetics to optimize

Radial Layouts – Drawing Style

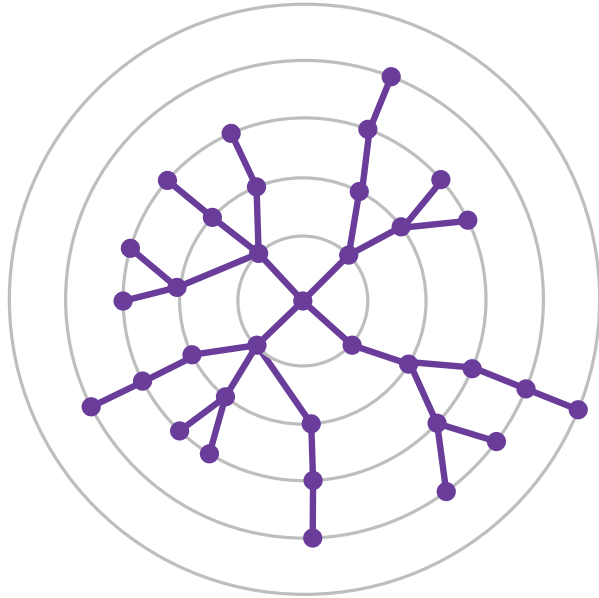

Drawing conventions

- Vertices lie on circular layers according to their depth
- Drawing is planar

Drawing aesthetics to optimize

Radial Layouts – Drawing Style

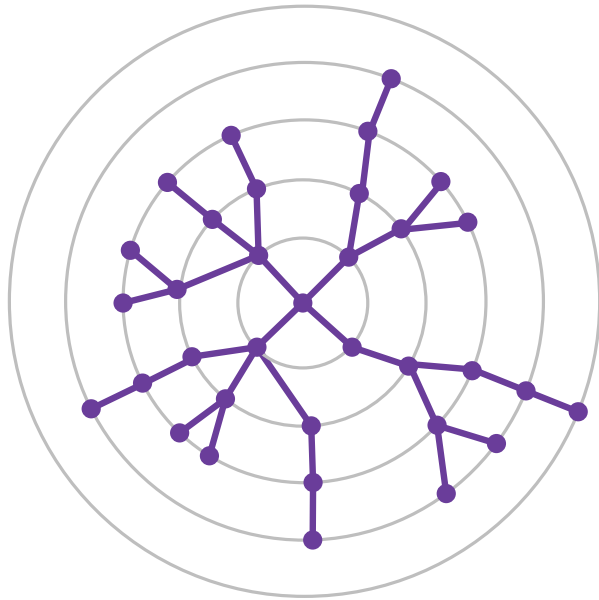

Drawing conventions

- Vertices lie on circular layers according to their depth
- Drawing is planar

Drawing aesthetics to optimize

- Balanced distribution of the vertices

Radial Layouts – Drawing Style

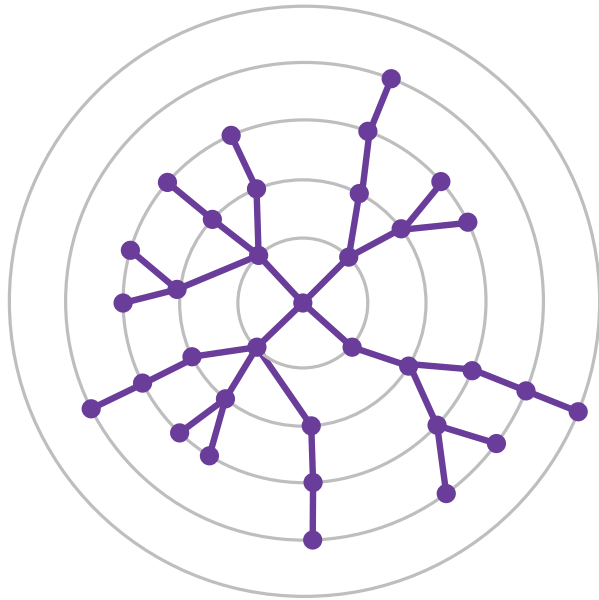

Drawing conventions

- Vertices lie on circular layers according to their depth
- Drawing is planar

Drawing aesthetics to optimize

- Balanced distribution of the vertices

How can an algorithm optimize the distribution of the vertices?

Radial Layouts – Algorithm Attempt

Idea

- Reserve area corresponding to size $\ell(u)$ of $T(u)$:

Radial Layouts – Algorithm Attempt

Idea

- Reserve area corresponding to size $\ell(u)$ of $T(u)$:

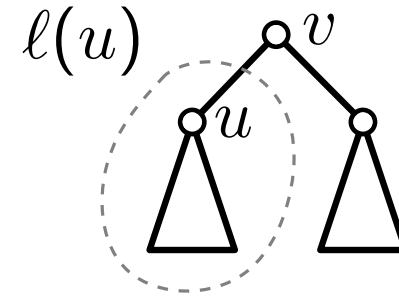

Radial Layouts – Algorithm Attempt

Idea

- Reserve area corresponding to size $\ell(u)$ of $T(u)$:

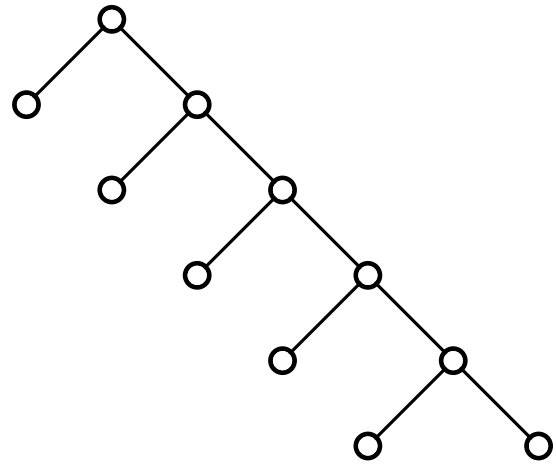
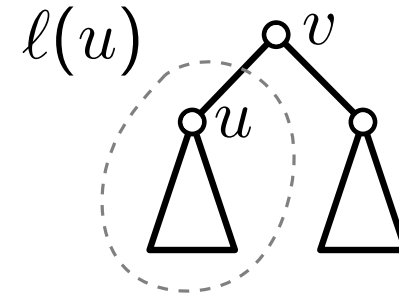

Radial Layouts – Algorithm Attempt

Idea

- Reserve area corresponding to size $\ell(u)$ of $T(u)$:

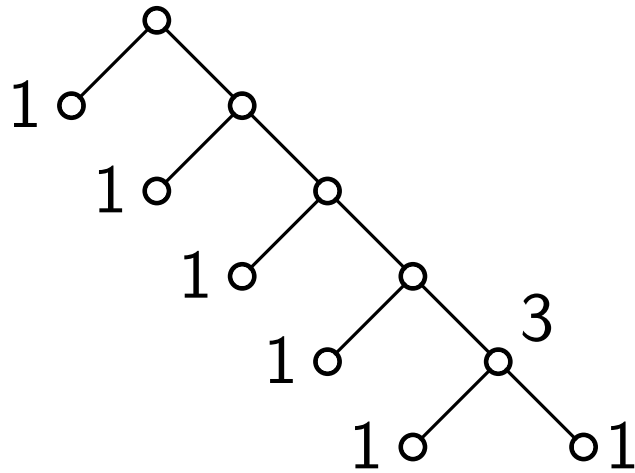
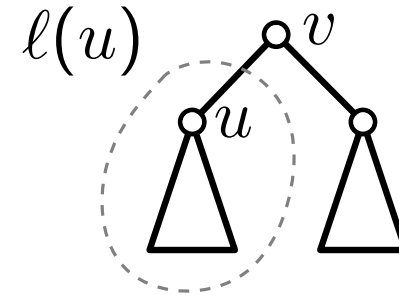

Radial Layouts – Algorithm Attempt

Idea

- Reserve area corresponding to size $\ell(u)$ of $T(u)$:

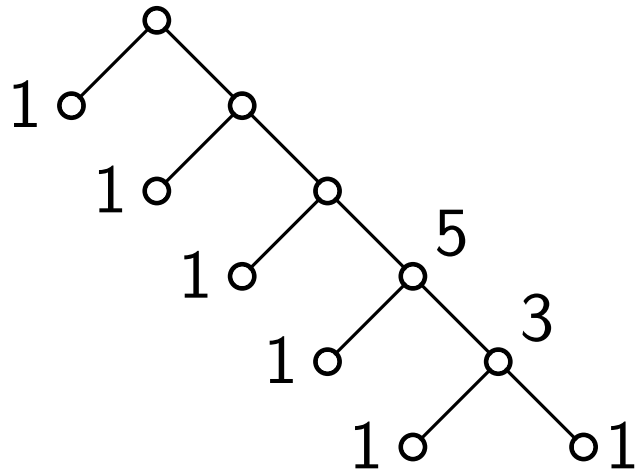
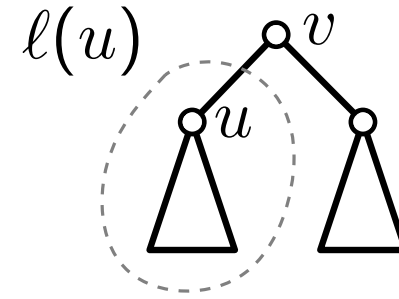

Radial Layouts – Algorithm Attempt

Idea

- Reserve area corresponding to size $\ell(u)$ of $T(u)$:

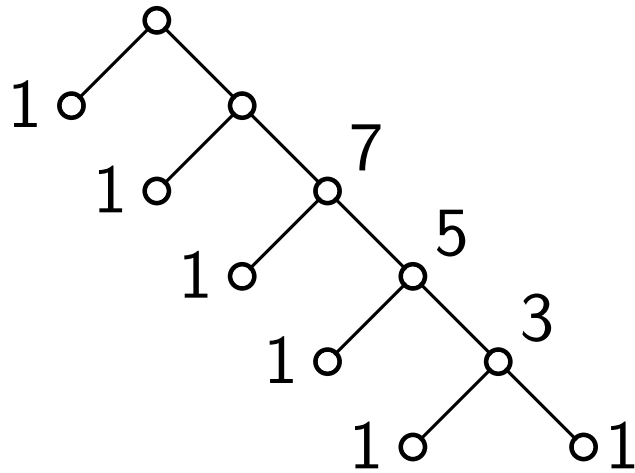
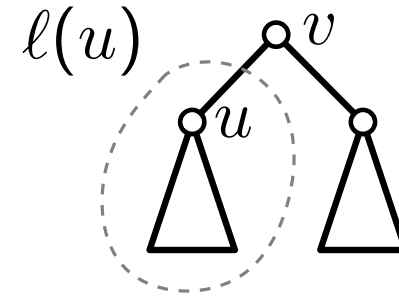

Radial Layouts – Algorithm Attempt

Idea

- Reserve area corresponding to size $\ell(u)$ of $T(u)$:

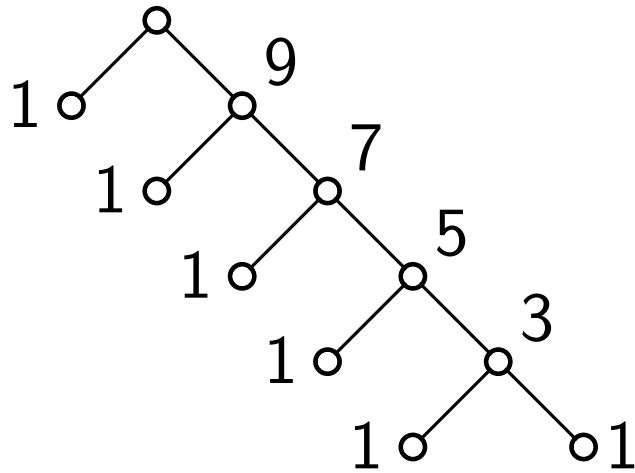
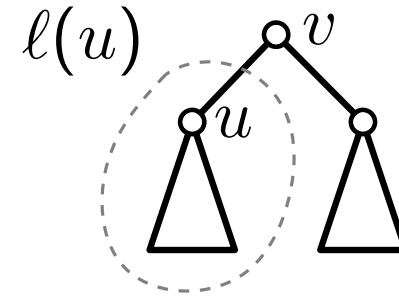

Radial Layouts – Algorithm Attempt

Idea

- Reserve area corresponding to size $\ell(u)$ of $T(u)$:

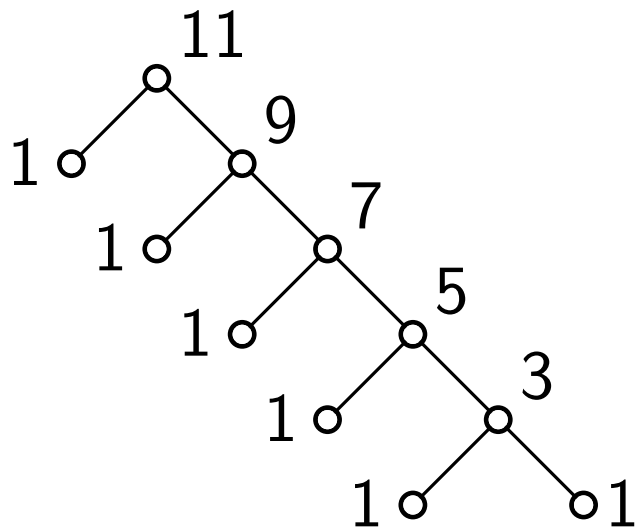
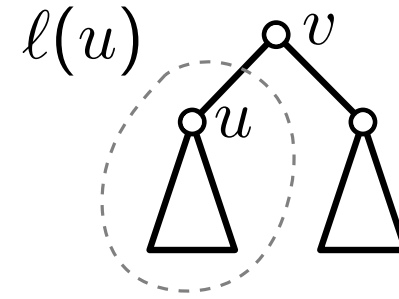

Radial Layouts – Algorithm Attempt

Idea

- Reserve area corresponding to size $\ell(u)$ of $T(u)$:

$$\tau_u = \frac{\ell(u)}{\ell(v) - 1}$$

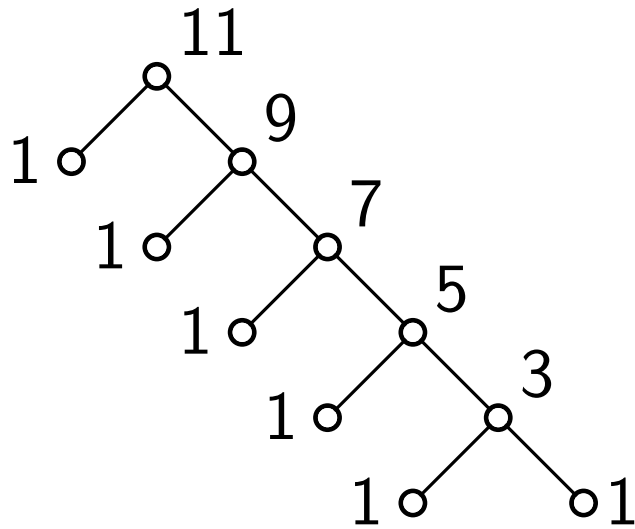
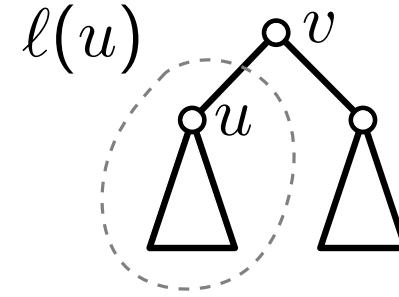

Radial Layouts – Algorithm Attempt

Idea

- Reserve area corresponding to size $\ell(u)$ of $T(u)$:

$$\tau_u = \frac{\ell(u)}{\ell(v) - 1}$$

- Place u in the middle of its area

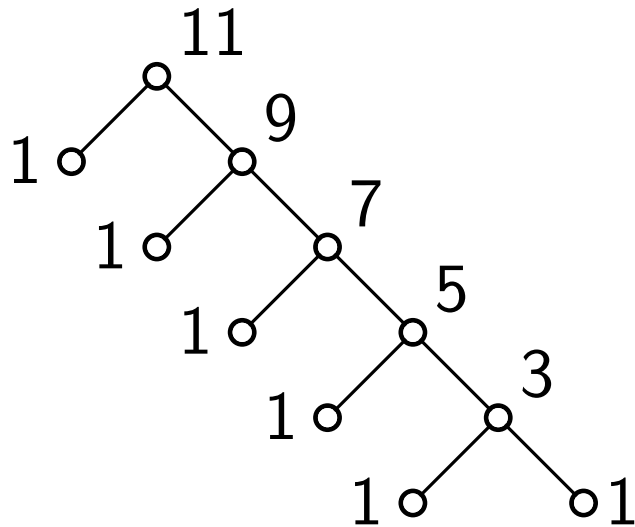
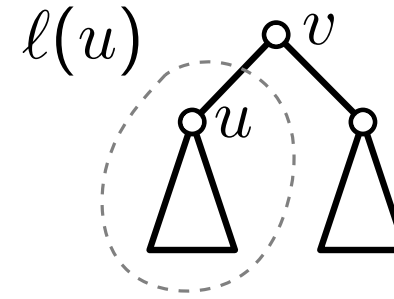

Radial Layouts – Algorithm Attempt

Idea

- Reserve area corresponding to size $\ell(u)$ of $T(u)$:

$$\tau_u = \frac{\ell(u)}{\ell(v) - 1}$$

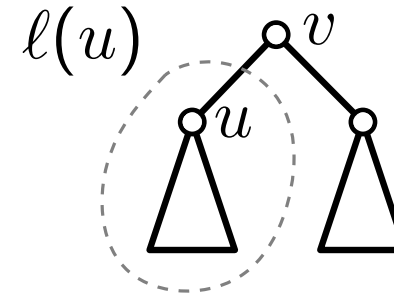

- Place u in the middle of its area

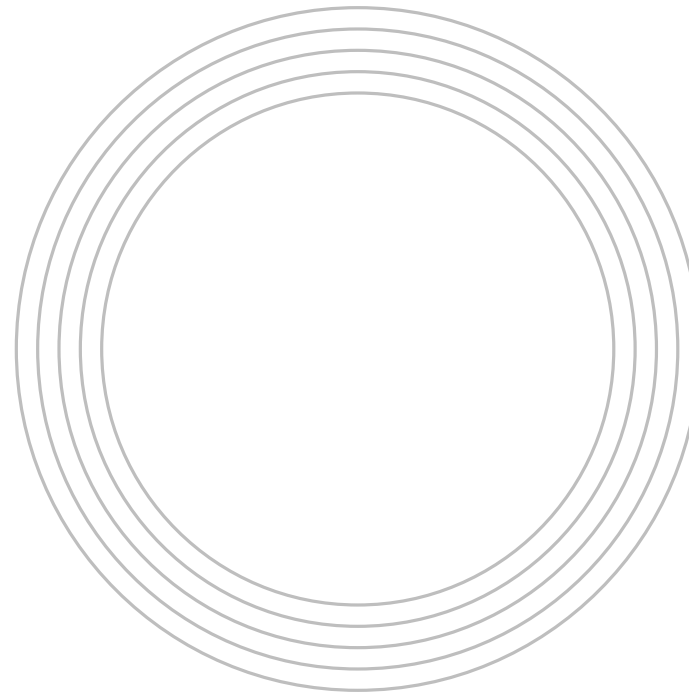
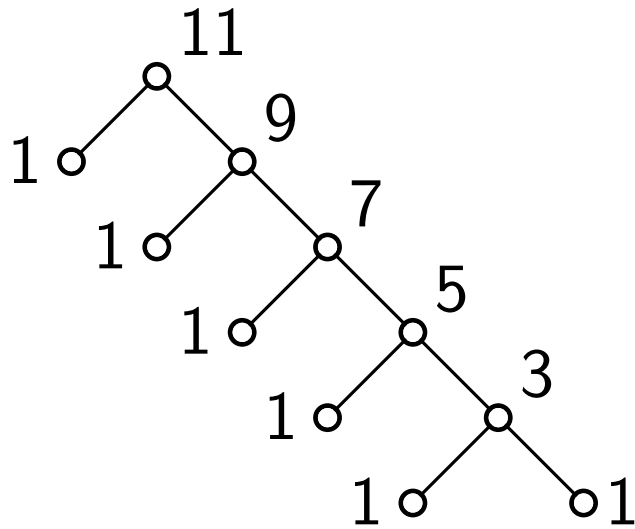

Radial Layouts – Algorithm Attempt

Idea

- Reserve area corresponding to size $\ell(u)$ of $T(u)$:

$$\tau_u = \frac{\ell(u)}{\ell(v) - 1}$$

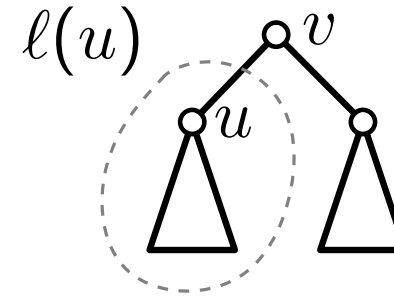

- Place u in the middle of its area

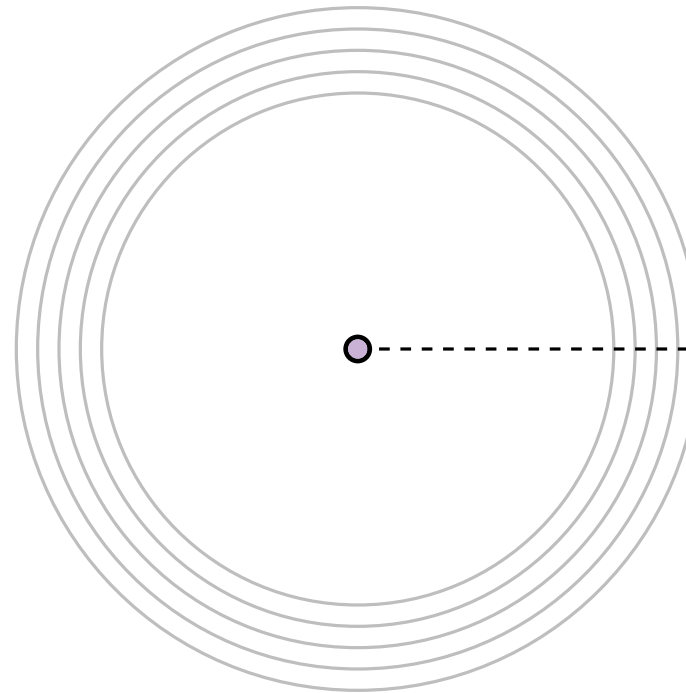
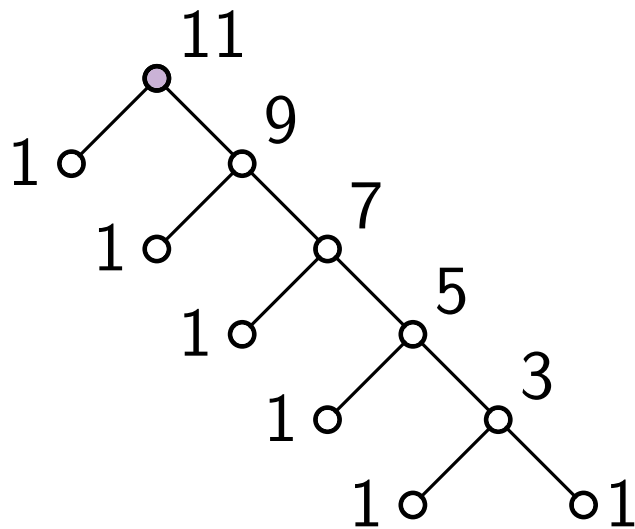

Radial Layouts – Algorithm Attempt

Idea

- Reserve area corresponding to size $\ell(u)$ of $T(u)$:

$$\tau_u = \frac{\ell(u)}{\ell(v) - 1}$$

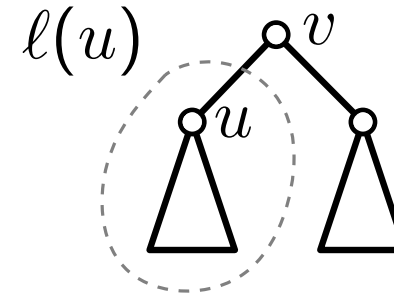

- Place u in the middle of its area

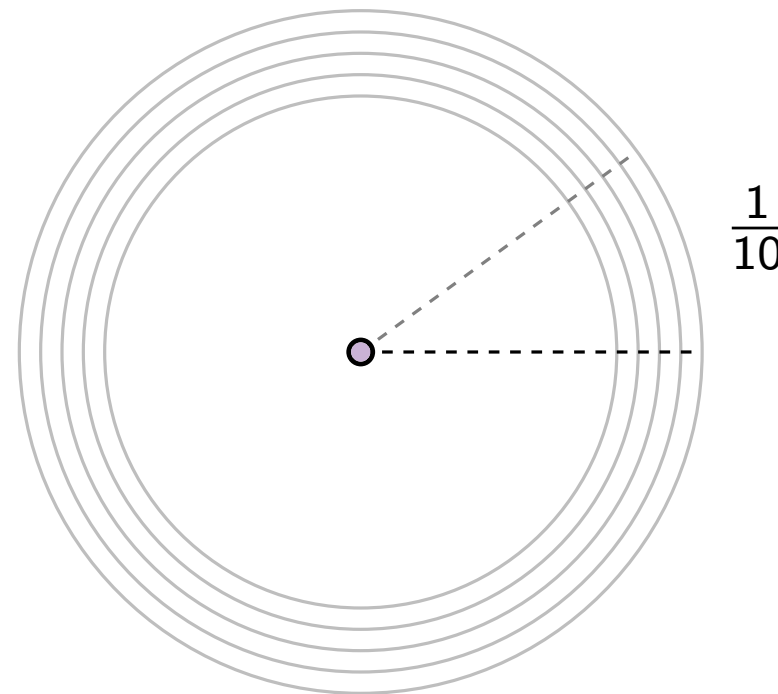
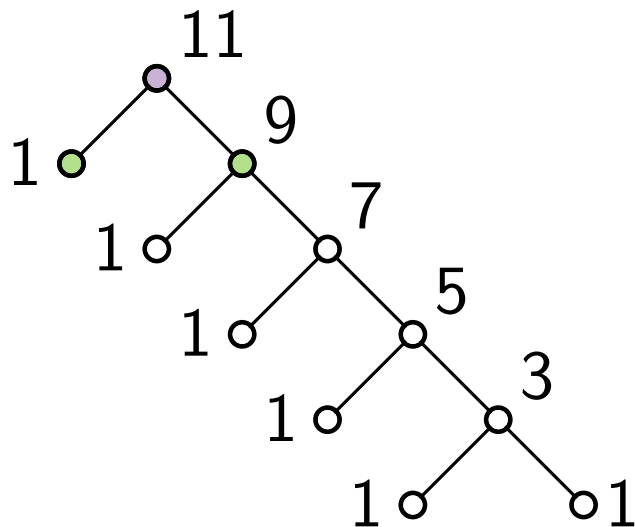

Radial Layouts – Algorithm Attempt

Idea

- Reserve area corresponding to size $\ell(u)$ of $T(u)$:

$$\tau_u = \frac{\ell(u)}{\ell(v) - 1}$$

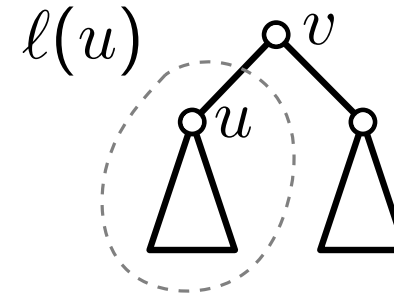

- Place u in the middle of its area

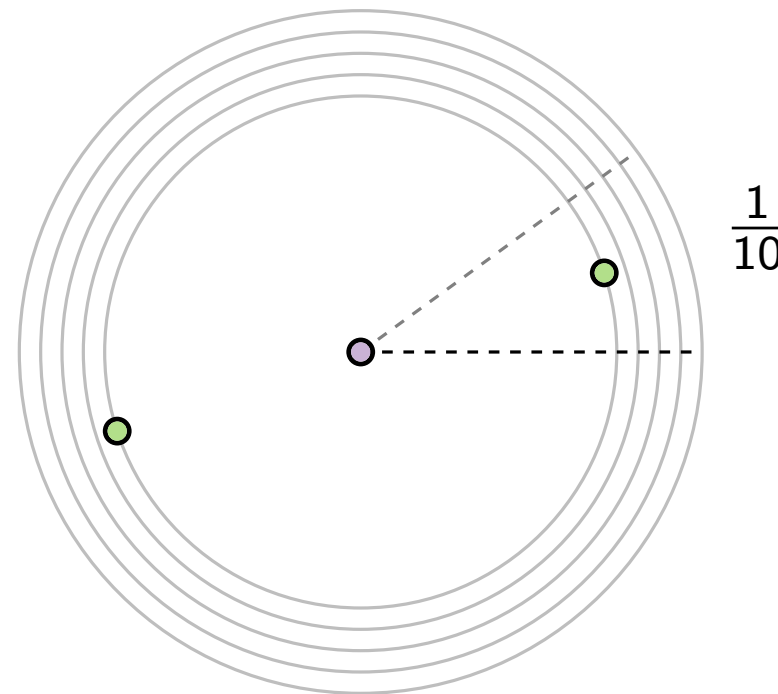
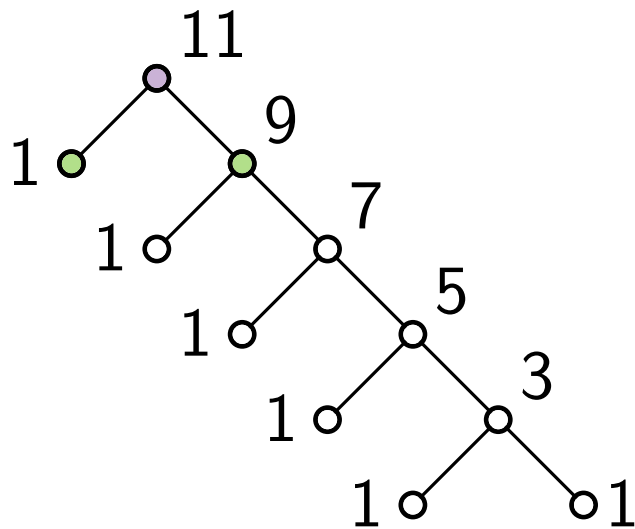

Radial Layouts – Algorithm Attempt

Idea

- Reserve area corresponding to size $\ell(u)$ of $T(u)$:

$$\tau_u = \frac{\ell(u)}{\ell(v) - 1}$$

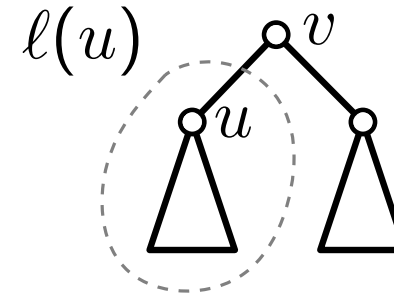

- Place u in the middle of its area

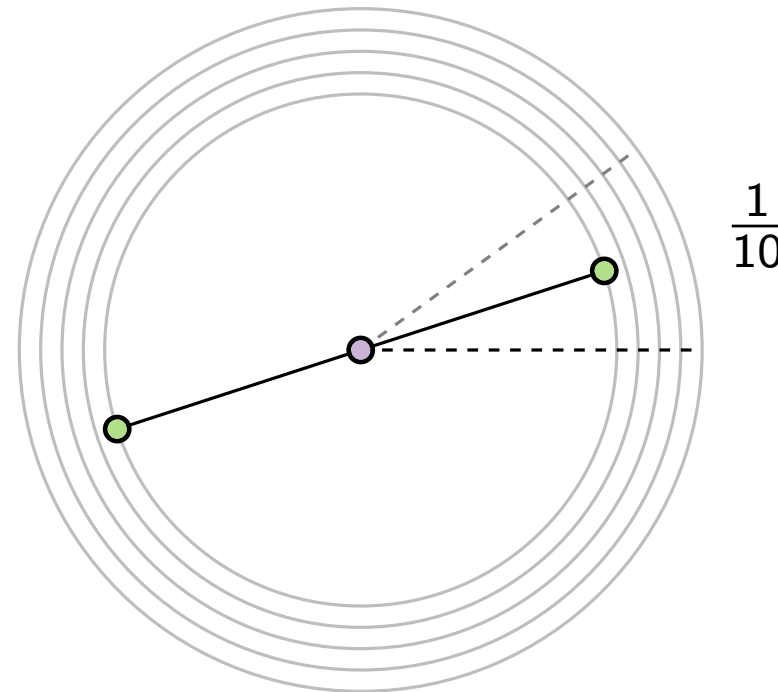
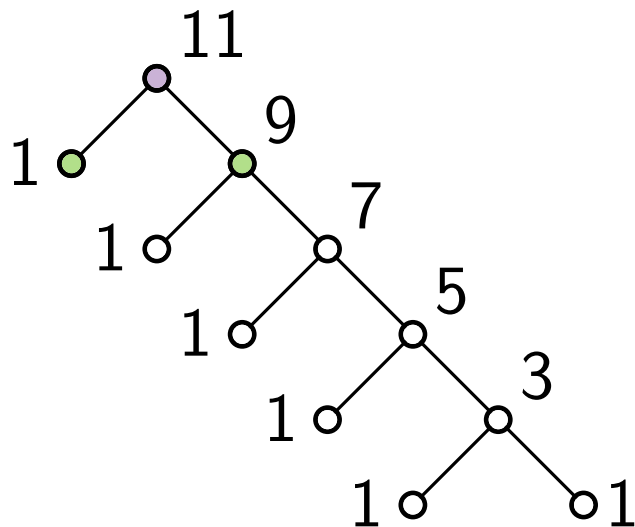

Radial Layouts – Algorithm Attempt

Idea

- Reserve area corresponding to size $\ell(u)$ of $T(u)$:

$$\tau_u = \frac{\ell(u)}{\ell(v) - 1}$$

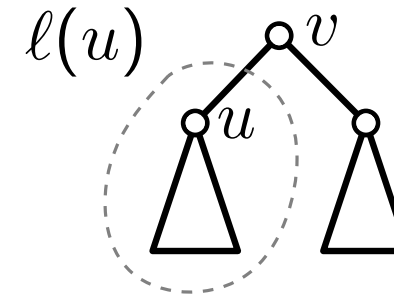

- Place u in the middle of its area

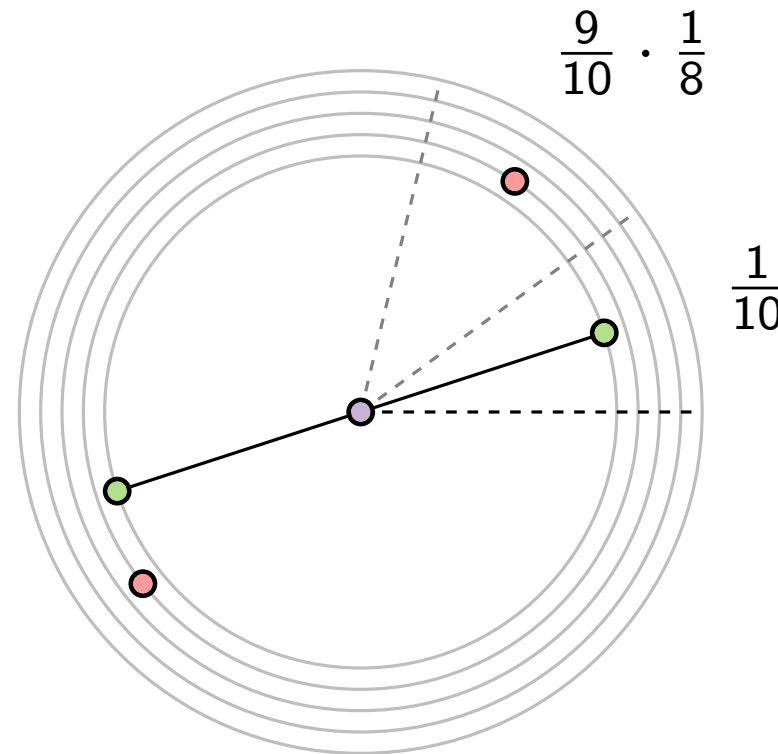
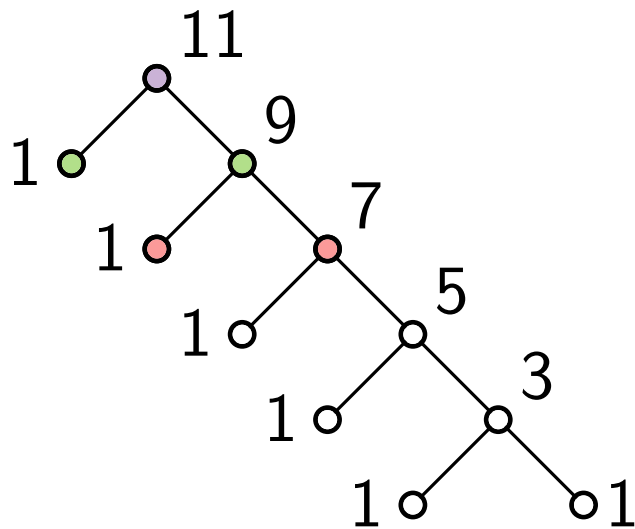

Radial Layouts – Algorithm Attempt

Idea

- Reserve area corresponding to size $\ell(u)$ of $T(u)$:

$$\tau_u = \frac{\ell(u)}{\ell(v) - 1}$$

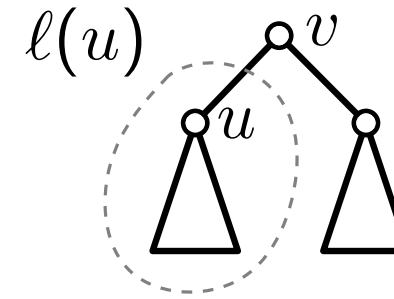

- Place u in the middle of its area

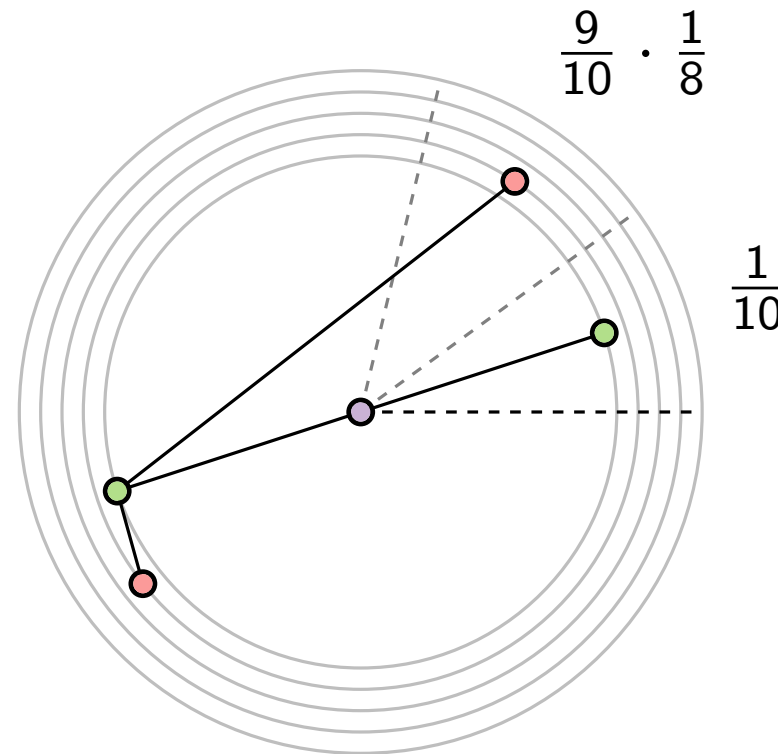
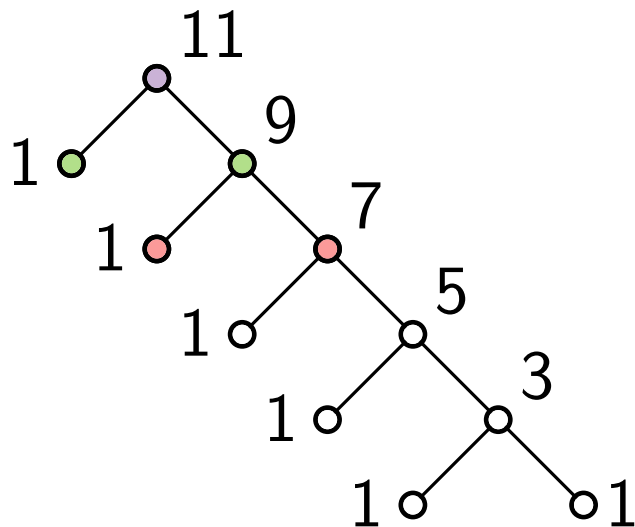

Radial Layouts – Algorithm Attempt

Idea

- Reserve area corresponding to size $\ell(u)$ of $T(u)$:

$$\tau_u = \frac{\ell(u)}{\ell(v) - 1}$$

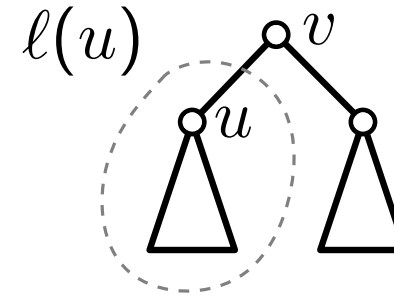

- Place u in the middle of its area

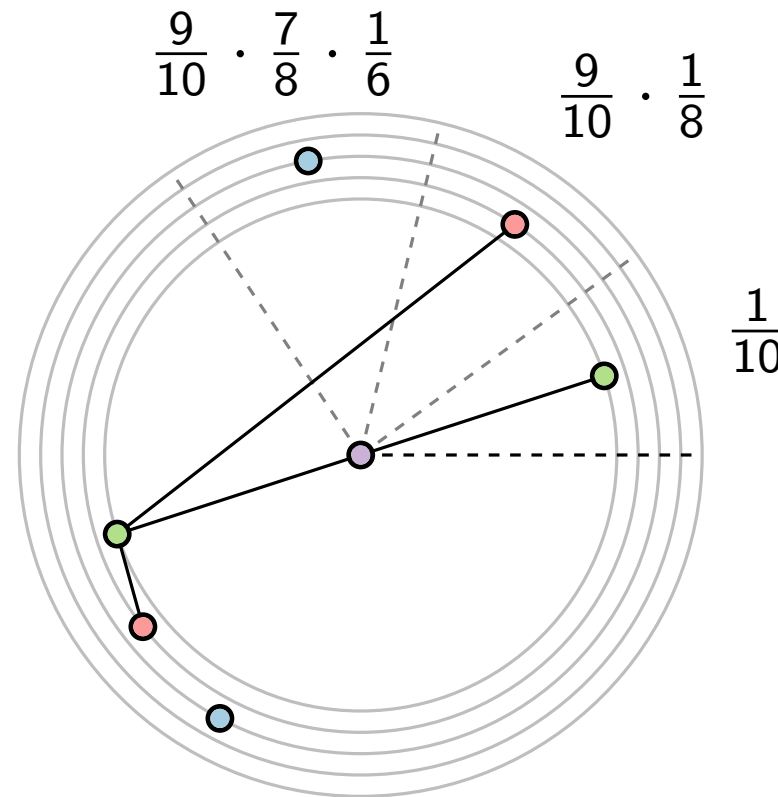
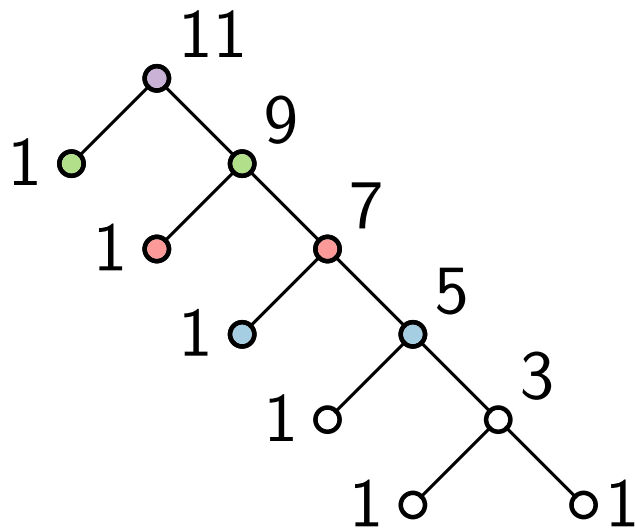

Radial Layouts – Algorithm Attempt

Idea

- Reserve area corresponding to size $\ell(u)$ of $T(u)$:

$$\tau_u = \frac{\ell(u)}{\ell(v) - 1}$$

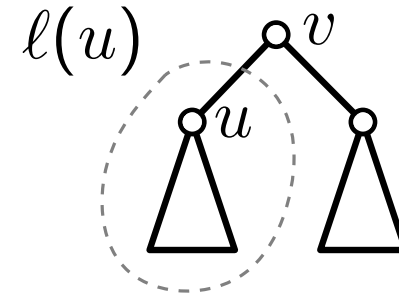

- Place u in the middle of its area

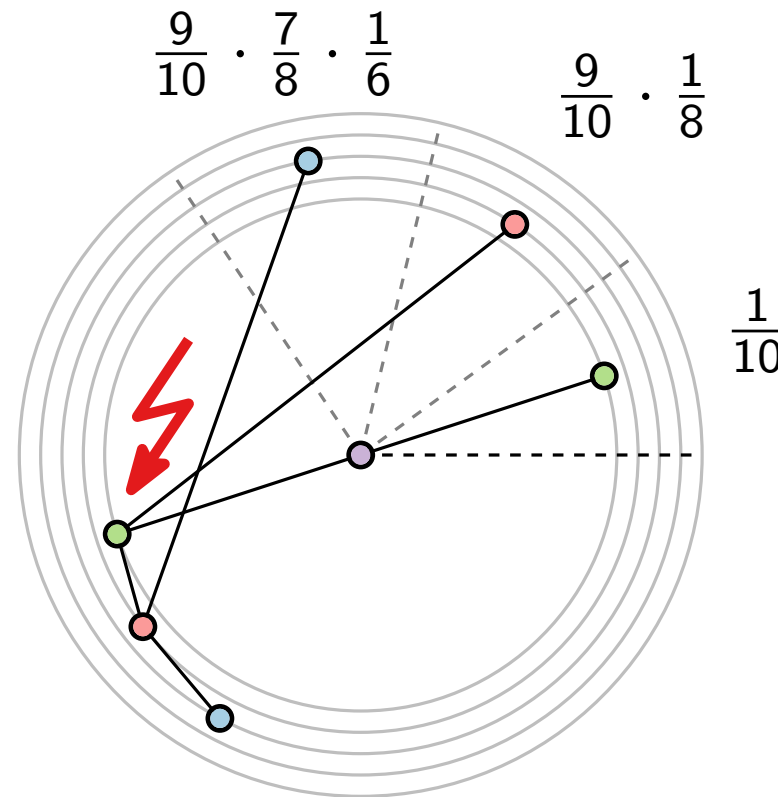
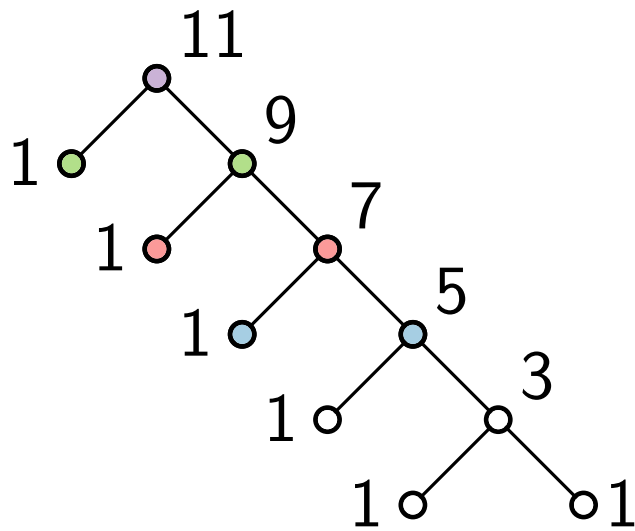

Radial Layouts – How To Avoid Crossings

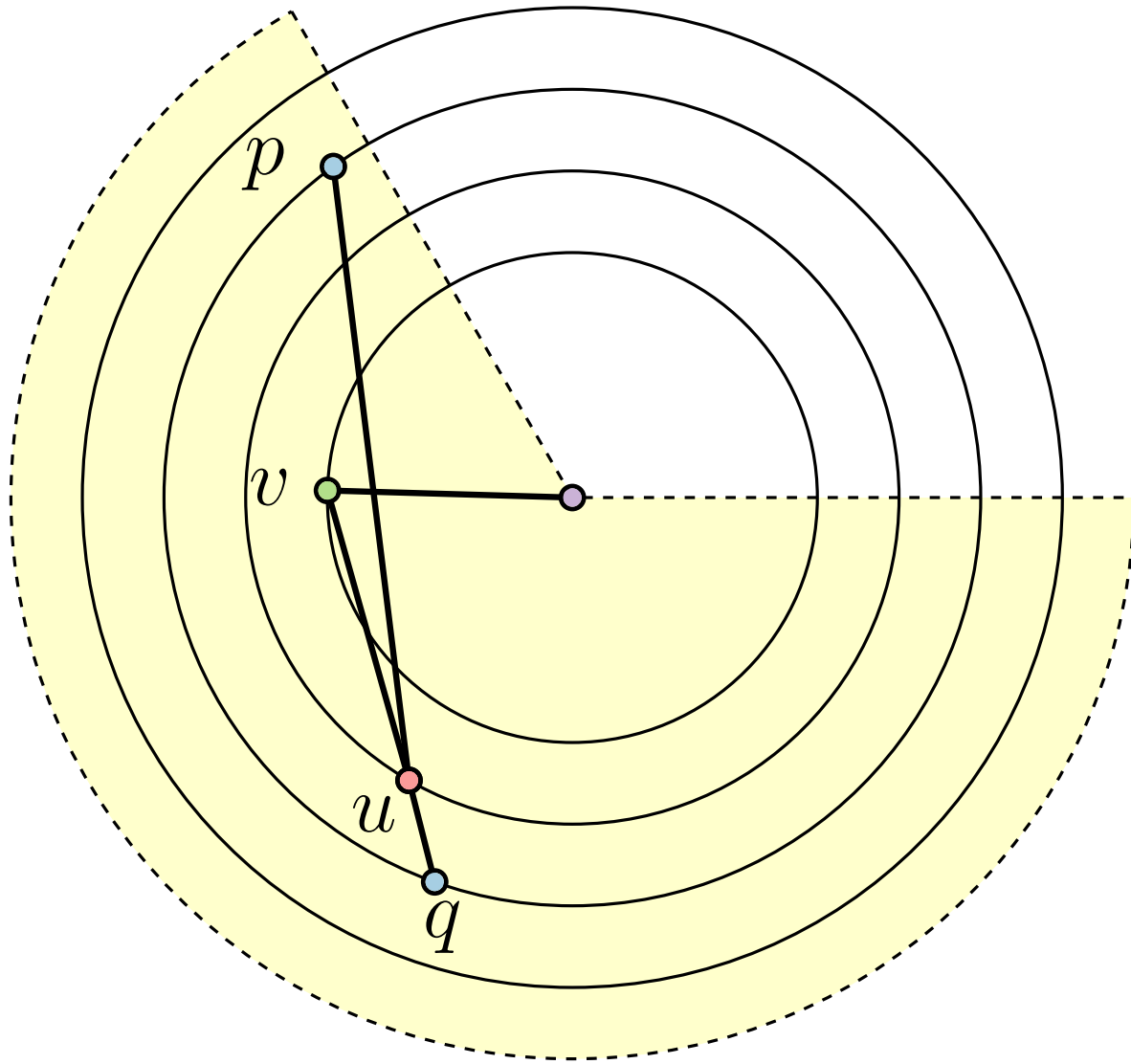

Radial Layouts – How To Avoid Crossings

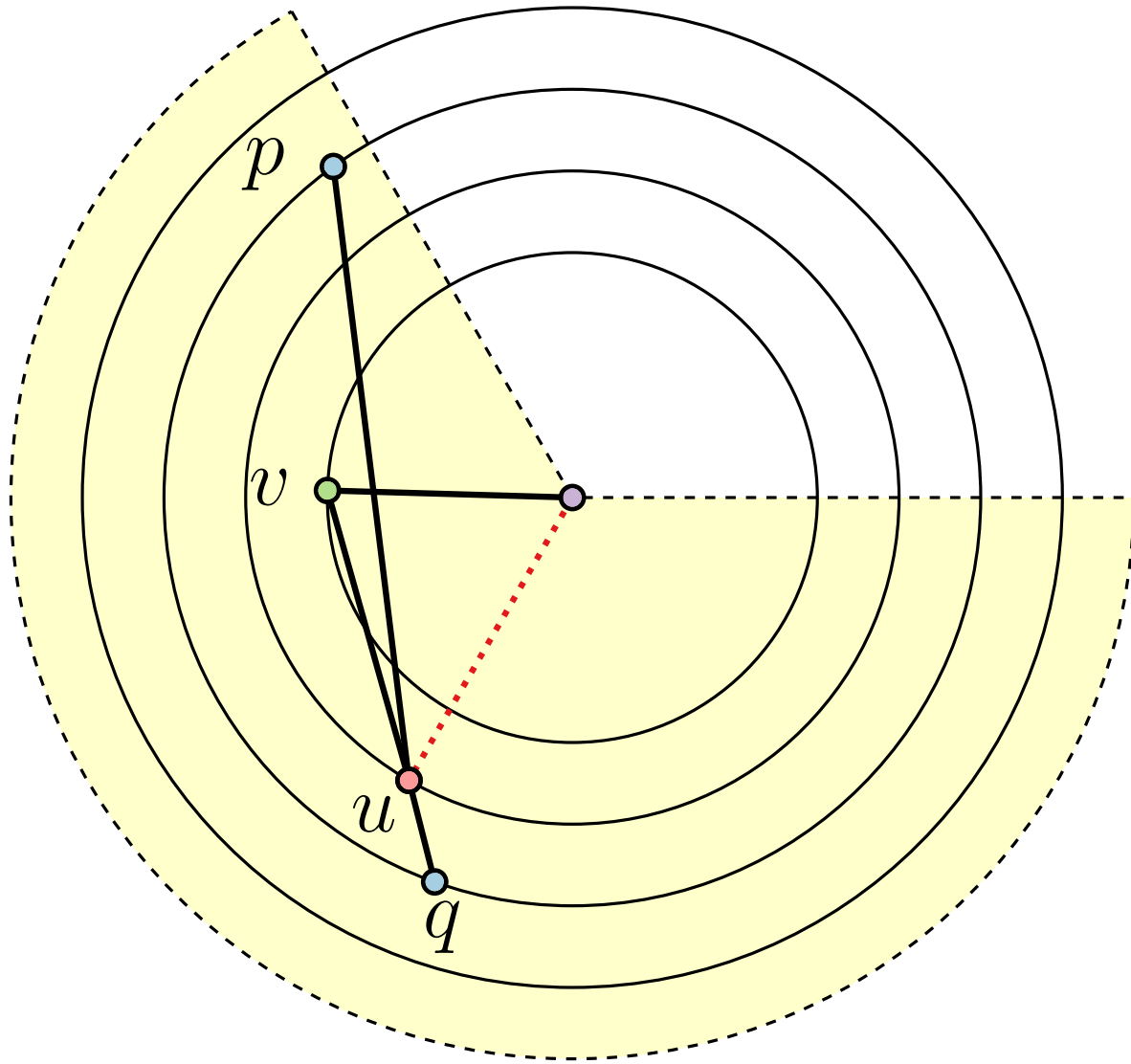

Radial Layouts – How To Avoid Crossings

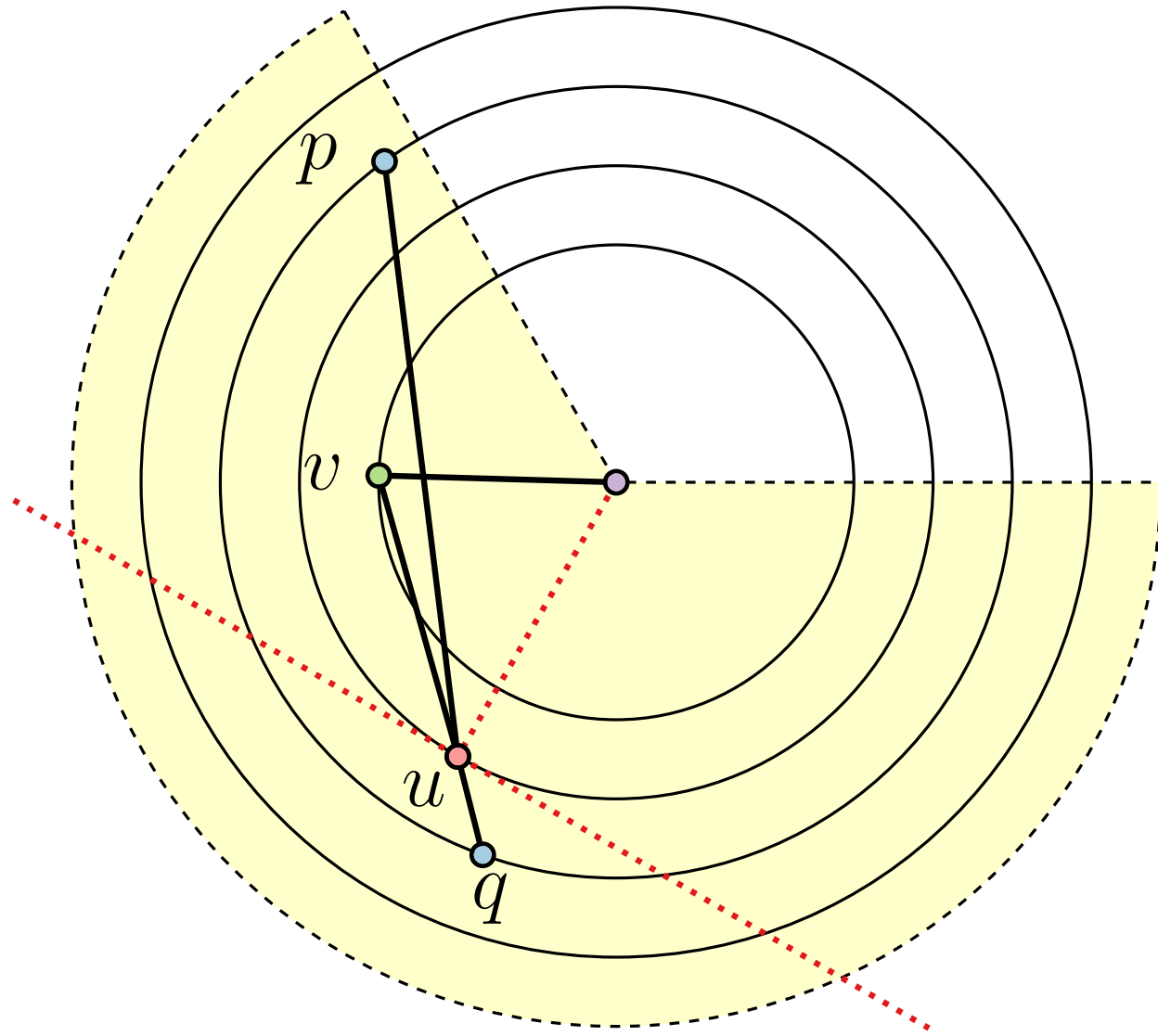

Radial Layouts – How To Avoid Crossings

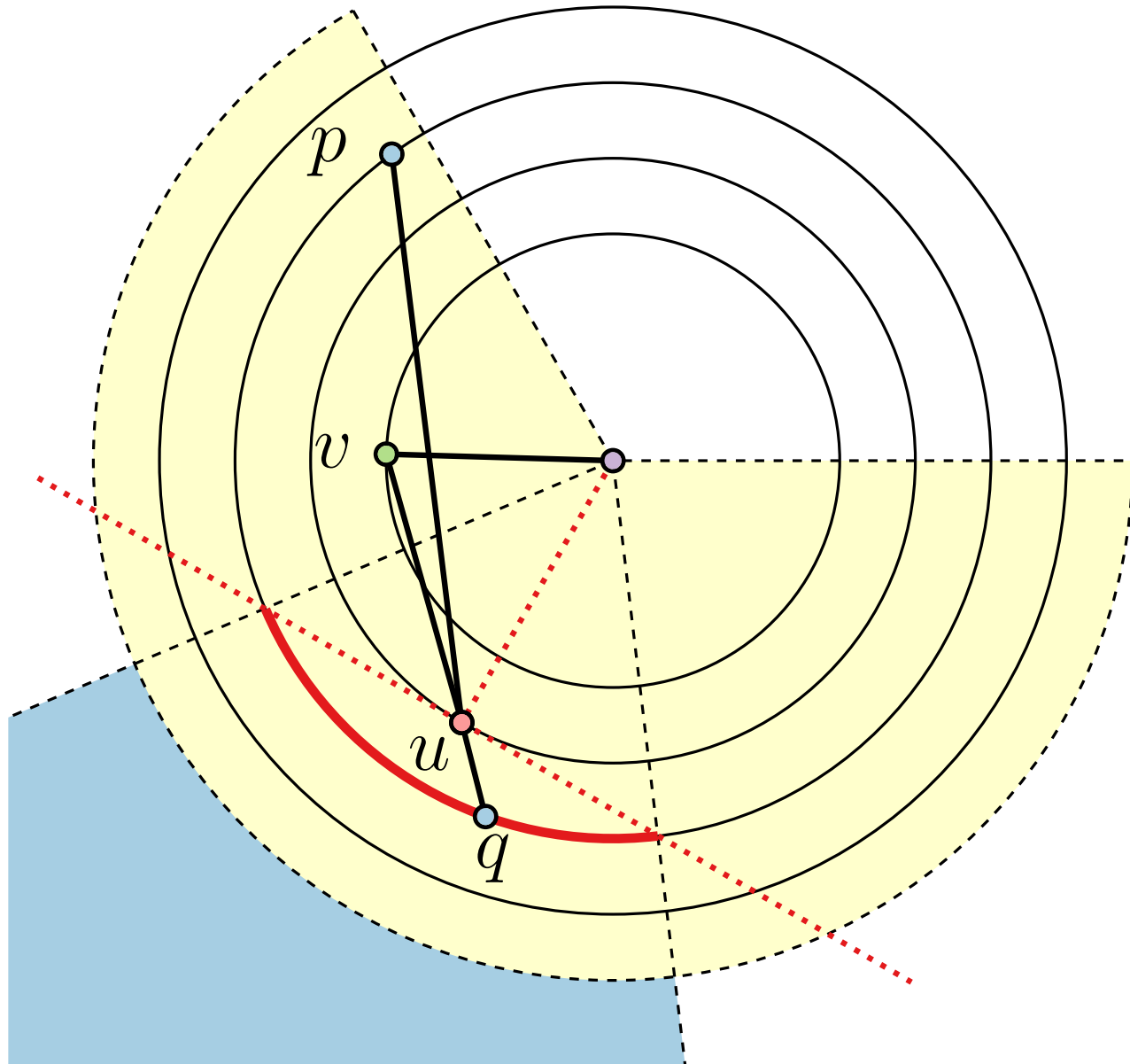

Radial Layouts – How To Avoid Crossings

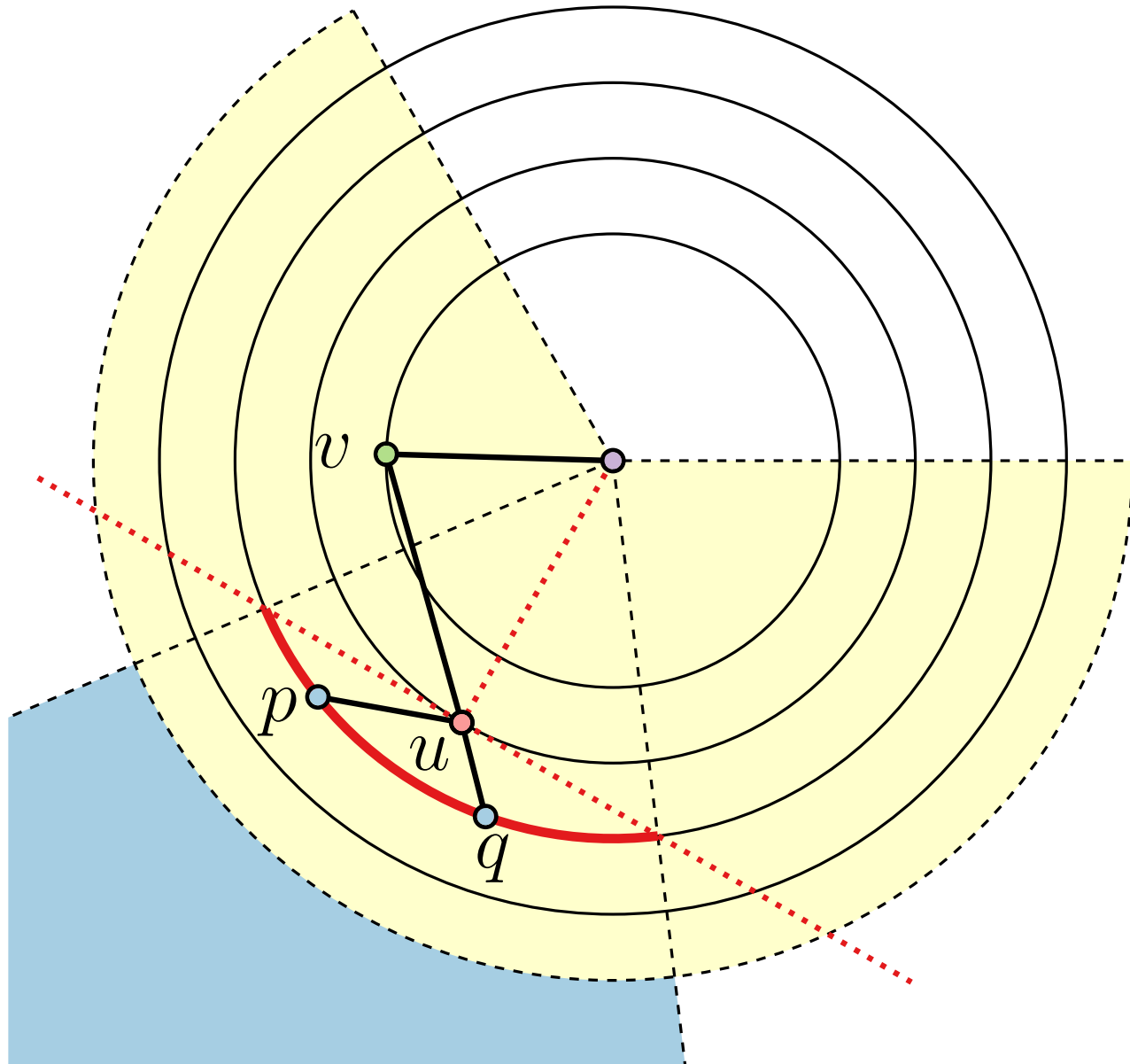

Radial Layouts – How To Avoid Crossings

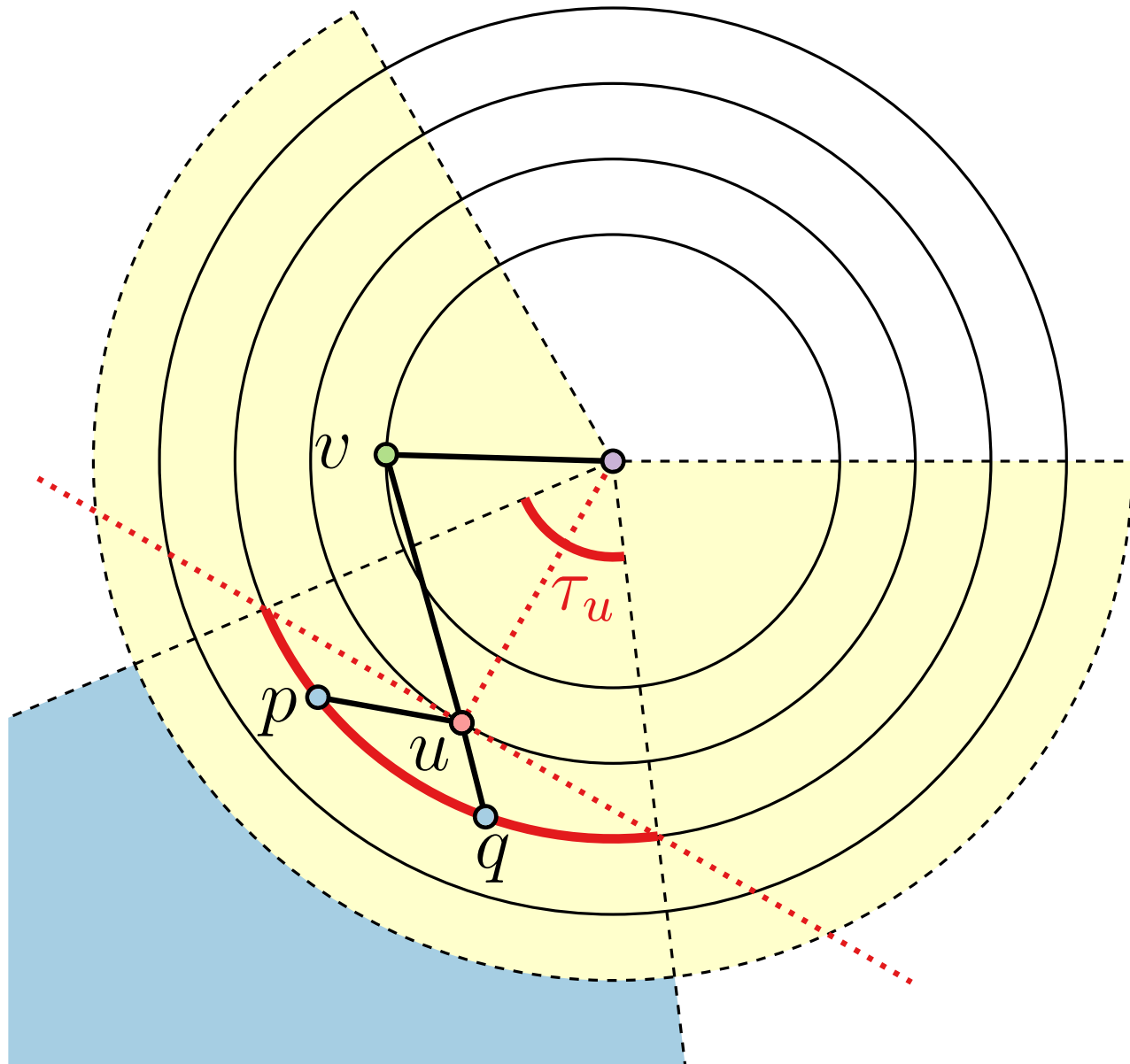

- τ_u – angle of the wedge corresponding to vertex u

Radial Layouts – How To Avoid Crossings

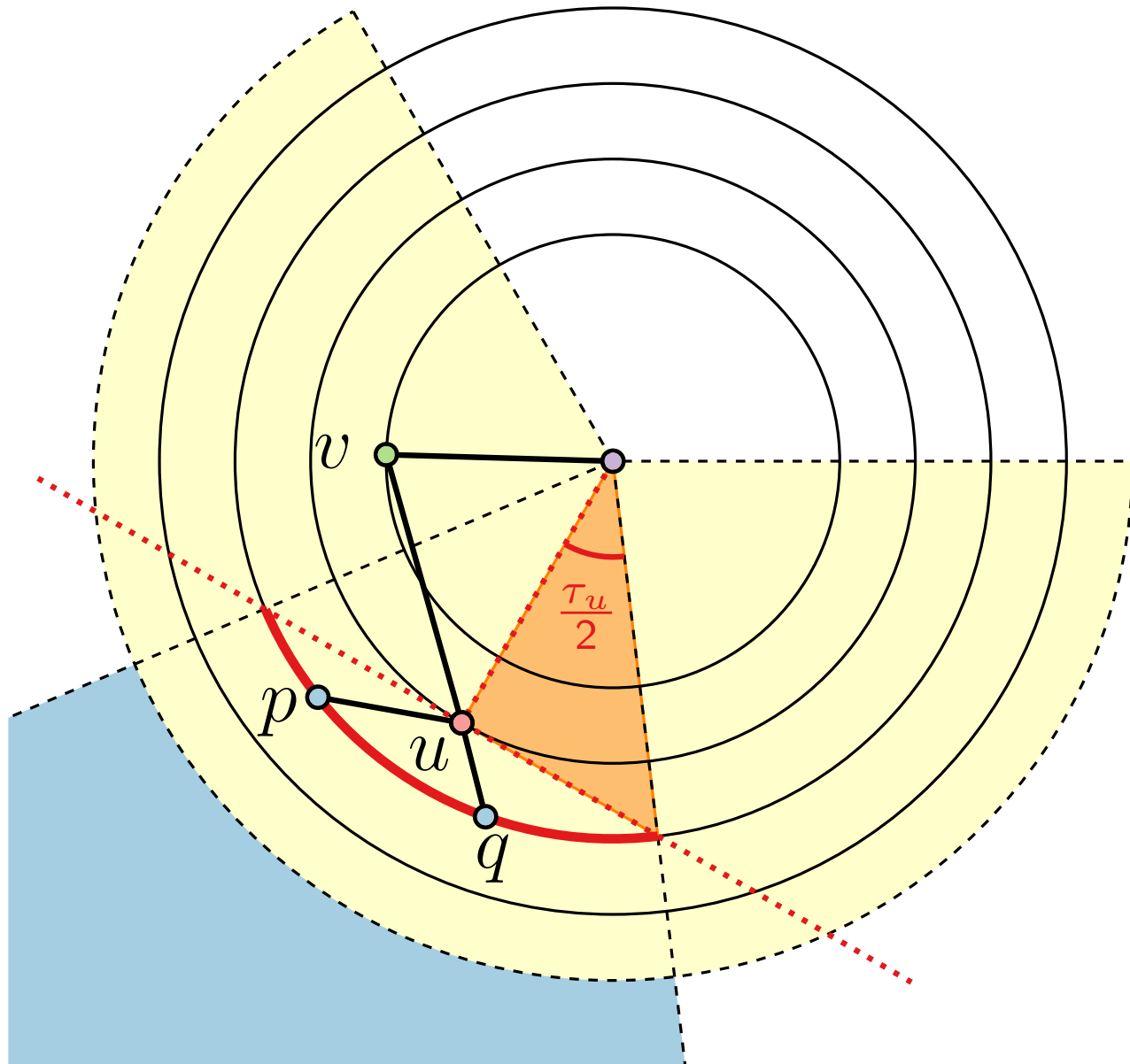

- τ_u – angle of the wedge corresponding to vertex u

Radial Layouts – How To Avoid Crossings

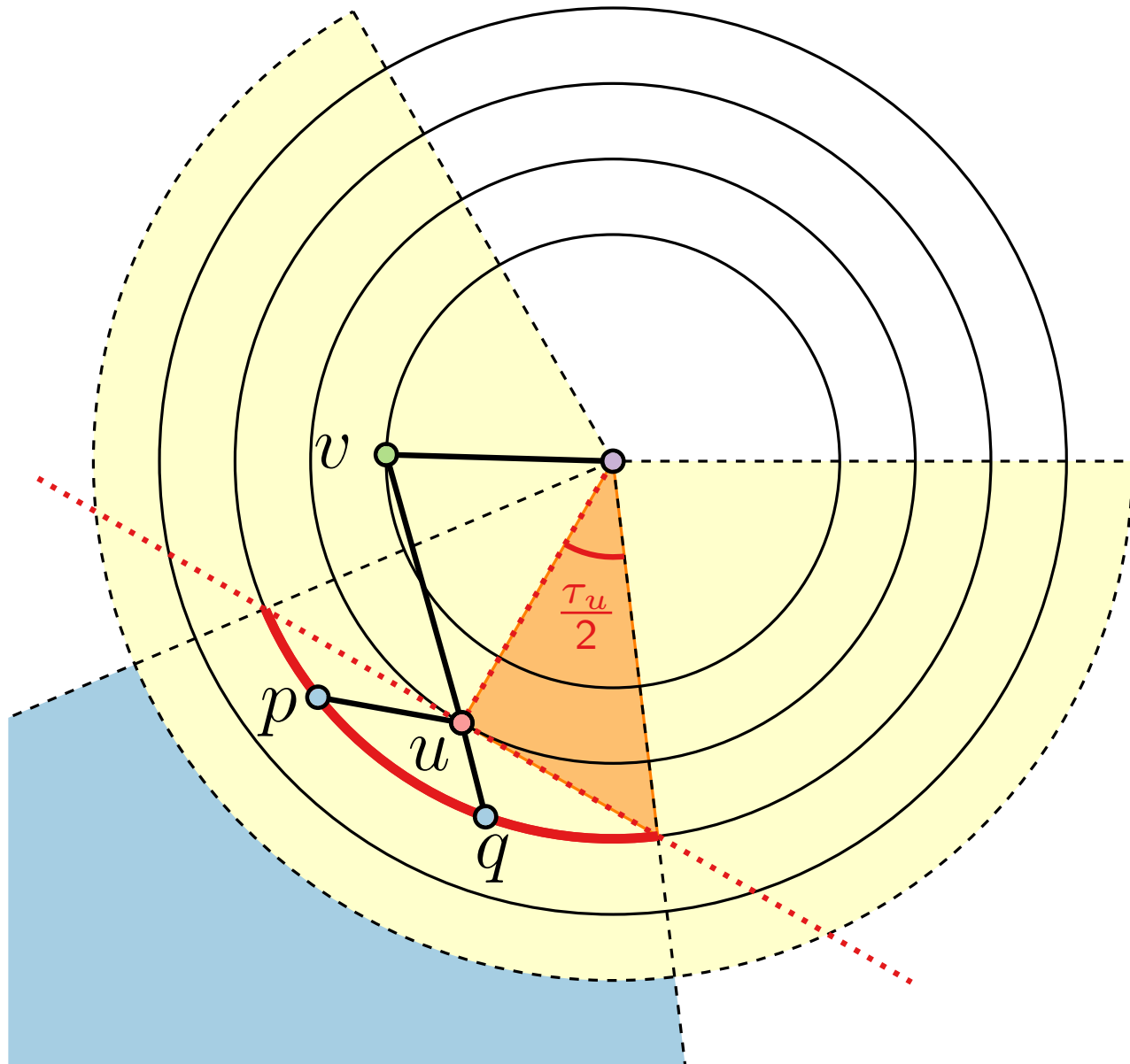

- τ_u – angle of the wedge corresponding to vertex u
- $\ell(u)$ – number of nodes in the subtree rooted at u

Radial Layouts – How To Avoid Crossings

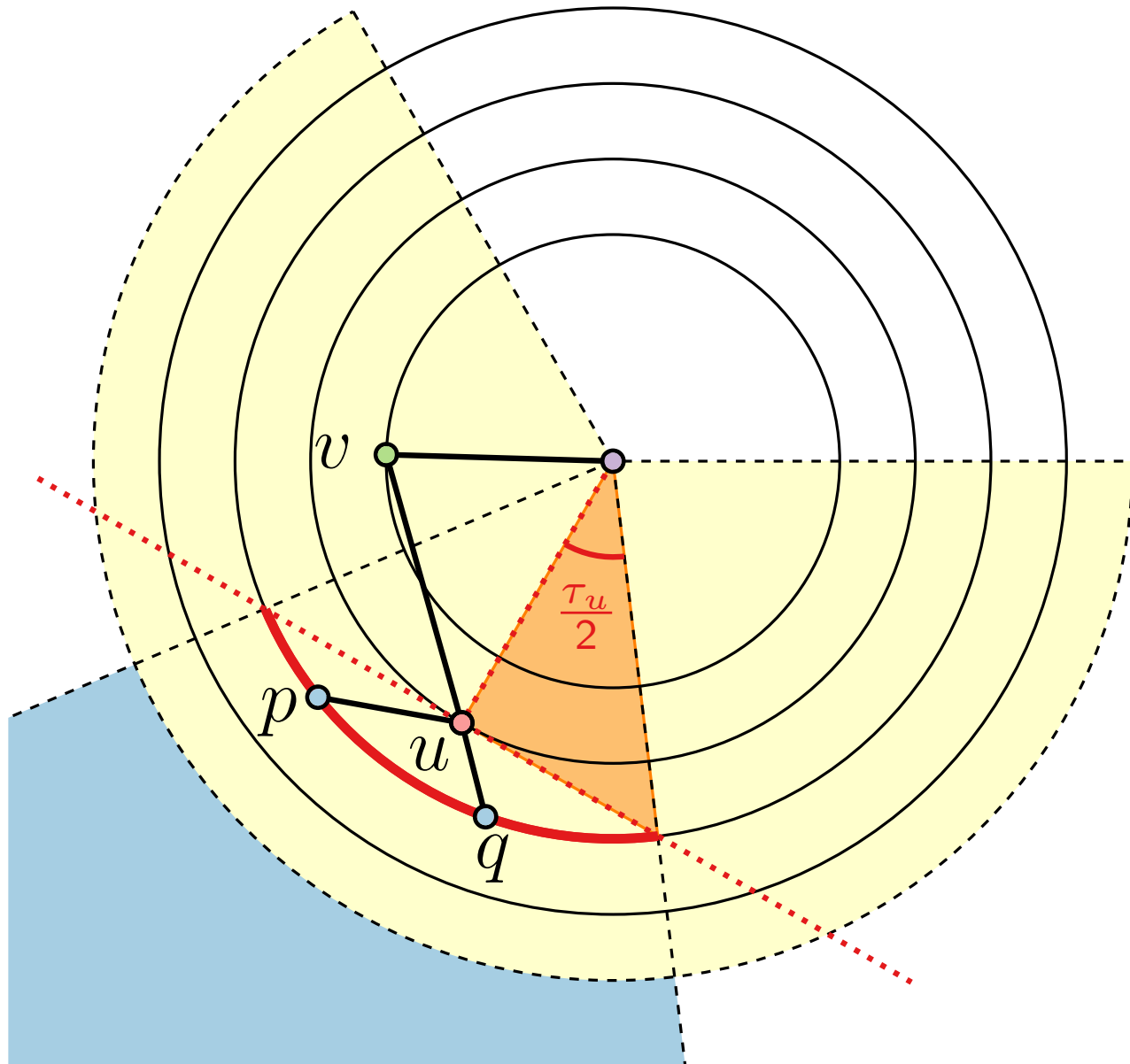

- τ_u – angle of the wedge corresponding to vertex u
- $\ell(u)$ – number of nodes in the subtree rooted at u
- ρ_i – radius of layer i

Radial Layouts – How To Avoid Crossings

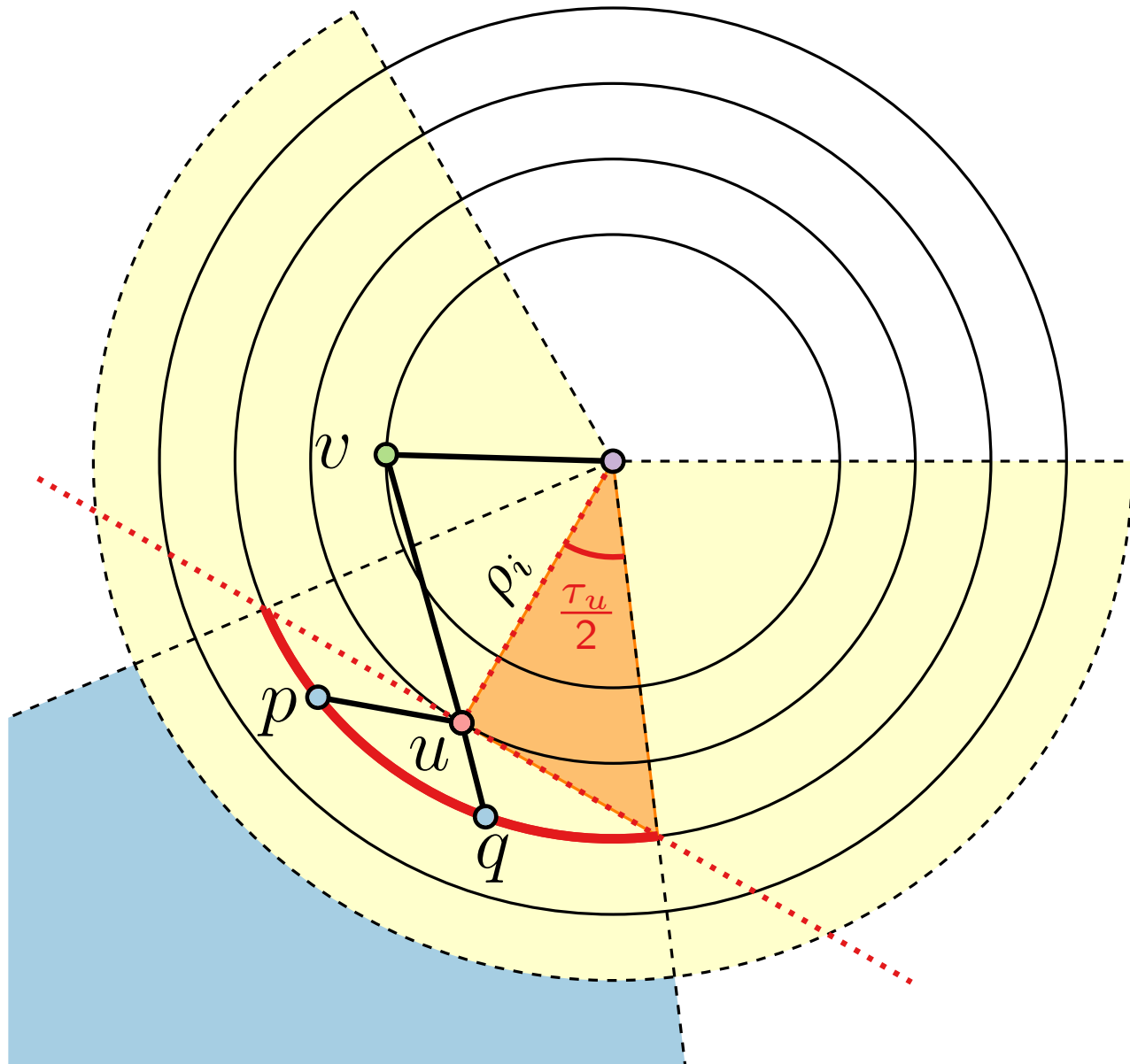

- τ_u – angle of the wedge corresponding to vertex u
- $\ell(u)$ – number of nodes in the subtree rooted at u
- ρ_i – radius of layer i

Radial Layouts – How To Avoid Crossings

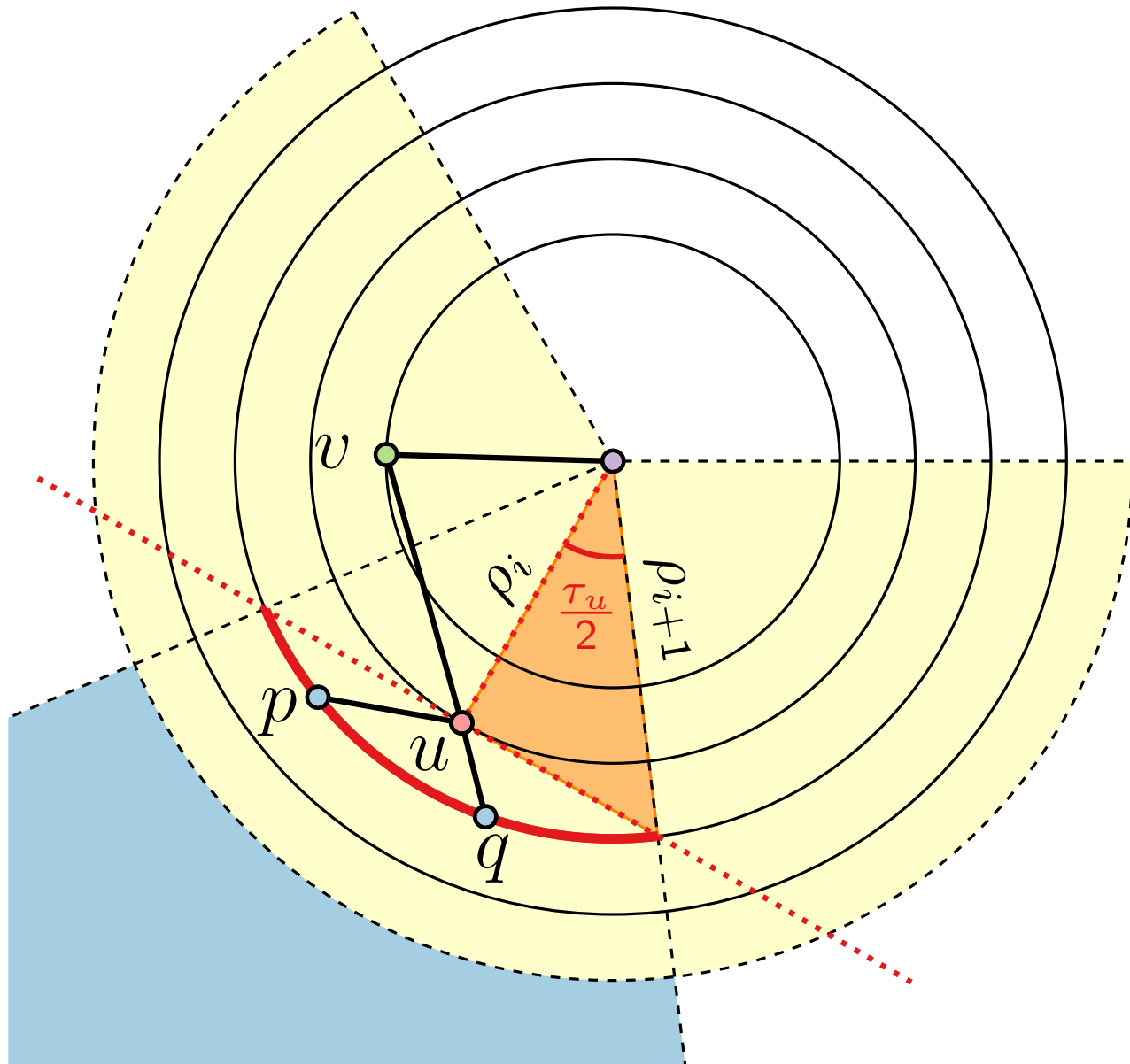

- τ_u – angle of the wedge corresponding to vertex u
- $\ell(u)$ – number of nodes in the subtree rooted at u
- ρ_i – radius of layer i

Radial Layouts – How To Avoid Crossings

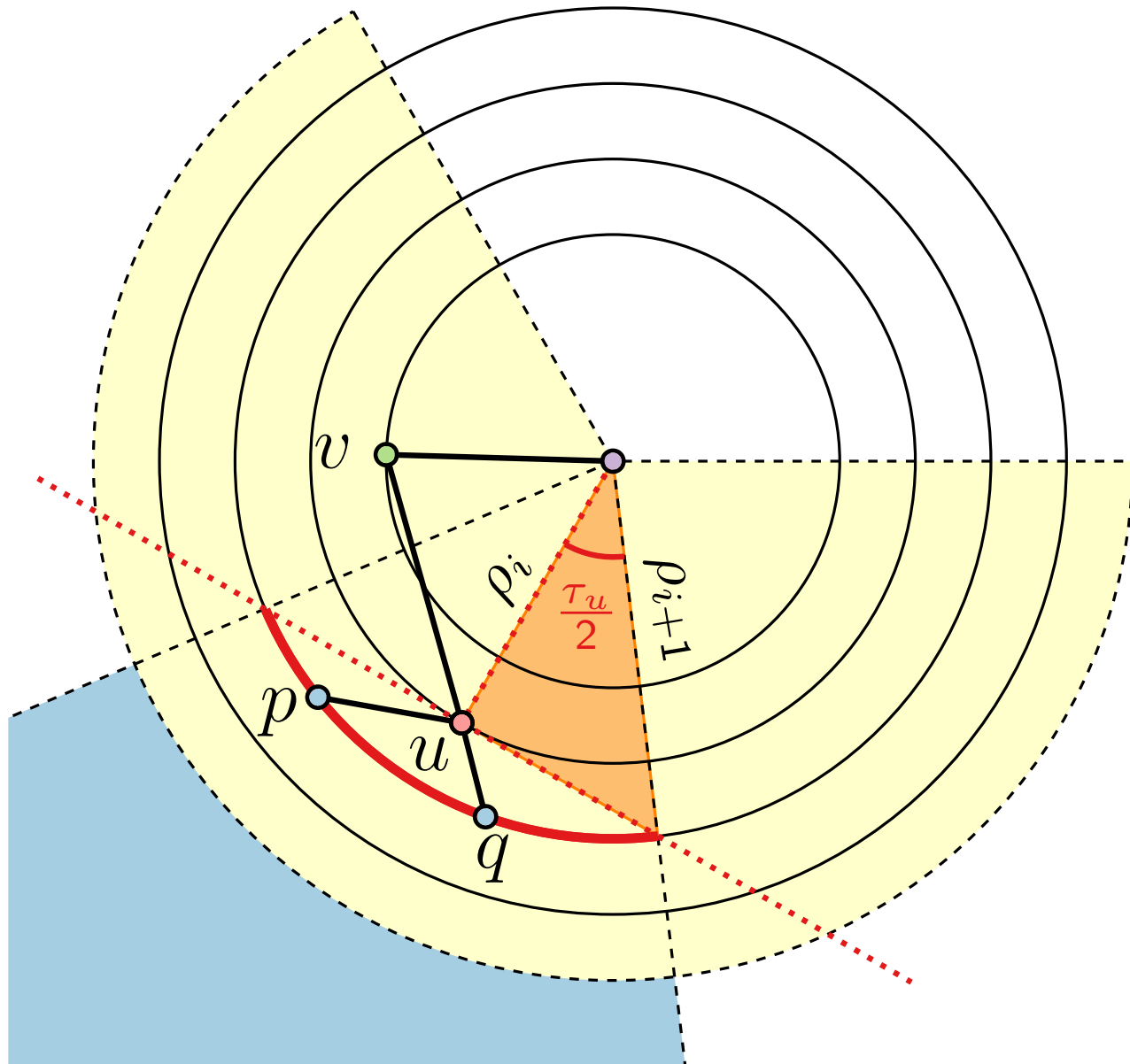

- τ_u – angle of the wedge corresponding to vertex u
- $\ell(u)$ – number of nodes in the subtree rooted at u
- ρ_i – radius of layer i
- $\cos(\tau_u/2) = \rho_i/\rho_{i+1}$

Radial Layouts – How To Avoid Crossings

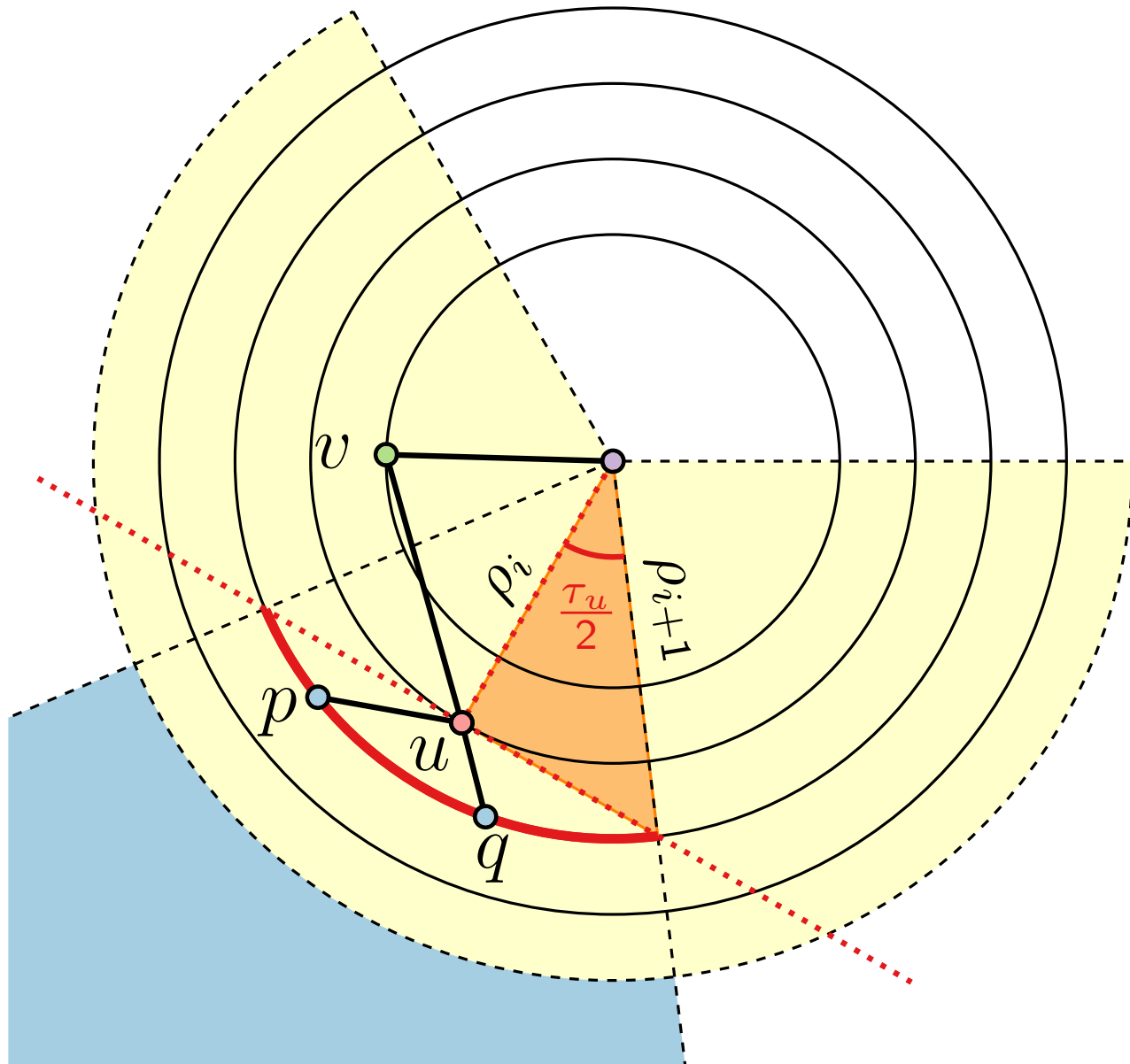

- τ_u – angle of the wedge corresponding to vertex u
- $\ell(u)$ – number of nodes in the subtree rooted at u
- ρ_i – radius of layer i
- $\cos(\tau_u/2) = \rho_i/\rho_{i+1}$
- $\tau_u = \min \left\{ \frac{\ell(u)}{\ell(v)-1} \cdot \tau_v, 2 \arccos \frac{\rho_i}{\rho_{i+1}} \right\}$

Radial Layouts – How To Avoid Crossings

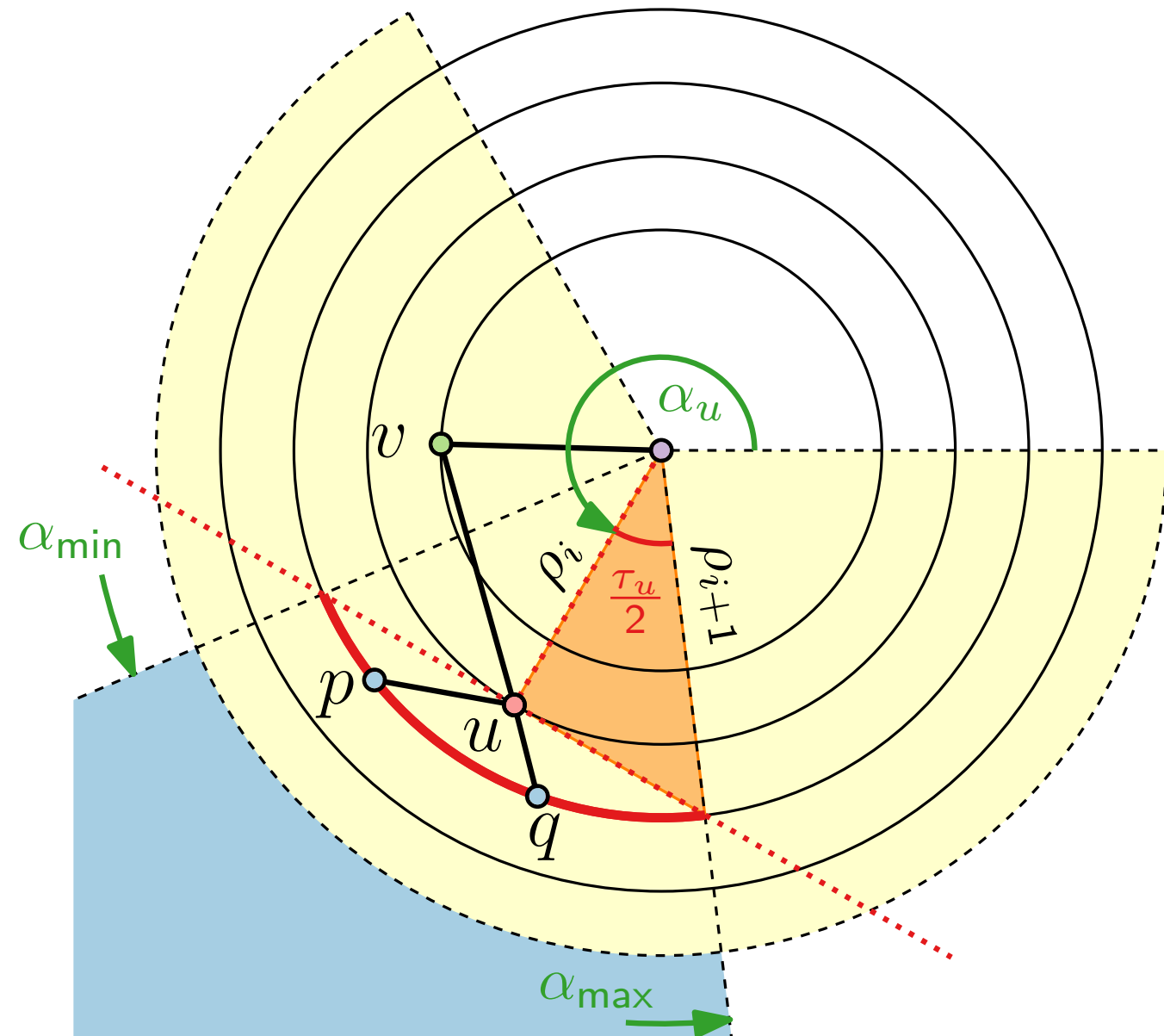

- τ_u – angle of the wedge corresponding to vertex u
- $\ell(u)$ – number of nodes in the subtree rooted at u
- ρ_i – radius of layer i
- $\cos(\tau_u/2) = \rho_i/\rho_{i+1}$
- $\tau_u = \min \left\{ \frac{\ell(u)}{\ell(v)-1} \cdot \tau_v, 2 \arccos \frac{\rho_i}{\rho_{i+1}} \right\}$
- Alternative:
 - $\alpha_{\min} = \alpha_u - \arccos \frac{\rho_i}{\rho_{i+1}}$
 - $\alpha_{\max} = \alpha_u + \arccos \frac{\rho_i}{\rho_{i+1}}$

Radial Layouts – Pseudocode

```
RadialTreeLayout(tree  $T$ , root  $r \in T$ , radii  $\rho_1 < \dots < \rho_k$ )  
┌  
│ postorder( $r$ )  
│ preorder( $r$ , 0, 0,  $2\pi$ )  
│ return  $(d_v, \alpha_v)_{v \in V(T)}$   
└ // vertex positions in polar coordinates
```

Radial Layouts – Pseudocode

```
RadialTreeLayout(tree  $T$ , root  $r \in T$ , radii  $\rho_1 < \dots < \rho_k$ )
```

```
  postorder( $r$ )
```

```
  preorder( $r$ , 0, 0,  $2\pi$ )
```

```
  return  $(d_v, \alpha_v)_{v \in V(T)}$ 
```

```
  // vertex positions in polar coordinates
```

```
postorder(vertex  $v$ )
```

```
   $\ell(v) \leftarrow 1$ 
```

```
  foreach child  $w$  of  $v$  do
```

```
    compute the size of  
    the subtree recursively.
```

Radial Layouts – Pseudocode

```
RadialTreeLayout(tree  $T$ , root  $r \in T$ , radii  $\rho_1 < \dots < \rho_k$ )
```

```
  postorder( $r$ )
```

```
  preorder( $r$ , 0, 0,  $2\pi$ )
```

```
  return  $(d_v, \alpha_v)_{v \in V(T)}$ 
```

```
  // vertex positions in polar coordinates
```

```
postorder(vertex  $v$ )
```

```
   $\ell(v) \leftarrow 1$ 
```

```
  foreach child  $w$  of  $v$  do
```

```
    postorder( $w$ )
```

```
     $\ell(v) \leftarrow \ell(v) + \ell(w)$ 
```

Radial Layouts – Pseudocode

```
RadialTreeLayout(tree  $T$ , root  $r \in T$ , radii  $\rho_1 < \dots < \rho_k$ )
```

```
  postorder( $r$ )
```

```
  preorder( $r$ , 0, 0,  $2\pi$ )
```

```
  return  $(d_v, \alpha_v)_{v \in V(T)}$ 
```

```
  // vertex positions in polar coordinates
```

```
postorder(vertex  $v$ )
```

```
   $\ell(v) \leftarrow 1$ 
```

```
  foreach child  $w$  of  $v$  do
```

```
    postorder( $w$ )
```

```
     $\ell(v) \leftarrow \ell(v) + \ell(w)$ 
```

```
preorder(vertex  $v$ ,  $t$ ,  $\alpha_{\min}$ ,  $\alpha_{\max}$ )
```

Radial Layouts – Pseudocode

```
RadialTreeLayout(tree  $T$ , root  $r \in T$ , radii  $\rho_1 < \dots < \rho_k$ )
┌ postorder( $r$ )
┌ preorder( $r$ , 0, 0,  $2\pi$ )
┌ return  $(d_v, \alpha_v)_{v \in V(T)}$ 
└ // vertex positions in polar coordinates
```

```
postorder(vertex  $v$ )
┌  $\ell(v) \leftarrow 1$ 
┌ foreach child  $w$  of  $v$  do
└ ┌ postorder( $w$ )
└ └  $\ell(v) \leftarrow \ell(v) + \ell(w)$ 
```

```
preorder(vertex  $v$ ,  $t$ ,  $\alpha_{\min}$ ,  $\alpha_{\max}$ )
┌  $d_v \leftarrow \max\{0, \rho_t\}$ 
```

Radial Layouts – Pseudocode

```
RadialTreeLayout(tree  $T$ , root  $r \in T$ , radii  $\rho_1 < \dots < \rho_k$ )
┌ postorder( $r$ )
┌ preorder( $r$ , 0, 0,  $2\pi$ )
┌ return  $(d_v, \alpha_v)_{v \in V(T)}$ 
└ // vertex positions in polar coordinates
```

```
postorder(vertex  $v$ )
┌  $\ell(v) \leftarrow 1$ 
┌ foreach child  $w$  of  $v$  do
└ ┌ postorder( $w$ )
└ └  $\ell(v) \leftarrow \ell(v) + \ell(w)$ 
```

```
preorder(vertex  $v$ ,  $t$ ,  $\alpha_{\min}$ ,  $\alpha_{\max}$ )
┌  $d_v \leftarrow \max\{0, \rho_t\}$ 
└  $\alpha_v \leftarrow (\alpha_{\min} + \alpha_{\max})/2$ 
```

Radial Layouts – Pseudocode

```
RadialTreeLayout(tree  $T$ , root  $r \in T$ , radii  $\rho_1 < \dots < \rho_k$ )
┌ postorder( $r$ )
┌ preorder( $r$ , 0, 0,  $2\pi$ )
┌ return  $(d_v, \alpha_v)_{v \in V(T)}$ 
┌ // vertex positions in polar coordinates
```

```
postorder(vertex  $v$ )
┌  $\ell(v) \leftarrow 1$ 
┌ foreach child  $w$  of  $v$  do
┌ ┌ postorder( $w$ )
┌ ┌  $\ell(v) \leftarrow \ell(v) + \ell(w)$ 
```

```
preorder(vertex  $v$ ,  $t$ ,  $\alpha_{\min}$ ,  $\alpha_{\max}$ )
```

```
 $d_v \leftarrow \max\{0, \rho_t\}$ 
```

```
 $\alpha_v \leftarrow (\alpha_{\min} + \alpha_{\max})/2$ 
```

Radial Layouts – Pseudocode

```
RadialTreeLayout(tree  $T$ , root  $r \in T$ , radii  $\rho_1 < \dots < \rho_k$ )
┌
│ postorder( $r$ )
│ preorder( $r$ , 0, 0,  $2\pi$ )
│ return  $(d_v, \alpha_v)_{v \in V(T)}$ 
│ // vertex positions in polar coordinates
```

```
postorder(vertex  $v$ )
┌
│  $\ell(v) \leftarrow 1$ 
│ foreach child  $w$  of  $v$  do
│ ┌
│ │ postorder( $w$ )
│ │  $\ell(v) \leftarrow \ell(v) + \ell(w)$ 
```

```
preorder(vertex  $v$ ,  $t$ ,  $\alpha_{\min}$ ,  $\alpha_{\max}$ )
┌
│  $d_v \leftarrow \max\{0, \rho_t\}$  // output
│  $\alpha_v \leftarrow (\alpha_{\min} + \alpha_{\max})/2$ 
```

Radial Layouts – Pseudocode

```
RadialTreeLayout(tree  $T$ , root  $r \in T$ , radii  $\rho_1 < \dots < \rho_k$ )
┌ postorder( $r$ )
┌ preorder( $r$ , 0, 0,  $2\pi$ )
└ return  $(d_v, \alpha_v)_{v \in V(T)}$ 
  // vertex positions in polar coordinates
```

```
postorder(vertex  $v$ )
┌  $\ell(v) \leftarrow 1$ 
┌ foreach child  $w$  of  $v$  do
┌   postorder( $w$ )
└    $\ell(v) \leftarrow \ell(v) + \ell(w)$ 
```

```
preorder(vertex  $v$ ,  $t$ ,  $\alpha_{\min}$ ,  $\alpha_{\max}$ )
┌  $d_v \leftarrow \max\{0, \rho_t\}$  // output
┌  $\alpha_v \leftarrow (\alpha_{\min} + \alpha_{\max})/2$ 
└ if  $t > 0$  then
└   ┌
```

Radial Layouts – Pseudocode

RadialTreeLayout(tree T , root $r \in T$, radii $\rho_1 < \dots < \rho_k$)

```

postorder( $r$ )
preorder( $r$ , 0, 0,  $2\pi$ )
return  $(d_v, \alpha_v)_{v \in V(T)}$ 
// vertex positions in polar coordinates

```

postorder(vertex v)

```

 $l(v) \leftarrow 1$ 
foreach child  $w$  of  $v$  do
    postorder( $w$ )
     $l(v) \leftarrow l(v) + l(w)$ 

```

preorder(vertex v , t , α_{\min} , α_{\max})

```

 $d_v \leftarrow \max\{0, \rho_t\}$  // output
 $\alpha_v \leftarrow (\alpha_{\min} + \alpha_{\max})/2$ 
if  $t > 0$  then
     $\alpha_{\min} \leftarrow \max\{\alpha_{\min}, \alpha_v - \arccos \frac{\rho_t}{\rho_{t+1}}\}$ 
     $\alpha_{\max} \leftarrow \min\{\alpha_{\max}, \alpha_v + \arccos \frac{\rho_t}{\rho_{t+1}}\}$ 

```

Radial Layouts – Pseudocode

RadialTreeLayout(tree T , root $r \in T$, radii $\rho_1 < \dots < \rho_k$)

```

postorder( $r$ )
preorder( $r$ , 0, 0,  $2\pi$ )
return  $(d_v, \alpha_v)_{v \in V(T)}$ 
// vertex positions in polar coordinates

```

postorder(vertex v)

```

 $\ell(v) \leftarrow 1$ 
foreach child  $w$  of  $v$  do
    postorder( $w$ )
     $\ell(v) \leftarrow \ell(v) + \ell(w)$ 

```

preorder(vertex v , t , α_{\min} , α_{\max})

```

 $d_v \leftarrow \max\{0, \rho_t\}$  // output
 $\alpha_v \leftarrow (\alpha_{\min} + \alpha_{\max})/2$ 
if  $t > 0$  then
     $\alpha_{\min} \leftarrow \max\{\alpha_{\min}, \alpha_v - \arccos \frac{\rho_t}{\rho_{t+1}}\}$ 
     $\alpha_{\max} \leftarrow \min\{\alpha_{\max}, \alpha_v + \arccos \frac{\rho_t}{\rho_{t+1}}\}$ 
     $left \leftarrow \alpha_{\min}$ 

```

Radial Layouts – Pseudocode

RadialTreeLayout(tree T , root $r \in T$, radii $\rho_1 < \dots < \rho_k$)

```

postorder( $r$ )
preorder( $r$ , 0, 0,  $2\pi$ )
return  $(d_v, \alpha_v)_{v \in V(T)}$ 
// vertex positions in polar coordinates

```

postorder(vertex v)

```

 $\ell(v) \leftarrow 1$ 
foreach child  $w$  of  $v$  do
    postorder( $w$ )
     $\ell(v) \leftarrow \ell(v) + \ell(w)$ 

```

preorder(vertex v , t , α_{\min} , α_{\max})

```

 $d_v \leftarrow \max\{0, \rho_t\}$  // output
 $\alpha_v \leftarrow (\alpha_{\min} + \alpha_{\max})/2$ 
if  $t > 0$  then
     $\alpha_{\min} \leftarrow \max\{\alpha_{\min}, \alpha_v - \arccos \frac{\rho_t}{\rho_{t+1}}\}$ 
     $\alpha_{\max} \leftarrow \min\{\alpha_{\max}, \alpha_v + \arccos \frac{\rho_t}{\rho_{t+1}}\}$ 
     $left \leftarrow \alpha_{\min}$ 
    foreach child  $w$  of  $v$  do

```

Radial Layouts – Pseudocode

RadialTreeLayout(tree T , root $r \in T$, radii $\rho_1 < \dots < \rho_k$)

```

postorder( $r$ )
preorder( $r$ , 0, 0,  $2\pi$ )
return  $(d_v, \alpha_v)_{v \in V(T)}$ 
// vertex positions in polar coordinates

```

postorder(vertex v)

```

 $l(v) \leftarrow 1$ 
foreach child  $w$  of  $v$  do
    postorder( $w$ )
     $l(v) \leftarrow l(v) + l(w)$ 

```

preorder(vertex v , t , α_{\min} , α_{\max})

```

 $d_v \leftarrow \max\{0, \rho_t\}$  // output
 $\alpha_v \leftarrow (\alpha_{\min} + \alpha_{\max})/2$ 
if  $t > 0$  then
     $\alpha_{\min} \leftarrow \max\{\alpha_{\min}, \alpha_v - \arccos \frac{\rho_t}{\rho_{t+1}}\}$ 
     $\alpha_{\max} \leftarrow \min\{\alpha_{\max}, \alpha_v + \arccos \frac{\rho_t}{\rho_{t+1}}\}$ 
     $left \leftarrow \alpha_{\min}$ 
    foreach child  $w$  of  $v$  do
         $right \leftarrow left + \frac{l(w)}{l(v)-1} \cdot (\alpha_{\max} - \alpha_{\min})$ 

```

Radial Layouts – Pseudocode

RadialTreeLayout(tree T , root $r \in T$, radii $\rho_1 < \dots < \rho_k$)

```

postorder( $r$ )
preorder( $r$ , 0, 0,  $2\pi$ )
return  $(d_v, \alpha_v)_{v \in V(T)}$ 
// vertex positions in polar coordinates

```

postorder(vertex v)

```

 $\ell(v) \leftarrow 1$ 
foreach child  $w$  of  $v$  do
    postorder( $w$ )
     $\ell(v) \leftarrow \ell(v) + \ell(w)$ 

```

preorder(vertex v , t , α_{\min} , α_{\max})

```

 $d_v \leftarrow \max\{0, \rho_t\}$  // output
 $\alpha_v \leftarrow (\alpha_{\min} + \alpha_{\max})/2$ 
if  $t > 0$  then
     $\alpha_{\min} \leftarrow \max\{\alpha_{\min}, \alpha_v - \arccos \frac{\rho_t}{\rho_{t+1}}\}$ 
     $\alpha_{\max} \leftarrow \min\{\alpha_{\max}, \alpha_v + \arccos \frac{\rho_t}{\rho_{t+1}}\}$ 
     $left \leftarrow \alpha_{\min}$ 
    foreach child  $w$  of  $v$  do
         $right \leftarrow left + \frac{\ell(w)}{\ell(v)-1} \cdot (\alpha_{\max} - \alpha_{\min})$ 
        preorder( $w$ ,  $t + 1$ ,  $left$ ,  $right$ )

```

Radial Layouts – Pseudocode

RadialTreeLayout(tree T , root $r \in T$, radii $\rho_1 < \dots < \rho_k$)

```

postorder( $r$ )
preorder( $r$ , 0, 0,  $2\pi$ )
return  $(d_v, \alpha_v)_{v \in V(T)}$ 
// vertex positions in polar coordinates

```

postorder(vertex v)

```

 $\ell(v) \leftarrow 1$ 
foreach child  $w$  of  $v$  do
    postorder( $w$ )
     $\ell(v) \leftarrow \ell(v) + \ell(w)$ 

```

preorder(vertex v , t , α_{\min} , α_{\max})

```

 $d_v \leftarrow \max\{0, \rho_t\}$  // output
 $\alpha_v \leftarrow (\alpha_{\min} + \alpha_{\max})/2$ 
if  $t > 0$  then
     $\alpha_{\min} \leftarrow \max\{\alpha_{\min}, \alpha_v - \arccos \frac{\rho_t}{\rho_{t+1}}\}$ 
     $\alpha_{\max} \leftarrow \min\{\alpha_{\max}, \alpha_v + \arccos \frac{\rho_t}{\rho_{t+1}}\}$ 
     $left \leftarrow \alpha_{\min}$ 
    foreach child  $w$  of  $v$  do
         $right \leftarrow left + \frac{\ell(w)}{\ell(v)-1} \cdot (\alpha_{\max} - \alpha_{\min})$ 
        preorder( $w$ ,  $t + 1$ ,  $left$ ,  $right$ )
         $left \leftarrow right$ 

```

Radial Layouts – Pseudocode

RadialTreeLayout(tree T , root $r \in T$, radii $\rho_1 < \dots < \rho_k$)

```

postorder( $r$ )
preorder( $r$ , 0, 0,  $2\pi$ )
return  $(d_v, \alpha_v)_{v \in V(T)}$ 
// vertex positions in polar coordinates

```

postorder(vertex v)

```

 $\ell(v) \leftarrow 1$ 
foreach child  $w$  of  $v$  do
    postorder( $w$ )
     $\ell(v) \leftarrow \ell(v) + \ell(w)$ 

```

preorder(vertex v , t , α_{\min} , α_{\max})

```

 $d_v \leftarrow \max\{0, \rho_t\}$  // output
 $\alpha_v \leftarrow (\alpha_{\min} + \alpha_{\max})/2$ 
if  $t > 0$  then
     $\alpha_{\min} \leftarrow \max\{\alpha_{\min}, \alpha_v - \arccos \frac{\rho_t}{\rho_{t+1}}\}$ 
     $\alpha_{\max} \leftarrow \min\{\alpha_{\max}, \alpha_v + \arccos \frac{\rho_t}{\rho_{t+1}}\}$ 
     $left \leftarrow \alpha_{\min}$ 
    foreach child  $w$  of  $v$  do
         $right \leftarrow left + \frac{\ell(w)}{\ell(v)-1} \cdot (\alpha_{\max} - \alpha_{\min})$ 
        preorder( $w$ ,  $t + 1$ ,  $left$ ,  $right$ )
         $left \leftarrow right$ 

```

Runtime?

Radial Layouts – Pseudocode

RadialTreeLayout(tree T , root $r \in T$, radii $\rho_1 < \dots < \rho_k$)

```

postorder( $r$ )
preorder( $r$ , 0, 0,  $2\pi$ )
return  $(d_v, \alpha_v)_{v \in V(T)}$ 
// vertex positions in polar coordinates

```

postorder(vertex v)

```

 $\ell(v) \leftarrow 1$ 
foreach child  $w$  of  $v$  do
    postorder( $w$ )
     $\ell(v) \leftarrow \ell(v) + \ell(w)$ 

```

Runtime? $\mathcal{O}(n)$

preorder(vertex v , t , α_{\min} , α_{\max})

```

 $d_v \leftarrow \max\{0, \rho_t\}$  // output
 $\alpha_v \leftarrow (\alpha_{\min} + \alpha_{\max})/2$ 
if  $t > 0$  then
     $\alpha_{\min} \leftarrow \max\{\alpha_{\min}, \alpha_v - \arccos \frac{\rho_t}{\rho_{t+1}}\}$ 
     $\alpha_{\max} \leftarrow \min\{\alpha_{\max}, \alpha_v + \arccos \frac{\rho_t}{\rho_{t+1}}\}$ 
     $left \leftarrow \alpha_{\min}$ 
    foreach child  $w$  of  $v$  do
         $right \leftarrow left + \frac{\ell(w)}{\ell(v)-1} \cdot (\alpha_{\max} - \alpha_{\min})$ 
        preorder( $w$ ,  $t + 1$ ,  $left$ ,  $right$ )
         $left \leftarrow right$ 

```

Radial Layouts – Pseudocode

RadialTreeLayout(tree T , root $r \in T$, radii $\rho_1 < \dots < \rho_k$)

```

postorder( $r$ )
preorder( $r$ , 0, 0,  $2\pi$ )
return  $(d_v, \alpha_v)_{v \in V(T)}$ 
// vertex positions in polar coordinates

```

postorder(vertex v)

```

 $\ell(v) \leftarrow 1$ 
foreach child  $w$  of  $v$  do
    postorder( $w$ )
     $\ell(v) \leftarrow \ell(v) + \ell(w)$ 

```

Runtime? $\mathcal{O}(n)$

Correctness?

preorder(vertex v , t , α_{\min} , α_{\max})

```

 $d_v \leftarrow \max\{0, \rho_t\}$  // output
 $\alpha_v \leftarrow (\alpha_{\min} + \alpha_{\max})/2$ 
if  $t > 0$  then
     $\alpha_{\min} \leftarrow \max\{\alpha_{\min}, \alpha_v - \arccos \frac{\rho_t}{\rho_{t+1}}\}$ 
     $\alpha_{\max} \leftarrow \min\{\alpha_{\max}, \alpha_v + \arccos \frac{\rho_t}{\rho_{t+1}}\}$ 
     $left \leftarrow \alpha_{\min}$ 
    foreach child  $w$  of  $v$  do
         $right \leftarrow left + \frac{\ell(w)}{\ell(v)-1} \cdot (\alpha_{\max} - \alpha_{\min})$ 
        preorder( $w$ ,  $t + 1$ ,  $left$ ,  $right$ )
         $left \leftarrow right$ 

```

Radial Layouts – Pseudocode

RadialTreeLayout(tree T , root $r \in T$, radii $\rho_1 < \dots < \rho_k$)

```

postorder( $r$ )
preorder( $r$ , 0, 0,  $2\pi$ )
return  $(d_v, \alpha_v)_{v \in V(T)}$ 
// vertex positions in polar coordinates

```

postorder(vertex v)

```

 $\ell(v) \leftarrow 1$ 
foreach child  $w$  of  $v$  do
    postorder( $w$ )
     $\ell(v) \leftarrow \ell(v) + \ell(w)$ 

```

Runtime? $\mathcal{O}(n)$

Correctness? ✓

preorder(vertex v , t , α_{\min} , α_{\max})

```

 $d_v \leftarrow \max\{0, \rho_t\}$  // output
 $\alpha_v \leftarrow (\alpha_{\min} + \alpha_{\max})/2$ 
if  $t > 0$  then
     $\alpha_{\min} \leftarrow \max\{\alpha_{\min}, \alpha_v - \arccos \frac{\rho_t}{\rho_{t+1}}\}$ 
     $\alpha_{\max} \leftarrow \min\{\alpha_{\max}, \alpha_v + \arccos \frac{\rho_t}{\rho_{t+1}}\}$ 
     $left \leftarrow \alpha_{\min}$ 
    foreach child  $w$  of  $v$  do
         $right \leftarrow left + \frac{\ell(w)}{\ell(v)-1} \cdot (\alpha_{\max} - \alpha_{\min})$ 
        preorder( $w$ ,  $t + 1$ ,  $left$ ,  $right$ )
         $left \leftarrow right$ 

```

Radial Layouts – Result

Theorem.

Let T be a rooted tree with n vertices. The algorithm `RadialTreeLayout` constructs in $O(n)$ time a drawing Γ of T s.t.:

Radial Layouts – Result

Theorem.

Let T be a rooted tree with n vertices. The algorithm `RadialTreeLayout` constructs in $O(n)$ time a drawing Γ of T s.t.:

- Γ is a radial, crossing-free drawing,

Radial Layouts – Result

Theorem.

Let T be a rooted tree with n vertices. The algorithm `RadialTreeLayout` constructs in $O(n)$ time a drawing Γ of T s.t.:

- Γ is a radial, crossing-free drawing,
- vertices lie on circles according to their depth, and

Radial Layouts – Result

Theorem.

Let T be a rooted tree with n vertices. The algorithm `RadialTreeLayout` constructs in $O(n)$ time a drawing Γ of T s.t.:

- Γ is a radial, crossing-free drawing,
- vertices lie on circles according to their depth, and
- the area of Γ is quadratic in $\max\text{-degree}(T) \times \text{height}(T)$ (see [GD Ch. 3.1.3] for the details).

Other Tree Visualization Styles

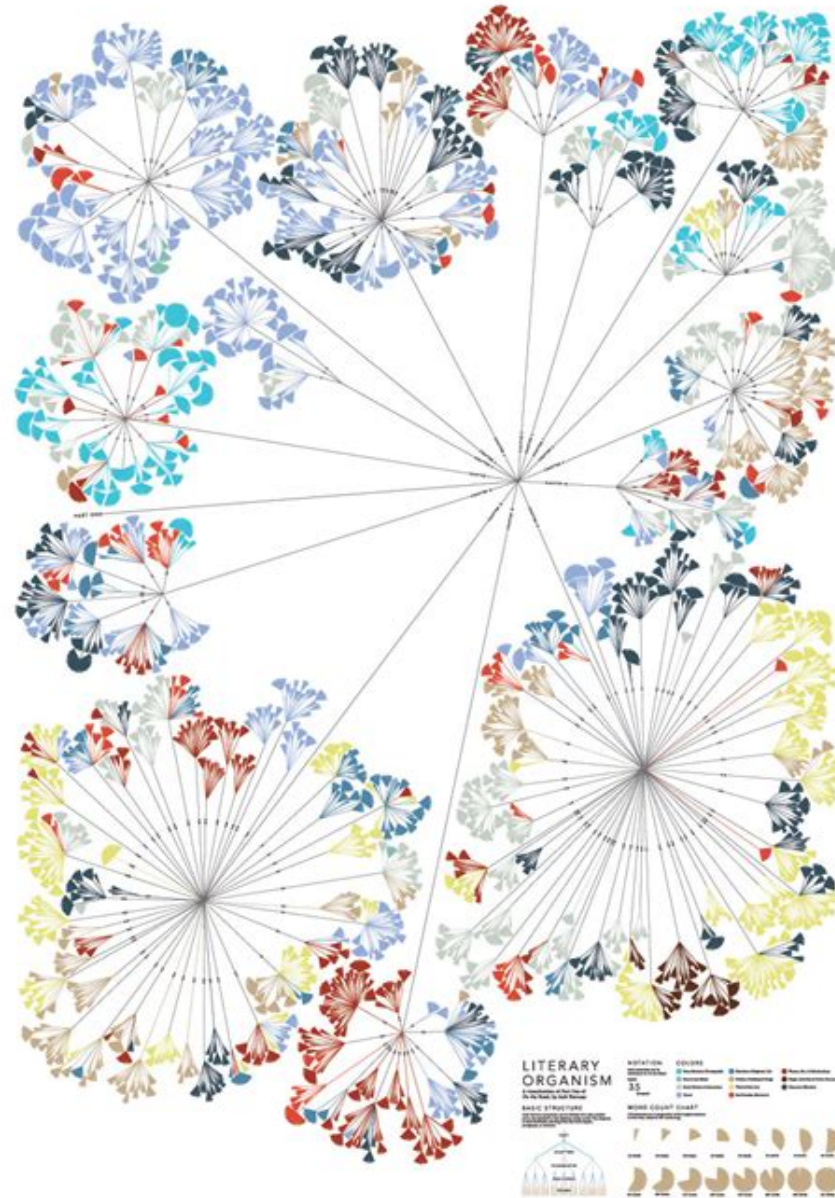

Writing Without Words:
The project explores methods to visualize the differences in writing styles of different authors.

Similar to balloon layout

Other Tree Visualization Styles

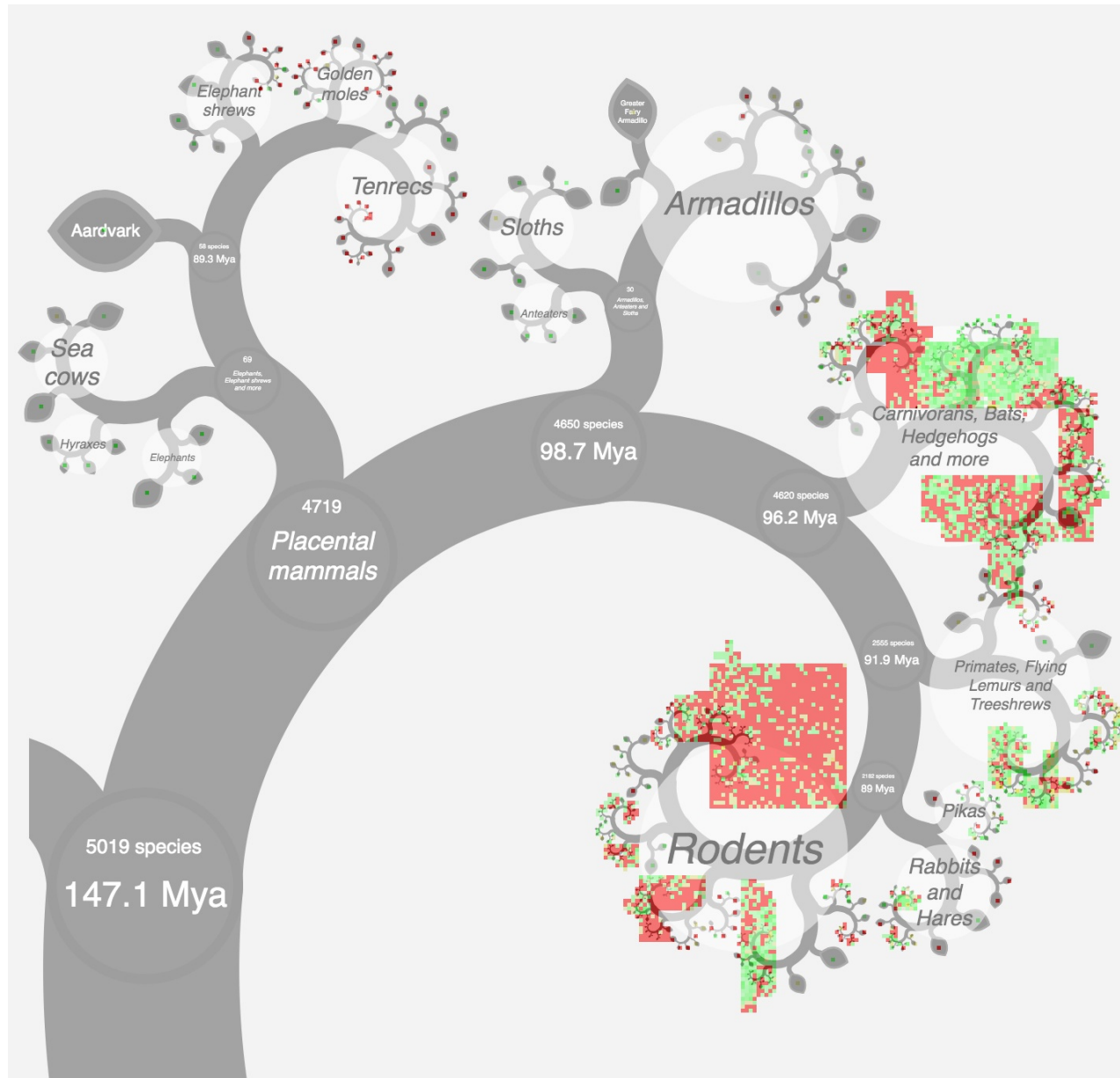

A phylogenetically organized display of data for all placental mammal species.

Fractal layout

Other Tree Visualization Styles

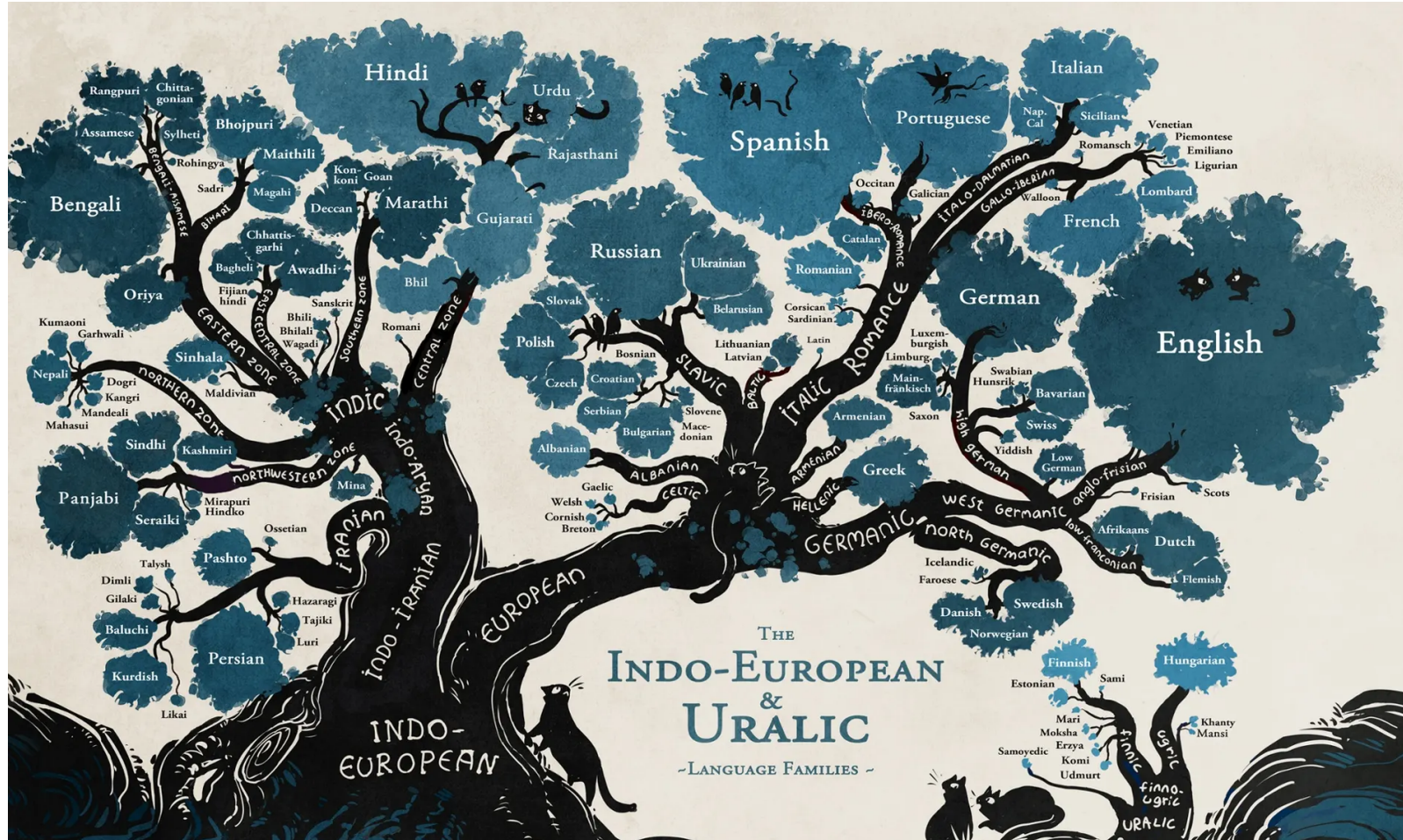

A language family tree – in pictures

Other Tree Visualization Styles

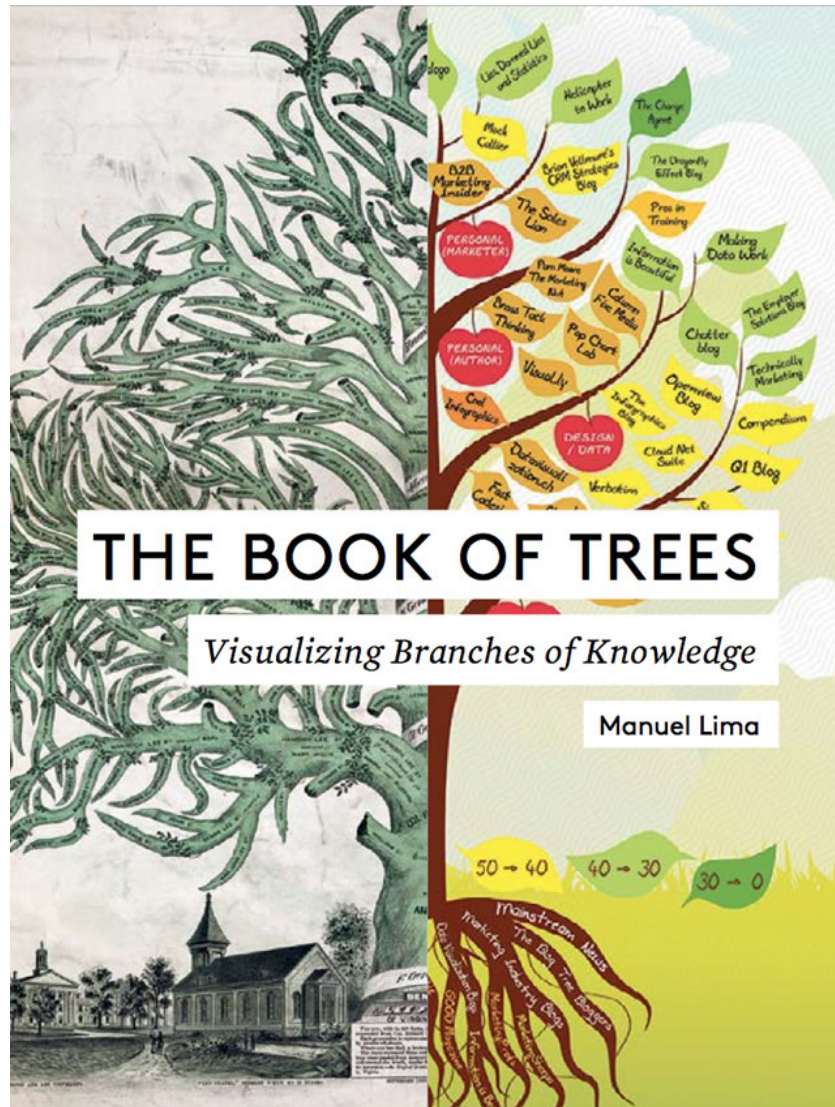

treevis.net

Literature

- [GD, Chapter 3] divide and conquer methods for rooted trees and series-parallel graphs
- [Reingold, Tilford '81] “Tidier Drawings of Trees”
 - original paper for level-based layout algo
- [Reingold, Supowit '83] “The complexity of drawing trees nicely”
 - linear program and NP-hardness proof for area minimization
- `treevis.net` – compendium of drawing methods for trees